



ASSEMBLY INSTRUCTIONS

Pour le français, voir la page 2. 
Para el español, ver la página 3.

20' x 8' OUTDOOR STORAGE SHED

Lifetime sheds are designed to be strong and durable. We strive to make assembly as easy as possible without compromising quality. If you get stuck, we have tools to help:

- **Build a Foundation**
Construct a level surface before you start (see page 6 for instructions).
- **Recruit Friends and Family**
Assembly should take 3 people about 4–6 hours to complete.



For Customer Service in mainland Europe:
E-mail: cs@lifetimeproducts.eu

TOOLS REQUIRED

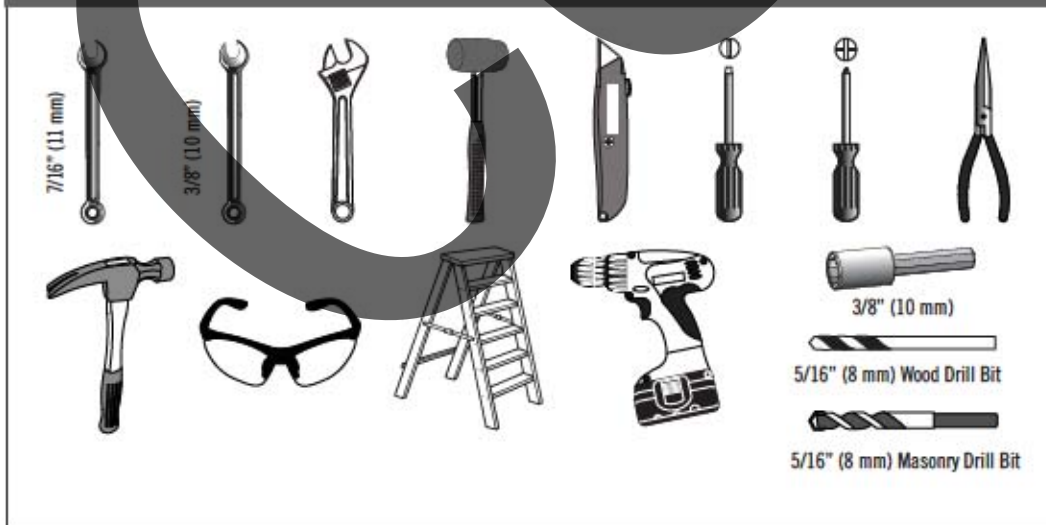

TABLE OF CONTENTS

Icon Legend.....	4
Warnings & Notices.....	5
Platform Construction.....	6
Truss Assembly.....	11
Gable Assembly.....	18
Door Assembly.....	22
Domed Skylight Assembly.....	33
Floor Assembly.....	37
Wall Assembly.....	42
Parts Identifier.....	49
Shelving Installation.....	53
Roof Assembly.....	57
Window Installation.....	79
Shutter Installation.....	81
Accessory Installation.....	84
Snowload Kit Installation.....	86
Door Alignment.....	90
Shed Anchoring.....	92
Cleaning & Care.....	95
Registration.....	96
Warranty.....	97

NEED HELP? TALK TO US!

Lifetime's Assembly Experts offer quick responses and great customer service.

Call: 1-800-225-3865
7:00 am–5:00 pm (Monday–Friday) MST
and 9:00 am–1:00 pm Saturday MST

Web: www.lifetime.com/instructions
Live Chat: www.lifetime.com/instructions

MODEL# AND PRODUCT ID (you will need both when contacting us)
Model Number: Product ID:
60127

LIFETIME

INSTRUCTIONS D'ASSEMBLAGE

For English, see page 1.

Para el español, ver la página 3.



ABRI EXTÉRIEUR DE 6,10 m x 2,44 m

Les abris Lifetime® sont conçus pour être solides et durables. Nous nous efforçons de rendre l'assemblage aussi facile que possible sans compromettre la qualité. Si vous êtes coincé, nous avons les outils nécessaires pour vous aider :

- **Construire une plate-forme**

Construisez une plate-forme nivelée avant de commencer.

(voyez la page 6 pour les instructions)

- **Rassembler vos amis et votre famille**

L'assemblage par 3 adultes devrait prendre à peu près 4 – 6 heures.



Pour les services à la clientèle du continent européen :
É-mail : cs@lifetimeproducts.eu

OUTILS REQUIS (PAS INCLUS)



SOMMAIRE

Légende des icônes.....	4
Avertissements et avis.....	5
Assemblage de la plate-forme.....	6
Assemblage des fermes.....	11
Assemblage des pignons.....	18
Assemblage des portes.....	22
Assemblage des lucarnes.....	33
Assemblage du plancher.....	37
Assemblage des murs.....	42
Identificateur de pièces.....	49
Installation de la estantería.....	53
Assemblage du toit.....	57
Installation des carreaux.....	79
Installation des volets.....	81
Installation des accessoires.....	84
Installation du kit de la charge de neige.....	86
Alignement des portes.....	90
L'ancrage de l'abri.....	92
Nettoyage et entretien.....	95
Enregistrement.....	96
Garantie.....	98

NÉCESSITEZ-VOUS DE L'AIDE ? COMMUNIQUEZ-NOUS !

Composer le 1-800-225-3865

Du lundi au vendredi 7 h – 17 h (HNR)
et samedi 9 h – 13 h (HNR)
(États-Unis et Canada)

web: www.lifetime.com/instructions
tchat: www.lifetime.com/instructions

Nos experts d'assemblage Lifetime® offrent des réponses rapides et un service à la clientèle supérieure.

MODÈLE ET RÉFÉRENCE DU PRODUIT (vous aurez besoin des deux lorsque vous nous contactez)

Numéro de modèle : Référence du produit :

60127

LIFETIME

INSTRUCCIONES DE ENSAMBLE

For English, see page 1.

Pour le français, voir la page 2.



CASETA EXTERIOR DE 6,10 m x 2,44 m

Las casetas Lifetime® son diseñadas para ser sólidas y durables. Nos esforzamos por hacer el ensamble lo más fácil posible sin comprometer la calidad. Si se atasque, tenemos las herramientas necesarias para ayudarle:

- **Construya una plataforma**
Construya una plataforma nivelada antes de comenzar.
(vea la página 6 para las instrucciones)
- **Reuna a sus amigos y a su familia**
El ensamble debe realizarse de 3 adultos y unas 4-6 horas.



Para el servicio a clientes en el continente europeo:
Correo electrónico: cs@lifetimeproducts.eu

INSTRUMENTAL REQUERIDO (NO INCLUIDO)



ÍNDICE

Leyenda de íconos.....	4
Advertencias y avisos.....	5
Ensamble de la plataforma.....	6
Ensamble de las cerchas.....	11
Ensamble de las fachadas.....	18
Ensamble de las puertas.....	22
Ensamble de los tragaluces.....	33
Ensamble del piso.....	37
Ensamble de los muros.....	42
Identificador de piezas.....	49
Instalación de la estantería.....	53
Ensamble del tejado.....	57
Instalación de las hojas de ventana.....	79
Instalación de hojas de ventana.....	81
Instalación de los accesorios.....	84
Instalación del kit de la carga de nieve.....	86
Alineación de las puertas.....	90
Anclaje de la caseta.....	92
Limpieza y cuidado.....	95
Registro.....	96
Garantía.....	99

¿NECESITA AYUDA? ¡LLÁMENOS!

Los Expertos de ensamble Lifetime® ofrecen respuestas rápidas y servicio valorado.

Lláme al **1.800.225.3865**

De lunes hasta viernes 7:00 hr-17:00 hr (HNR)
y sábado 9:00 hr-13:00 hr (HNR)

Web: www.lifetime.com/instructions

Live Chat: www.lifetime.com/instructions

MODELO E ID DEL PRODUCTO (necesitará los dos al contactarnos)

Número de modelo: ID del producto:

60127



ICON LEGEND / LÉGENDE DES ICÔNES / LEYENDA DE ÍCONOS



- Indicates special heed should be taken when reading.
- Indique qu'une attention spéciale doit être prise lors de la lecture.
- Indica que uno debe prestar atención al leer.



- Indicates the parts to be used for a section.
- Indique les pièces à utiliser pour une section.
- Indica las piezas que se usarán en una sección.



- Indicates no parts required for a specific section.
- Indique qu'aucune pièce n'est requise pour une section précise.
- Indica que no se necesitan partes en una sección específica.



- Indicates the hardware to be used for a section.
- Indique la quincaillerie à utiliser pour une section.
- Indica el herraje que se usará en una sección.



- Indicates no hardware required for a specific page.
- Indique qu'aucun matériel n'est requis pour une page précise.
- Indica que no se necesita herraje en una página específica.



- Indicates the tools to be used for a section.
- Indique les outils à utiliser pour une section.
- Indica el instrumental que se usará en una sección.



- Indicates to use/not to use an electric drill for a specific step.
- Indique quand utiliser ou ne pas utiliser une perceuse électrique pour une étape précise.
- Indica usar o no usar un taladro eléctrico en un paso específico.



- These Nuts are centerlock nuts. They are designed to be tight; therefore, they will be harder to tighten. Tighten until flush with the metal or plastic.
- Ces écrous sont des écrous de sécurité à blocage central. Ils sont conçus pour être serrés; de ce fait, ils seront plus difficiles à resserrer. Serrer jusqu'à ce qu'ils soient au ras du métal ou plastique.
- Estas tuercas son tuercas de bloqueo central. Ellas son diseñadas para ser apretadas; entonces, ellas serán más difícil ajustar. Apretar hasta que ellas estén al ras del metal o plástico.



WARNINGS & NOTICES / AVERTISSEMENTS ET AVIS / ADVERTENCIAS Y AVISOS

English:

- **Failure to follow these warnings may result in serious injury or property damage and will void warranty.**
- To ensure safety, do not attempt to assemble this product without following the instructions carefully.
- Consult all local building codes to verify if the shed requires a building permit.
- Verify the foundation is completely level before assembling the shed.
- Be aware that plastic pieces can be damaged by overtightening the screws. To avoid damage, we strongly recommend the use of a drill with a low torque setting. A #2 Phillips screwdriver may also be used.
- Three capable adults are required for assembly.
- All who participate in the assembly process should wear safety glasses throughout the assembly.
- If using a ladder during assembly, use extreme caution.
- In heavy snowfall areas, we recommend removing snow from the roof.
- Do not use or store hot objects near the product.
- Proper and complete assembly are essential to reduce the risk of accident or injury.
- We strongly recommend anchoring your shed when it is finished. The last section, Shed Anchoring, in this manual, shows the hardware you will need to complete the anchoring. You can find the hardware at your local hardware store.
- **Most injuries are caused by misuse and/or not following instructions. Use caution when using this product.**

Français :

- **Un manquement de suivre ces avertissements peut entraîner des blessures graves ou des dommages à la propriété et annulera la garantie.**
- Afin d'assurer la sécurité, ne pas tenter d'assembler ce produit sans suivre les instructions avec attention.
- Consulter tous les codes du bâtiment afin de vérifier si l'abri nécessite un permis de bâtiment.
- Vérifier que la fondation soit complètement à niveau avant l'assemblage de l'abri.
- Être conscient que les pièces de plastique peuvent être endommagées en serrant trop les vis. Afin d'éviter les dommages, nous recommandons fortement l'utilisation d'une perceuse à faible couple. Une tournevis cruciforme n° 2 peut aussi être utilisé.
- Trois adultes en bonne condition physique sont nécessaires pour l'assemblage.
- Tout ceux qui participent au processus de l'assemblage doivent porter des lunettes de sécurité tout au long de l'assemblage.
- Si une échelle est utilisée pour l'assemblage, il faut être extrêmement prudent.
- Dans les zones de grandes tombées de neige, nous recommandons d'enlever celle-ci du toit.
- Ne pas utiliser ou entreposer d'objet très chaud près de ce produit.
- Un bon assemblage complet est nécessaire pour réduire le risque d'accident ou de blessure.
- Nous recommandons fortement d'ancrer votre remise lorsque l'assemblage est terminé. La dernière section, Ancrage de la remise, de ce manuel démontre les matériaux nécessaires afin de compléter l'ancrage. Les matériaux se trouvent dans la quincaillerie locale.
- **La majorité des blessures sont causées par une mauvaise utilisation et/ou le non suivi des instructions. Être prudent lorsque vous utilisez ce produit.**

Español:

- **No seguir estas advertencias puede resultar en lesiones graves o daños a la propiedad y anulará la garantía.**
- A fin de garantizar la seguridad, no intentar ensamblar este producto sin seguir cuidadosamente las instrucciones.
- Consultar todos los códigos de construcción locales para verificar si la caseta requiere un permiso de construcción.
- Verificar que el concreto esté nivelado completamente antes de ensamblar la caseta.
- Tener en cuenta que las piezas de plástico pueden dañarse si los tornillos se aprietan de más. A fin de evitar daños, lo exhortamos a que use un taladro con función de torque bajo. También puede usarse un desatornillador Phillips no. 2.
- Se necesitan tres adultos para el ensamble.
- Todos los que participen en el proceso de ensamble debe usar anteojos de seguridad durante todo el ensamble.
- Si se usa una escalera durante el ensamblado, es preciso tener cuidado.
- En áreas de nevadas fuertes, recomendamos retirar la nieve del techo.
- No usar ni guardar objetos calientes cerca del producto.
- El ensamble correcto y completo son esenciales para reducir el riesgo de accidente o lesión.
- Lo exhortamos a anclar la caseta al terminar el ensamble. La última sección, Anclaje de la caseta, en este manual muestra el herraje necesaria para terminar el anclaje. Se encuentra el herraje en la ferretería local.
- **La mayoría de las lesiones suceden a causa del mal uso y/o por no seguir las instrucciones. Tener precaución al usar este producto.**

PLATFORM CONSTRUCTION / CONSTRUCTION DE LA PLATE-FORME / CONSTRUCCIÓN DE LA PLATAFORMA



• You must provide a platform on which to assemble your shed. Proper building permit documentation may be required in your neighborhood. Consult all local building codes prior to assembling the shed. Before beginning assembly, you must pour or construct a platform. There are two types:

- Concrete
- Wood Frame

Select the type, but know the surface must be leveled and flat before installation. If the surface is not properly leveled and flat, the shed will not assemble correctly. Proper surface leveling will save you time in the long run, so please do not ignore this step.

We recommend a Concrete platform. It will be the most durable and long-lasting choice. The platform you choose must be built above ground in order to avoid water pooling inside the shed. All lumber must be rated for outdoor use!



• Il faut construire une plate-forme sur laquelle on peut assembler l'abri. Il est possible que le quartier exige une documentation visant les permis de construire. Consulter tous les codes du bâtiment locaux, ainsi que les décrets des villes et comtés, pour vérifier que la construction de l'abri extérieur n'exige pas un permis de construire. Avant de commencer l'assemblage, il faut couler ou construire une plate-forme. Il y a deux styles :

- Béton
- Cadre à bois

Sélectionner le style, mais sachez que la surface d'installation doit être de niveau et plate. Si la surface n'est pas correctement de niveau et plate, l'assemblage de l'abri ne se fera pas correctement. On gagnera du temps sur le long terme grâce à une surface bien de niveau, alors ne pas négliger cette étape. **Nous recommandons une plate-forme en béton. Ce choix sera le plus durable. La plate-forme doit être construite au-dessus du sol afin d'éviter l'accumulation d'eau à l'intérieur de l'abri. Tous le bois d'oeuvre doit être approuvé pour l'usage à l'extérieur !**



• Es preciso construir una plataforma sobre la cual uno puede ensamblar la caseta. Puede suceder que en el vecindario se requiera la documentación apropiada de un permiso de construcción. Consultar todos los códigos locales de construcción y los reglamentos de la ciudad y el municipio para verificar que la construcción de la caseta no requiere un permiso de construcción. Antes de comenzar el ensamble, es necesario verter o construir una plataforma. Hay dos clases:

- Concreto
- Armazón de madera

Seleccionar la clase, mas sepa que la superficie debe estar nivelada y plana antes de comenzar el armado. Si la superficie no está nivelada y plana de manera adecuada, la caseta no podrá armarse correctamente. La nivelación de la superficie le ahorrará tiempo de trabajo, por lo tanto, le pedimos que el usuario no ignore este paso. **Recomendamos una plataforma hecho de concreto. Será la elección más perdurable. La plataforma debe ser construida arriba del suelo para evitar el aflujo de agua dentro de la caseta. ¡Toda la madera debe estar clasificada para el uso externo!**



► SECTION 1 (CONTINUED) / SECTION 1 (SUITE) / SECCIÓN 1 (CONTINUACIÓN)

CONCRETE REQUIRED / BÉTON REQUIS / CONCRETO REQUERIDO



2 yd³ (1,53 m³)

1.1

CONCRETE PLATFORM / PLATE-FORME EN BÉTON / PLATAFORMA DE CONCRETO

- The concrete should be approximately 4" (10,2 cm) thick. The actual dimensions of the shed, at its widest and longest points, are 240" x 96" (6,05 m x 2,44 m). Ensure you select a site that will accommodate these measurements. **The floor dimensions are a bit smaller than those of the roof; therefore, you will need to build a level surface of 238 1/4" x 93 1/2" (6,05 m x 2,38 m).**
- Le béton doit être un épaisseur de 10,2 cm (4 po). Les dimensions réelles de votre abri, aux points les plus larges et longs, sont 6,10 m x 2,44 m (240 po x 96 po). Veiller sélectionner un site qui accommodera ces dimensions. **Les dimensions du plancher de votre abri sont plus petites que le toit; ensuite, il faut créer une surface de niveau de 6,05 m x 2,38 m (238 1/4 po x 93 1/2 po).**
- El concreto debe tener, por lo menos, 10,2 cm (4 in) de espesor. Las dimensiones reales de la caseta, a sus puntos más anchos y largos, son 6,10 m x 2,44 m (240 in x 96 in). Asegurarse de seleccionar un sitio que acomodará estas medidas. **Las dimensiones del piso de la caseta son más pequeñas que el tejado; entonces, necesitará crear una superficie nivelada de 6,05 m x 2,38 m (238 1/4 in x 93 1/2 in).**

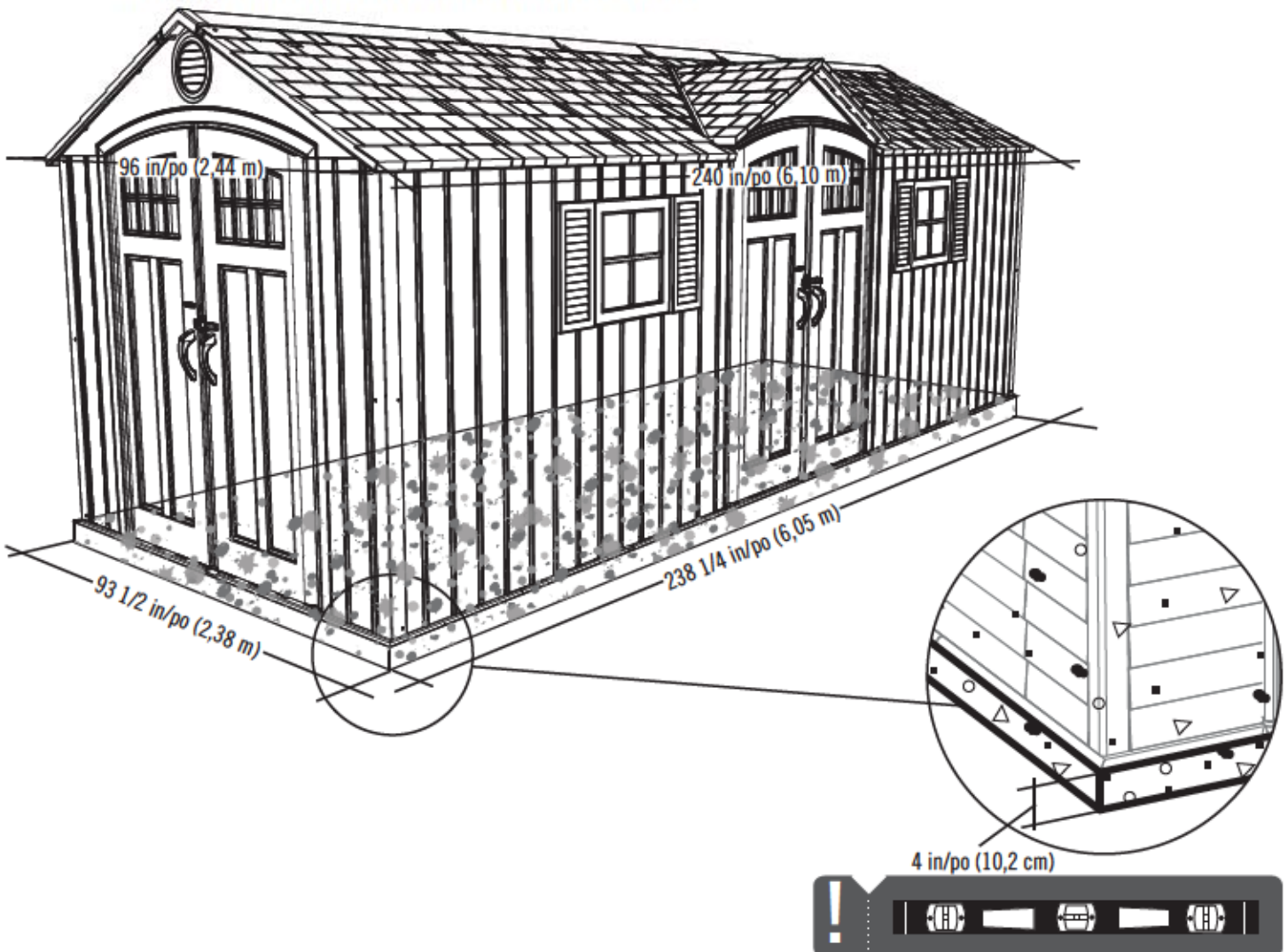

► SECTION 1 (CONTINUED) / SECTION 1 (SUITE) / SECCIÓN 1 (CONTINUACIÓN)

WOOD REQUIRED / BOIS REQUIS / MADERA REQUERIDA



1.2

WOOD PLATFORM / PLATE-FORME EN BOIS / PLATAFORMA DE MADERA

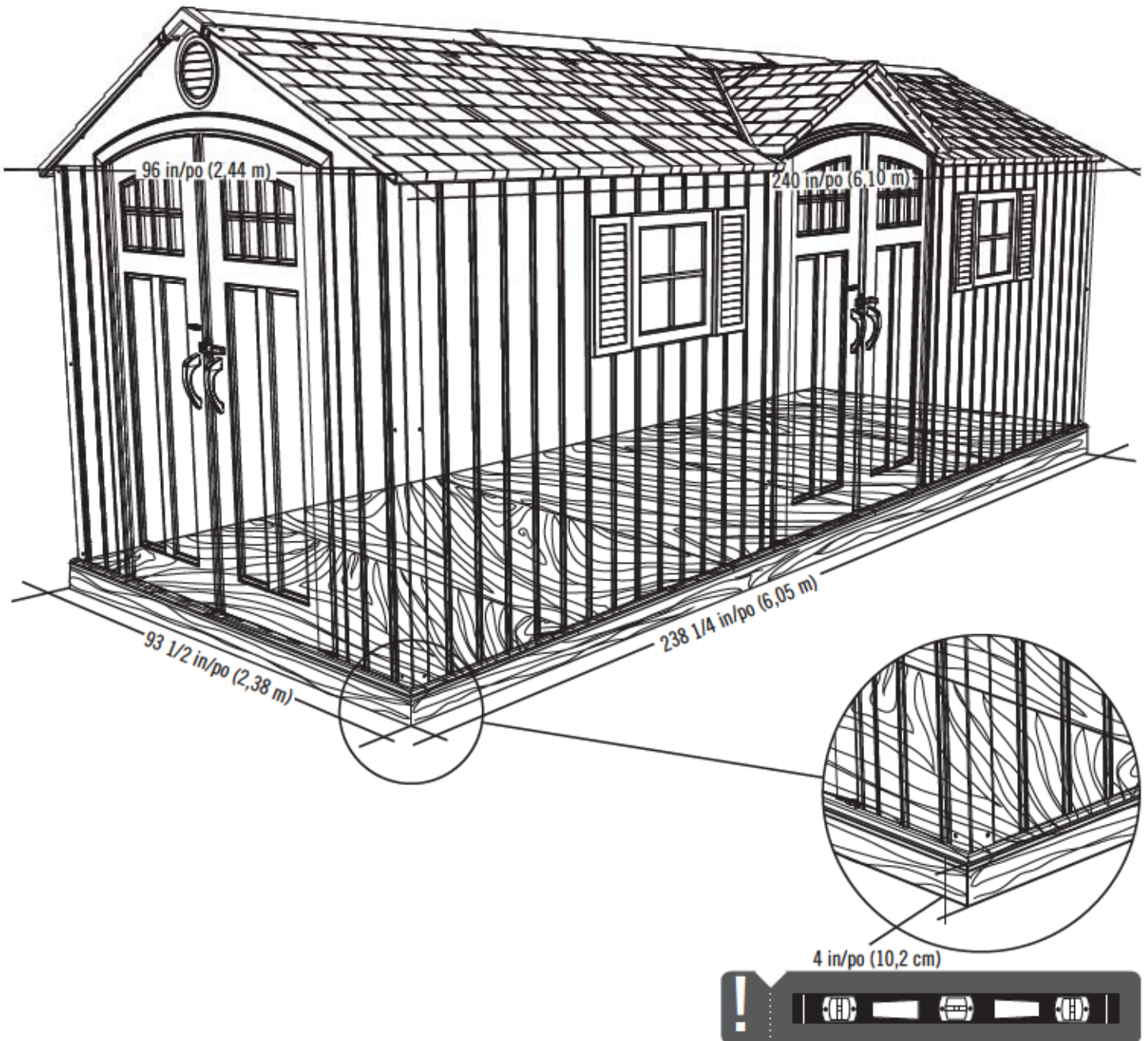

► SECTION 1 (CONTINUED) / SECTION 1 (SUITE) / SECCIÓN 1 (CONTINUACIÓN)

TOOLS, PARTS, AND HARDWARE REQUIRED / OUTILS, PIÈCES, ET QUINCAILLERIE REQUIS / INSTRUMENTAL, PIEZAS, Y HERRAJE REQUERIDOS



2 in/po x 4 in/po x 238 1/4 in/po (5,1 cm x 10,2 cm x 6,05 m) (x2)



2 in/po x 4 in/po x 90 1/2 in/po (5,1 cm x 10,2 cm x 2,30 m) (x16)



16d 3 1/2 in/po (16d x 8,89 cm) (x64)

1.2.1

WOOD PLATFORM / PLATE-FORME EN BOIS / PLATAFORMA DE MADERA

- Ensure all lumber is treated and approved for outdoor use. Build frame to 238 1/4" x 93 1/2" (6,05 m x 2,38 m) (**outside dimensions**).
- Veiller à ce que votre bois d'œuvre à été traité et approuvé pour l'utilisation à l'extérieur. Construire un cadre de 6,05 m x 2,38 m (238 1/4 po x 93 1/2 po) (**dimensions extérieures**).
- Asegurarse que la madera es tratada y aprobada para el uso externo. Construir el armazón a 6,05 m x 2,38 m (238 1/4 in x 93 1/2 in) (**dimensiones exteriores**).

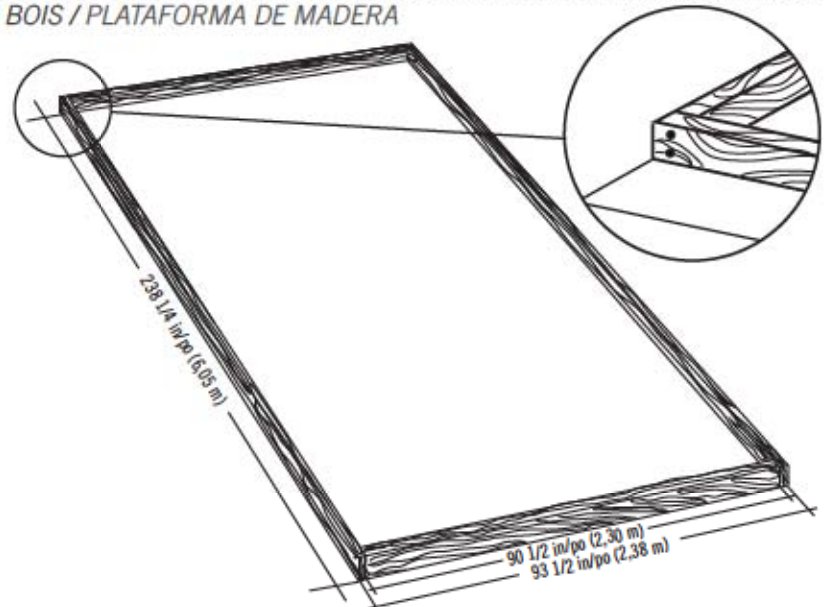

x8

1.2.2

- To ensure studs are in the correct location for nailing plywood in the next step, start measuring from the corner 16" (40,1 cm), and then measure from center to center.
- Pour être sûr d'avoir les montants aux endroits corrects pour clouer le contreplaqué dans le prochaine étape, commencer à mesurer à partir de cette montant 40,1 cm (16 po) vers le centre du deuxième montant. Ensuite, mesurer de centre à centre pour les montants restants.
- Para asegurarse que los montantes están en las ubicaciones correctas para el contrachapado en el paso siguiente, comenzar a medir desde el borde del montante hasta el centro del próximo montante 40,1 cm (16 in). Luego, tomar la medida de centro a centro en los montantes restantes.



x56

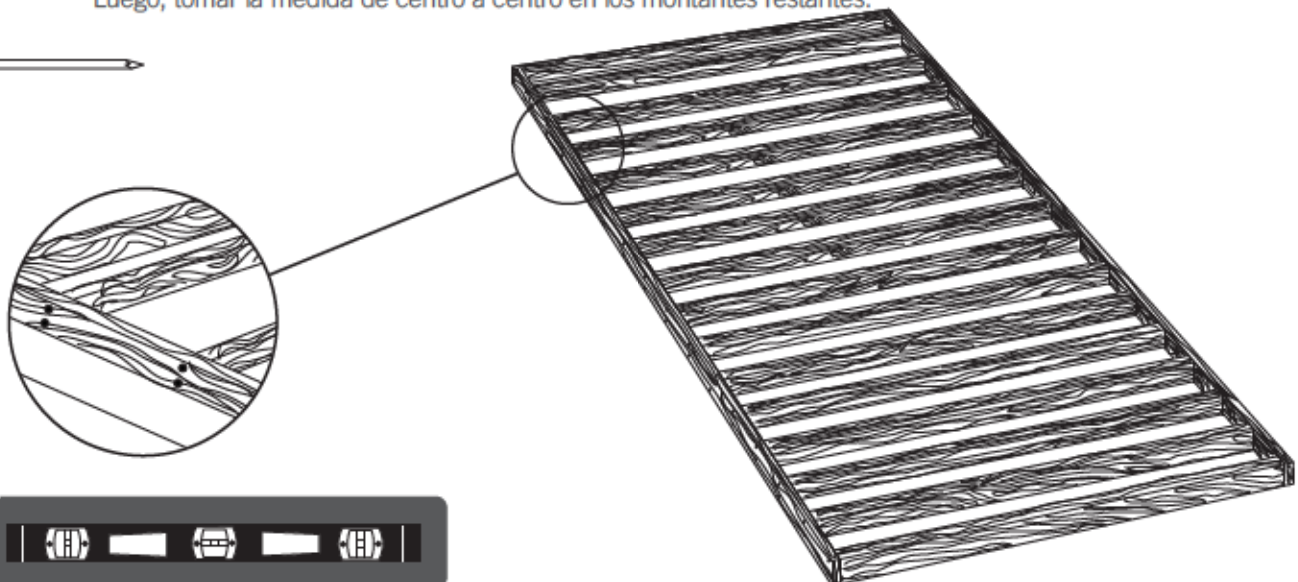

SECTION 1 (CONTINUED) / SECTION 1 (SUITE) / SECCIÓN 1 (CONTINUACIÓN)

TOOLS, PARTS, AND HARDWARE REQUIRED / OUTILS, PIÈCES, ET QUINCAILLERIE REQUIS / INSTRUMENTAL, PIEZAS, Y HERRAJE REQUERIDOS



48 in/po x 93 1/2 in/po x 3/4 in/po
(1,22 m x 2,38 m x 19,1 mm) (x4)



46 1/4 in/po x 93 1/2 in/po x 3/4 in/po
(118 cm x 2,38 m x 19,1 mm) (x1)

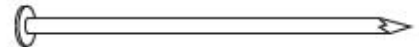

8d 2 in/po (8d 5,08 cm) (x96)

1.2.3

- Square the frame, measuring from corner to corner. **Measurement A & B should be about the same length.**
- Carrer le cadre en mesurant d'angle à angle. **La mesure « A » et « B » doivent être à peu près la même longueur.**
- Cuadrar el armazón midiendo de esquina a esquina. **La medida «A» y «B» deben ser aproximadamente el mismo largo.**

! A = B

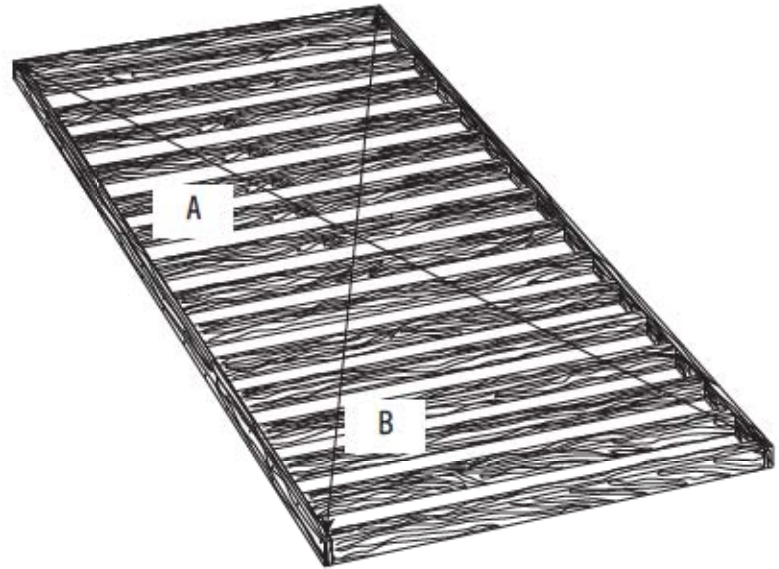

1.2.4

- Using nails, fasten the plywood to the frame. Then, drill 5/16" (8 mm) holes for drainage.
- En utilisant des clous, attacher bien le contreplaqué au cadre. Ensuite, percer des trous de 8 mm pour le drainage.
- Usando unos clavos, sujetar el contrachapado al armazón. Entonces, taladrar agujeros de 8 mm para el drenaje.

46 1/4 in/po x 93 1/2 in/po x 3/4 in/po
(118 cm x 2,38 m x 19,1 mm)



x96

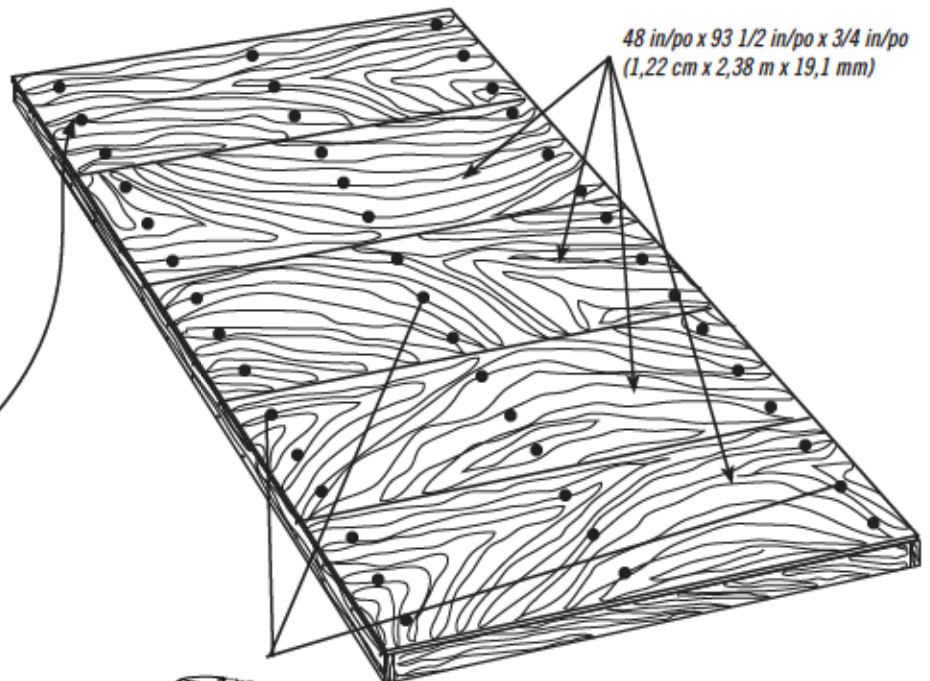

48 in/po x 93 1/2 in/po x 3/4 in/po
(1,22 cm x 2,38 m x 19,1 mm)



Drainage Holes
Trous de drainage
Agujeros para canalización

x45!

2

TRUSS ASSEMBLY / ASSEMBLAGE DES FERMES / ENSAMBLE DE LAS CERCHAS



HARDWARE REQUIRED / QUINCAILLERIE REQUISE / HERRAJE REQUERIDO

Hardware Bag / Sac de quincaillerie / Bolsa de herraje



DTK (x30)

DTJ (x1)



AHT (x1)



ADJ (14)

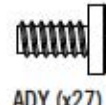

ADY (x27)



ADK (x56)



CXK (x2)



11 9/16 in/po (29,4 cm)

ADH (x7)



PARTS REQUIRED / PIÈCES REQUISES / PIEZAS REQUERIDAS

Metal Parts / Pièces en métal / Piezas de metal



58 1/4 in/po (1,47 m)

DSP (x1)



50 9/16 in/po (1,28 m)

DSQ (x2)



50 9/16 in/po (1,28 m)

DSR (x11)



34 1/8 in/po (86,7 cm)

DSO (x1)

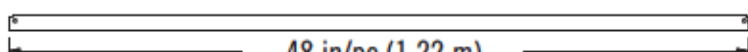

48 in/po (1,22 m)

AFG (x7)



AIP (x7)



8 7/16 in/po (21,4 cm)

DSN (x1)



25 7/8 in/po (65,7 cm)

DSM (x1)

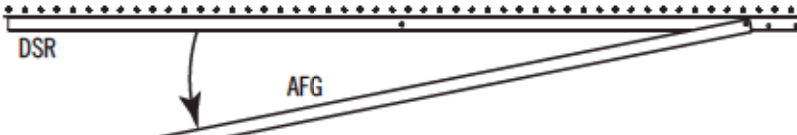

DSR

AFG



• Sometimes during shipping, the Truss Brace (AFG) slides over the back of the Truss Gutter Channel (DSQ or DSR). The two pieces are the same color. If you think you're missing a Truss Brace, check to see if it is stuck to the back of the Truss Gutter Channel, and separate the two.

• Durant le transport, parfois le support de ferme (AFG) glisse par-dessus l'arrière du canal de ferme (DSQ ou DSR). Les deux pièces sont du même couleur. Si vous pensez que vous n'avez pas de support de ferme, vérifiez s'il y a un support de ferme adhérent à l'arrière du canal de ferme, et séparez les deux.

• Durante el transporte, a veces el soporte de cercha (AFG) desliza sobre el dorso del canal de cercha (DSQ o DSR). Las dos piezas son de la misma color. Si piensas que le falta un soporte de cercha, verifica si haya un soporte pegado al dorso del canal de cercha, y separe las dos.



TOOLS REQUIRED / OUTILS REQUIS / INSTRUMENTAL REQUERIDO



7/16 in/po (11 mm) (x2)



3/8 in/po (10 mm) (x2)

► SECTION 2 (CONTINUED) / SECTION 2 (SUITE) / SECCIÓN 2 (CONTINUACIÓN)

TOOLS AND PARTS REQUIRED / OUTILS ET QUINCAILLERIE REQUIS / INSTRUMENTAL Y HERRAJE REQUERIDOS



3/8 in/po (x2)
(10 mm) (x2)



DTK (x8)



ADK (x8)

2.1

SIDE TRUSSES (x2) / FERMES LATÉRIELLES (x2) / CERCHAS LATERALES (x2)

- Attach a **Connector (AIP)** to the end of two **Truss Gutter Channels (DSQ & DSR)** as shown.
- Faire glisser un **raccord (AIP)** sur les extrémités des **canaux de gouttière (DSQ & DSR)** comme illustré.
- Deslizar un **connector (AIP)** sobre los extremos de los **canalones de la cercha (DSQ & DSR)** como se muestra.

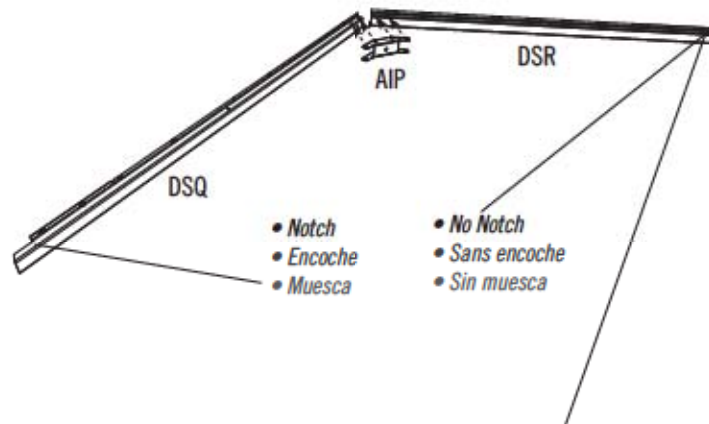

- **Note:** Channel (DSR) has no notch at the end.
- **Remarque :** Le canal (DSR) n'a pas d'encoche à l'extrémité.
- **Nota:** El canalón (DSR) no tiene una muesca al extremo.

2.2

- Attach a **Connector (AIP)** to the end of the **Truss Gutter Channels (DSQ & DSR)** as shown.
- Fixer un **raccord (AIP)** à l'extrémité des **canaux de gouttière (DSQ et DSR)** comme illustré.
- Fijar un **connector (AIP)** a los extremos de los **canalones de la cercha (DSQ y DSR)** como se muestra.

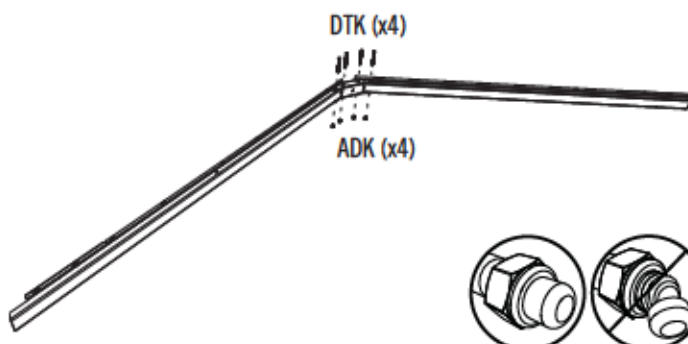

2.3

- Slide a **Truss Brace (AFG)** onto the Truss Gutter Channels as shown.
- Faire glisser un **support de la ferme (AFG)** sur les canaux de gouttière comme illustré.
- Deslizar un **soporte de la cercha (AFG)** sobre los canalones de la cercha como se muestra.

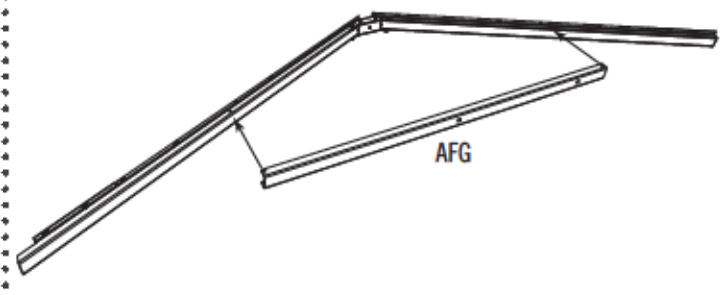

► SECTION 2 (CONTINUED) / SECTION 2 (SUITE) / SECCIÓN 2 (CONTINUACIÓN)

TOOLS AND PARTS REQUIRED / OUTILS ET QUINCAILLERIE REQUIS / INSTRUMENTAL Y HERRAJE REQUERIDOS



3/8 in/po
(10 mm)



7/16 in/po (x2)
(11 mm) (x2)



ADY (x8)



ADK (x8)



ADJ (x4)

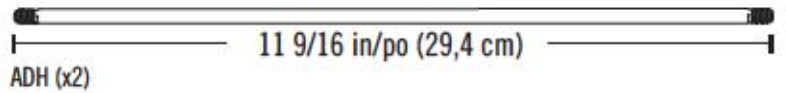

2.4

- Attach the Truss Brace using the hardware included. **Do not overtighten.**
- Fixer le support de la ferme à l'aide de la quincaillerie incluse. **Ne pas serrer excessivement.**
- Fijar el soporte de la cercha usando el herraje incluido. **No apretar demasiado.**

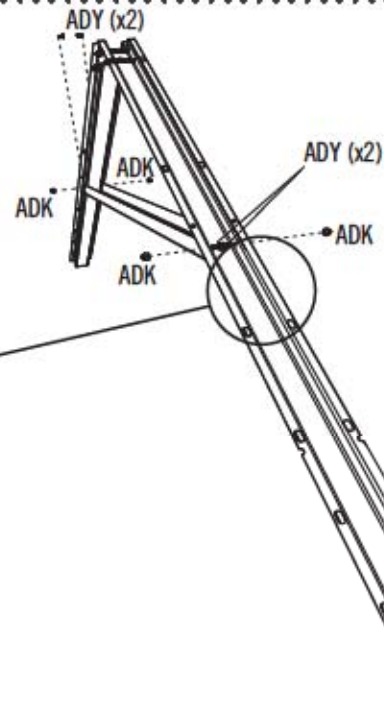
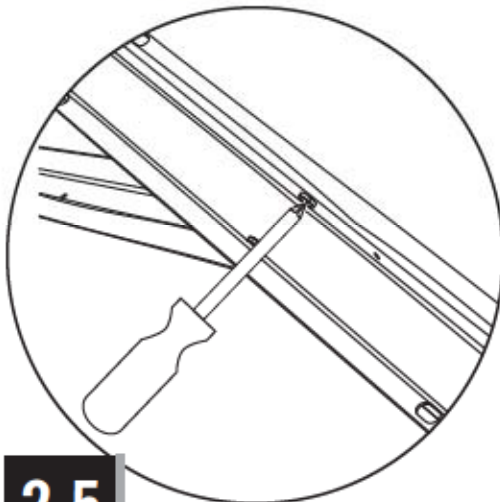

2.5

- Slide a Truss Rod (ADH) through the holes in the Brace and Connector. Secure with two Cap Nuts (ADJ). Repeat the previous steps for a second Side Truss.
- Faire glisser une tige (ADH) à travers les trous dans le support et le raccord. Attacher-le bien à l'aide de deux écrous borgnes (ADJ). Répéter les étapes précédentes pour une deuxième ferme latérale.
- Deslizar una varilla (ADH) a través de los agujeros en el soporte y el conector. Sujetarla con dos tuercas ciegas (ADJ). Repetir los pasos anteriores para una segunda cercha lateral.

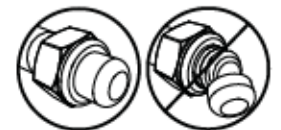
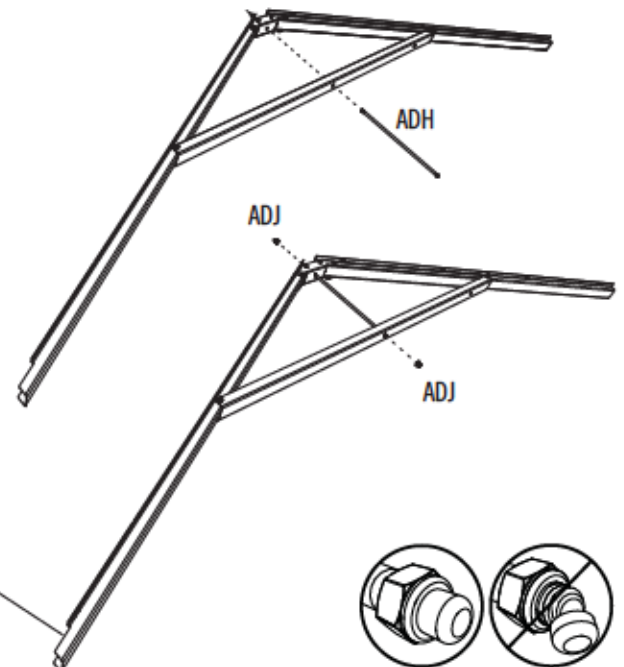

- **Note:** This notched end will face the front of the shed.
- **Remarque :** Cette extrémité encochée fera face à la partie avant de l'abri.
- **Nota:** Este extremo muescado dará a la parte delantera de la caseta.

► SECTION 2 (CONTINUED) / SECTION 2 (SUITE) / SECCIÓN 2 (CONTINUACIÓN)

TOOLS AND PARTS REQUIRED / OUTILS ET QUINCAILLERIE REQUIS / INSTRUMENTAL Y HERRAJE REQUERIDOS



7/16 in/po (x2)
(11 mm) (x2)



3/8 in/po (x2)
(10 mm) (x2)



ADJ (x8)



DTK (x16)

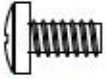

ADY (x16)



ADK (x32)



ADH (x4)

11 9/16 in/po (29,4 cm)

2.6

- Repeat the previous steps for four Truss Assemblies without notches on both ends.
- Répéter les étapes précédentes pour assembler quatre fermes sans les encoches aux deux extrémités.
- Repetir los pasos anteriores para ensamblar cuatro cerchas sin muescas a los dos extremos.

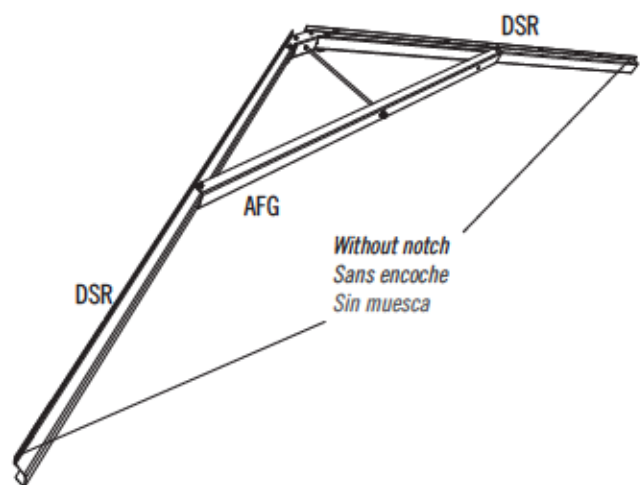
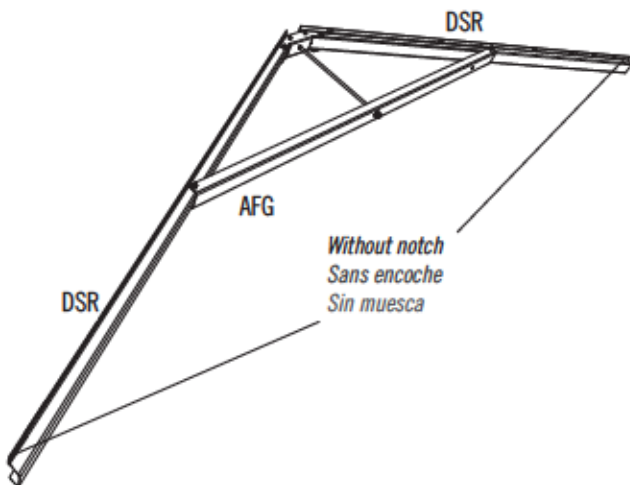
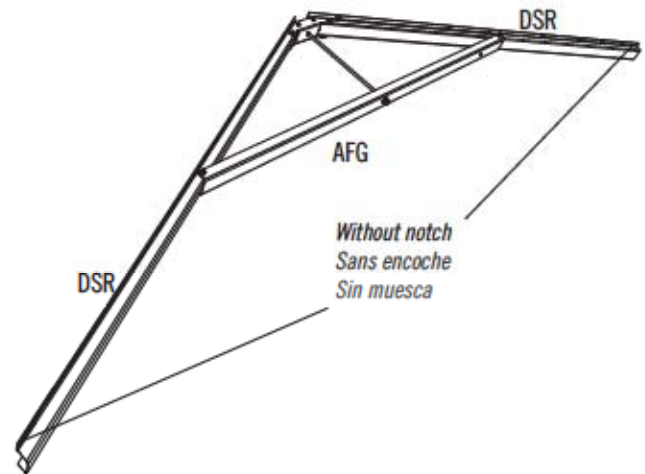
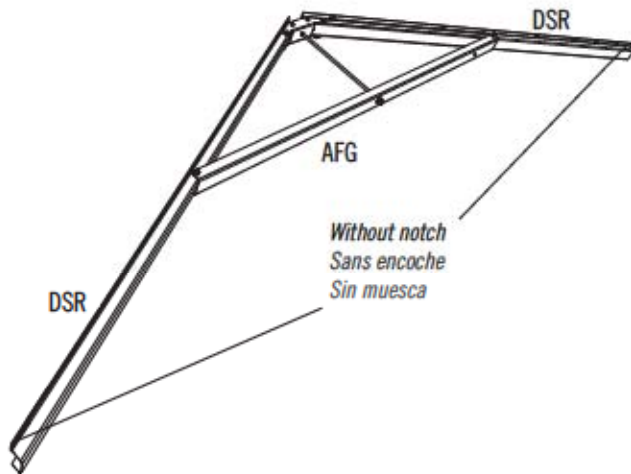

► SECTION 2 (CONTINUED) / SECTION 2 (SUITE) / SECCIÓN 2 (CONTINUACIÓN)

TOOLS AND PARTS REQUIRED / OUTILS ET QUINCAILLERIE REQUIS / INSTRUMENTAL Y HERRAJE REQUERIDOS



3/8 in/po
(10 mm)



DTK (x4)



ADK (x6)

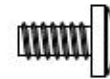

ADY (x2)

2.7

CENTER TRUSS (x1) / FERME CENTRALE (x1) / ARMAZÓN CENTRAL (x1)

- Slide a **Connector (AIP)** over the ends of two **Truss Gutter Channels (DSM & DSR)** as shown.
- Faire glisser un **raccord (AIP)** sur les extrémités des **canaux de gouttière (DSM et DSR)** comme illustré.
- Deslizar un **connector (AIP)** sobre los extremos de los **canalones de la cercha (DSM y DSR)** como se muestra.

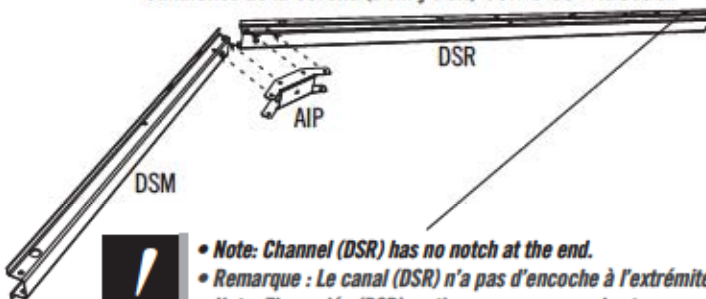

- **Note: Channel (DSR) has no notch at the end.**
- **Remarque : Le canal (DSR) n'a pas d'encoche à l'extrémité.**
- **Nota: El canalón (DSR) no tiene una muesca al extremo.**

2.9

- Slide a **Truss Brace (AFG)** onto the Truss Gutter Channels as shown.
- Faire glisser un **support de la ferme (AFG)** sur les canaux de gouttière comme illustré.
- Deslizar un **soporte de la cercha (AFG)** sobre los canalones de la cercha como se muestra.

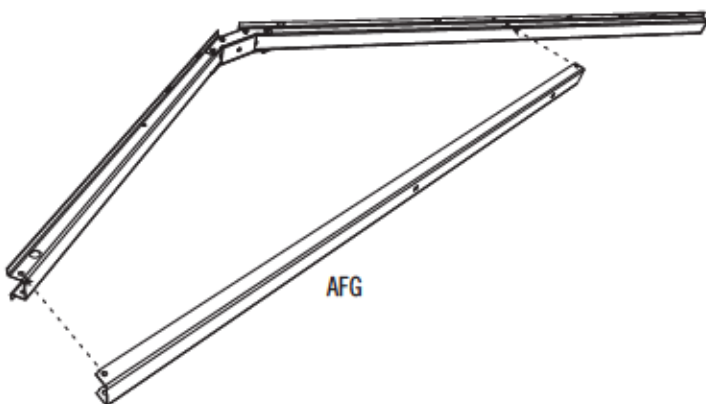

2.8

- Attach a **Connector (AIP)** to the end of two Truss Gutter Channels using the hardware included. **Do not overtighten the Cap Nuts (ADJ).**
- Fixer un **raccord (AIP)** à l'extrémité des canaux de gouttière à l'aide de la quincaillerie incluse. **Ne pas trop serrer les écrous borgnes (ADJ).**
- Fijar un **connector (AIP)** a los extremos de los canalones de la cercha usando el herraje incluido. **No apretar demasiado las tuercas ciegas (ADJ).**

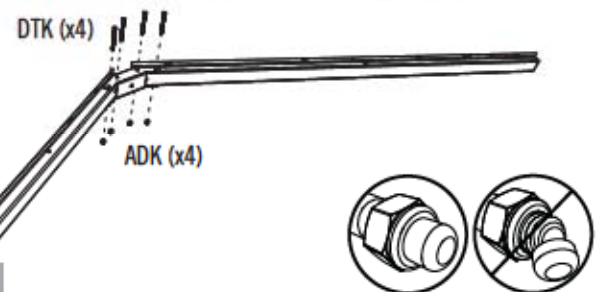

2.10

- Attach the Truss Brace using the hardware included. **Do not overtighten.**
- Fixer le support de la ferme à l'aide de la quincaillerie incluse. **Ne pas serrer excessivement.**
- Fijar el soporte de la cercha usando el herraje incluido. **No apretar demasiado.**

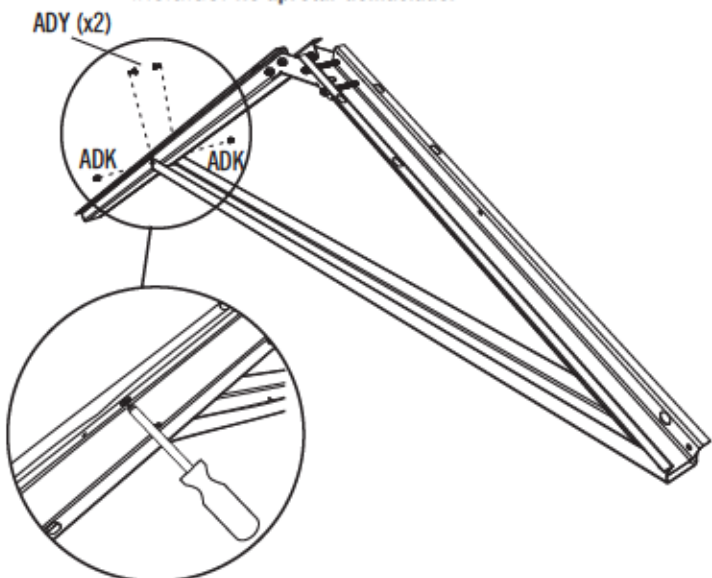

► SECTION 2 (CONTINUED) / SECTION 2 (SUITE) / SECCIÓN 2 (CONTINUACIÓN)

TOOLS AND PARTS REQUIRED / OUTILS ET QUINCAILLERIE REQUIS / INSTRUMENTAL Y HERRAJE REQUERIDOS

3/8 in/po (x2)
(10 mm) (x2)



DTK (x2)



ADK (x1)



DTJ (x1)



CXK (x2)

2.11

- Attach the **Vertical Truss Brace (DSN)** to the Truss. Only finger tighten this **Nut (ADK)** for now.
- Fixer le **support vertical (DSN)** à la ferme. Ne serrer l'**écrou (ADK)** qu'à la main pour le moment.
- Fijar el **soporte vertical (DSN)** a la cercha. Apretar la **tuerca (ADK)** a mano por el momento.

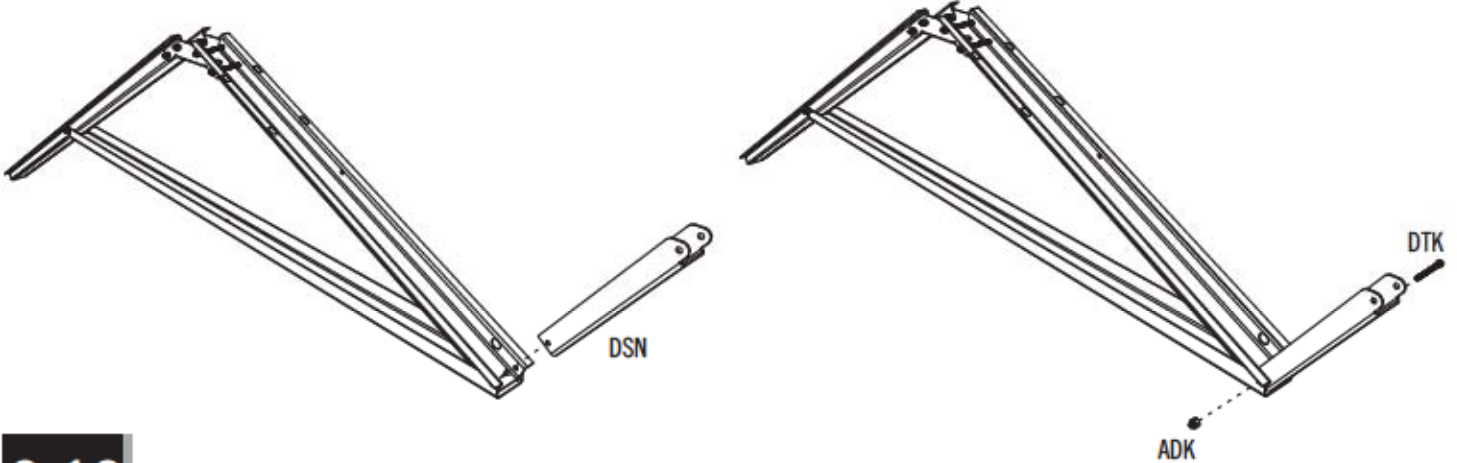

2.12

- Secure the **Horizontal Truss Brace (DSO)** to the Truss with the hardware indicated. **Now, tighten the Nut from Step 2.11.**
- Fixer le **support horizontal (DSO)** à la ferme à l'aide de la quincaillerie incluse. **Maintenant, serrer l'écrou de l'étape 2.11.**
- Fijar el **soporte horizontal (DSO)** a la cercha usando el herraje indicado. **Ahora, apretar la tuerca del paso 2.11.**

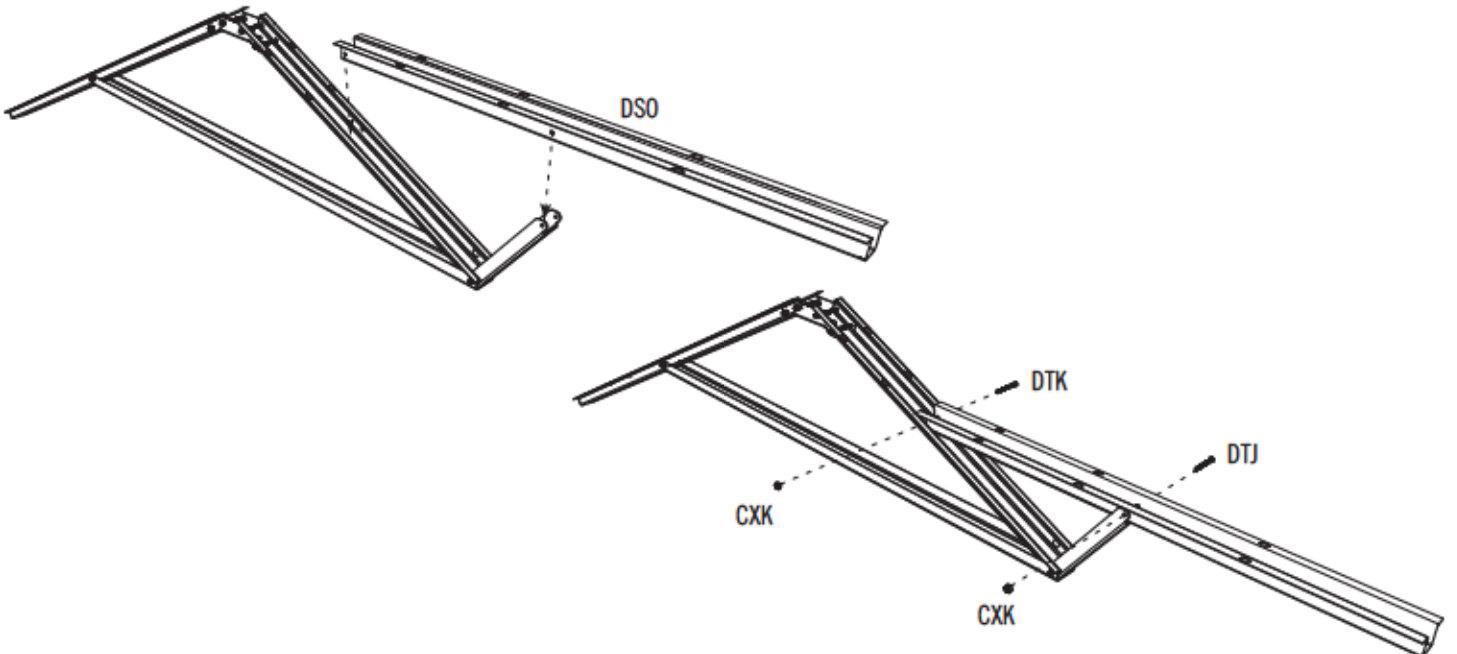

► SECTION 2 (CONTINUED) / SECTION 2 (SUITE) / SECCIÓN 2 (CONTINUACIÓN)

TOOLS AND PARTS REQUIRED / OUTILS ET QUINCAILLERIE REQUIS / INSTRUMENTAL Y HERRAJE REQUERIDOS



7/16 in/po (x2)
(11 mm) (x2)



3/8 in/po (x2)
(10 mm) (x2)



ADJ (x2)



ADH (x1)



AHT (x1)

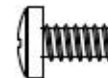

ADY (x1)



ADK (x1)

2.13

- Slide a **Truss Rod (ADH)** through the holes in the Brace and Connector. Secure with two **Cap Nuts (ADJ)**.
- Faire glisser une **tige (ADH)** à travers les trous dans le support et le raccord. Fixer-le bien à l'aide de deux **écrous borgnes (ADJ)**.
- Deslizar una **varilla (ADH)** a través de los agujeros en el soporte y el conector. Fijarla con dos **tuercas ciegas (ADJ)**.

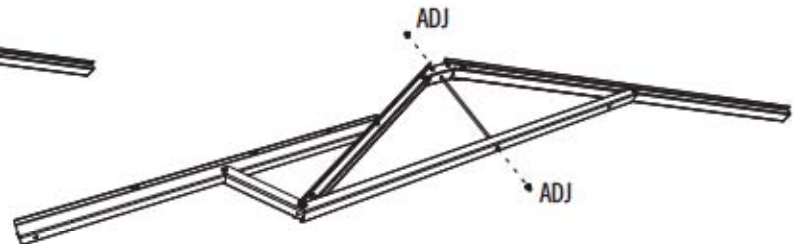
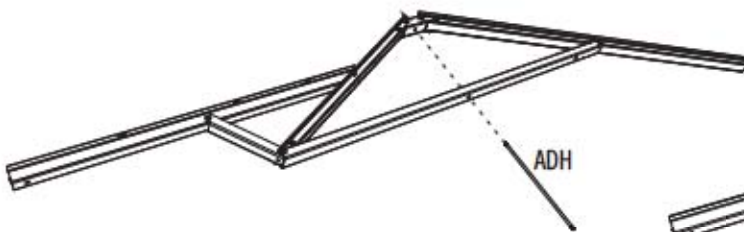

- **Note:** Do not overtighten the **Cap Nuts (ADJ)**.
- **Remarque :** Ne pas trop serrer les **écrous borgnes (ADJ)**.
- **Nota:** No apretar demasiado las **tuercas ciegas (ADJ)**.

2.14

- Only tighten the **Nut (ADK)** by hand in this step.
- Ne serrer l'**écrou (ADK)** qu'à la main à cette étape.
- Sólo apretar la **tuercas (ADK)** a mano en este paso.

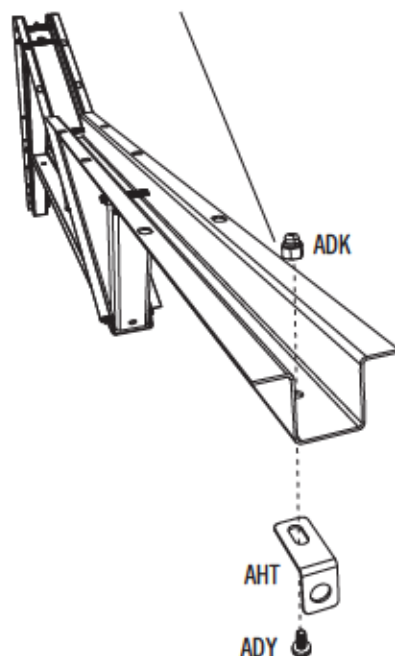

2.15

- Slide the **Support Tube (DSP)** through the hole in the Front Truss Channel and center it.
- Faire glisser le **tube de support (DSP)** à travers le trou dans le canal de gouttière avant et centrer-le.
- Deslizar el **tubo de soporte (DSP)** a través del agujero en el canalón de la cercha delantero y centrarlo.



- **Note:** This end will face the front of the shed.
- **Remarque :** Cette extrémité fera face à la partie avant de l'abri.
- **Nota:** Este extremo dará a la parte delantera de la caseta.

3

GABLE ASSEMBLY / ASSEMBLAGE DES PIGNONS / ENSAMBLE DE LAS FACHADAS



HARDWARE REQUIRED / QUINCAILLERIE REQUISE / HERRAJE REQUERIDO

Hardware Bag / Sac de quincaillerie / Bolsa de herraje

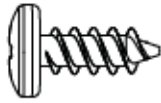

ADZ (x8)



ACB (x2)

Not used / Non utilisée / No utilizado



AGP (x2)

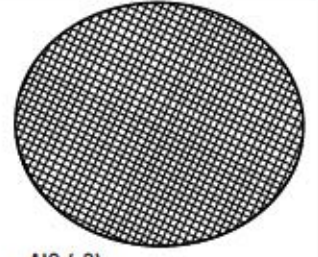

AIQ (x2)



ADW (x10)



ADV (x12)



AEE (x10)



AHS (x4)



PARTS REQUIRED / PIÈCES REQUISES / PIEZAS REQUERIDAS

Metal Parts / Pièces en métal / Piezas de metal

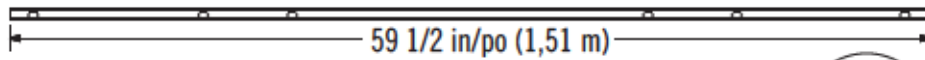

AFE (x1)

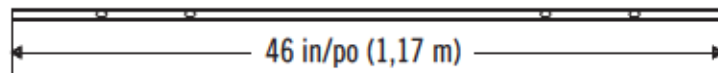

BDD (x1)

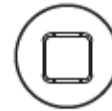

Plastic Parts / Pièces en plastique / Piezas de plástico



BDC (x1)

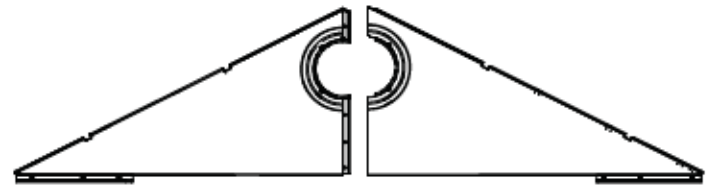

AGI (x1)

AGH (x1)



AGF (x1)



TOOLS REQUIRED / OUTILS REQUIS / INSTRUMENTAL REQUERIDO



► SECTION 3 (CONTINUED) / SECTION 3 (SUITE) / SECCIÓN 3 (CONTINUACIÓN)

TOOLS AND PARTS REQUIRED / OUTILS ET QUINCAILLERIE REQUIS / INSTRUMENTAL Y HERRAJE REQUERIDOS

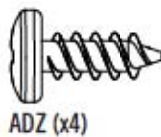

3.1

- Align the holes in the **Left (AGH)** and **Right (AGI)** Side Gable Halves.
- Aligner les trous dans les **pignons latéraux gauche (AGH)** et **droit (AGI)**.
- Alinear los agujeros en las **fachadas laterales izquierda (AGH)** y **derecha (AGI)**.

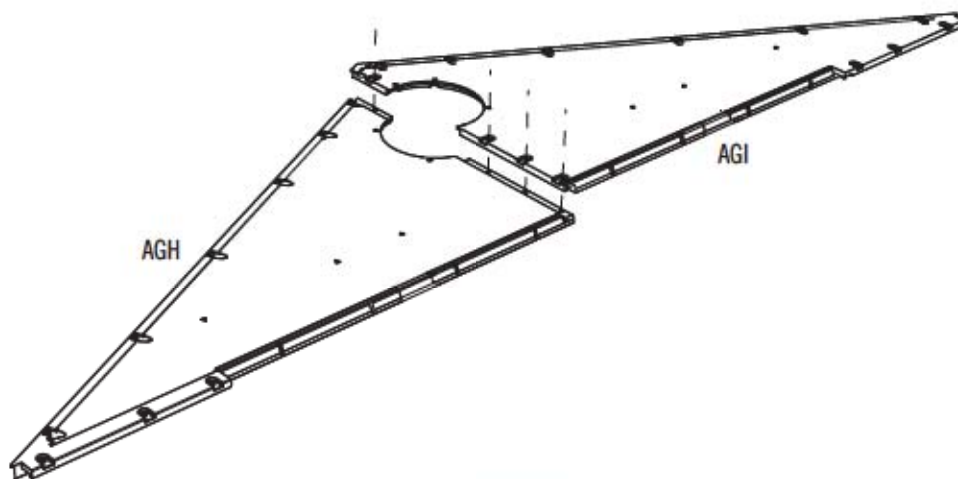

3.2

- Secure the two Gable Halves with four (4) **Screws (ADZ)**.
- Fixer l'un à l'autre à l'aide de quatre (4) **vis (ADZ)**.
- Fijar el uno al otro usando cuatro (4) **tornillos (ADZ)**.

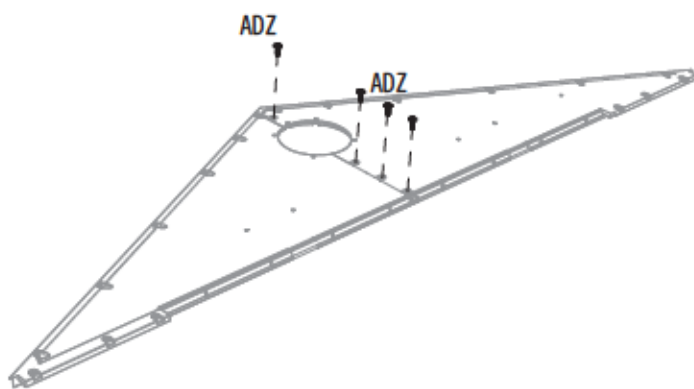

3.3

- Place the **Screen (AIQ)** over the **Vent (AGP)**, and align the five holes in the Vent with those in the Gable.
- Mettre la **moustiquaire (AIQ)** sur l'**évent (AGP)**, et aligner les cinq trous dans l'évent avec ceux du pignon.
- Colocar el **mosquitero (AIQ)** sobre la **rejilla de ventilación (AGP)**, y alinear los agujeros en la rejilla con los de la fachada.

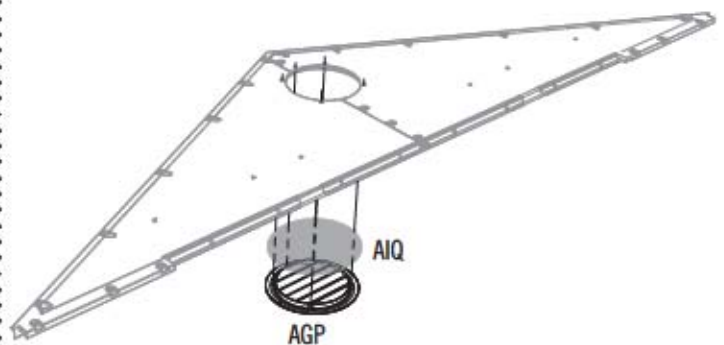

► SECTION 3 (CONTINUED) / SECTION 3 (SUITE) / SECCIÓN 3 (CONTINUACIÓN)

TOOLS AND PARTS REQUIRED / OUTILS ET QUINCAILLERIE REQUIS / INSTRUMENTAL Y HERRAJE REQUERIDOS



ADW (x10)



AEE (x10)



AHS (x2)

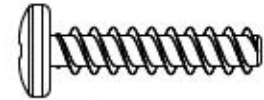

ADV (x4)

3.4

- Secure with the hardware included.
- Fixer-les en utilisant la quincaillerie incluse.
- Fijarlos usando el herraje incluido.

3.5

- Insert an **End Cap (AHS)** into each end of the **Header Bar (BDD)**.
- Insérer un **capuchon (AHS)** dans chaque extrémité du **lindeau (BDD)**.
- Insertar un **tapón (AHS)** en los dos extremos del **dintel (BDD)**.

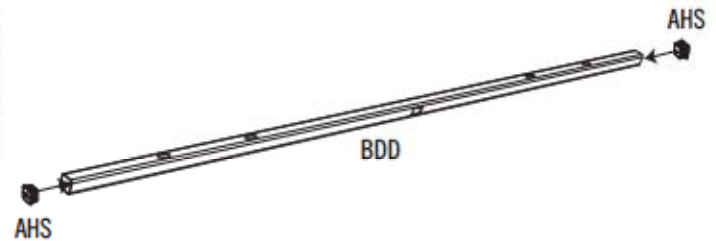
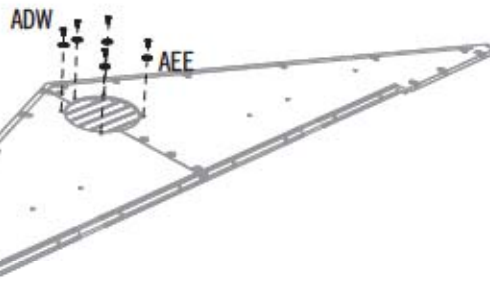

3.6

- Align the holes in the Header with those in the Front Entry Gable. Secure with the hardware included.
- Aligner les trous dans le lindeau avec ceux du pignon d'entrée avant. Fixer-le en utilisant la quincaillerie incluse.
- Alinear los agujeros en el dintel con ellos en la fachada de entrada delantera. Fijarlo usando el herraje incluido.



- **The flat holes face away from the Gable.**
- **Les trous plats doivent être face à l'écart du pignon.**
- **Los agujeros planos dan hacia afuera.**

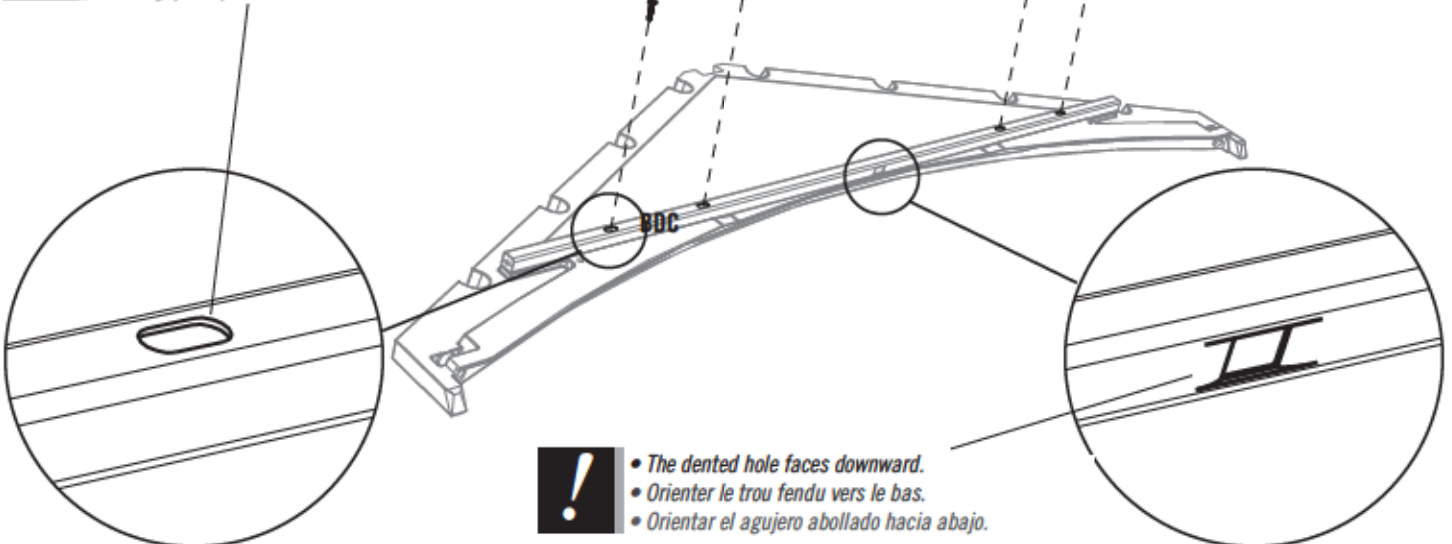

- **The dented hole faces downward.**
- **Orienter le trou fendu vers le bas.**
- **Orienter el agujero abollado hacia abajo.**

► SECTION 3 (CONTINUED) / SECTION 3 (SUITE) / SECCIÓN 3 (CONTINUACIÓN)

TOOLS AND PARTS REQUIRED / OUTILS ET QUINCAILLERIE REQUIS / INSTRUMENTAL Y HERRAJE REQUERIDOS

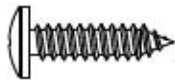

ADW (x5)



AEE (x5)



AHS (x2)

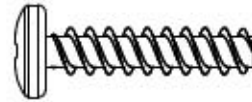

ADV (x6)

3.7

- Place the **Screen (AIQ)** over the **Vent (AGP)**, and align the five holes in the Vent with those in the **Entry Gable (AGF)**.
- Mettre la **moustiquaire (AIQ)** sur l'**évent (AGP)**, et aligner les cinq trous dans l'évent avec ceux du **pignon d'entrée (AGF)**.
- Colocar el **mosquero (AIQ)** sobre la **rejilla de ventilación (AGP)**, y alinear los agujeros en la rejilla con los de la **fachada de entrada (AGF)**.

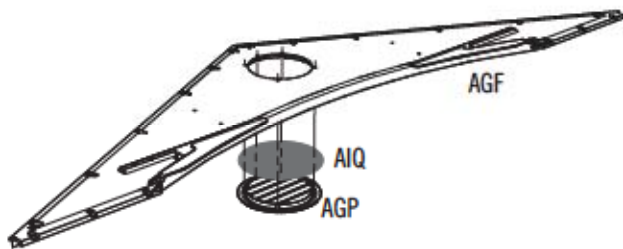

3.8

- Secure with the hardware included.
- Fixer-les en utilisant la quincaillerie incluse.
- Fijarlos usando el herraje incluido.

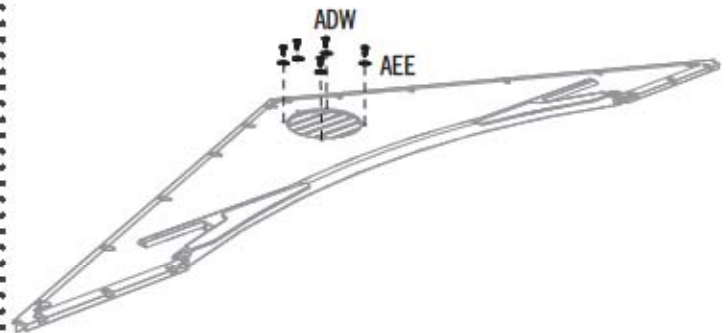

3.9

- The flat holes face away from the Gable.
- Les trous plats doivent être face à l'écart du pignon.
- Los agujeros planos dan hacia afuera.

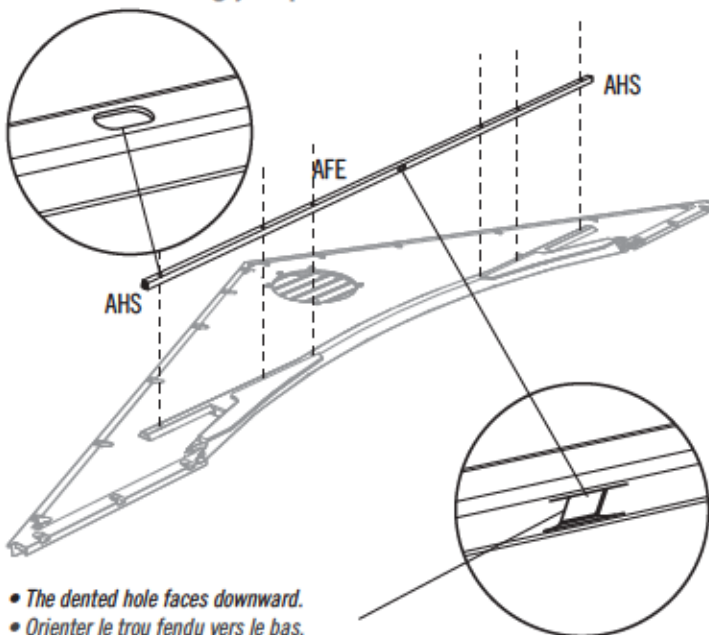

- The dented hole faces downward.
- Orienter le trou fendu vers le bas.
- Orientar el agujero abollado hacia abajo.

3.10

- Secure with the hardware included.
- Fixer-le en utilisant la quincaillerie incluse.
- Fijarlo usando el herraje incluido.

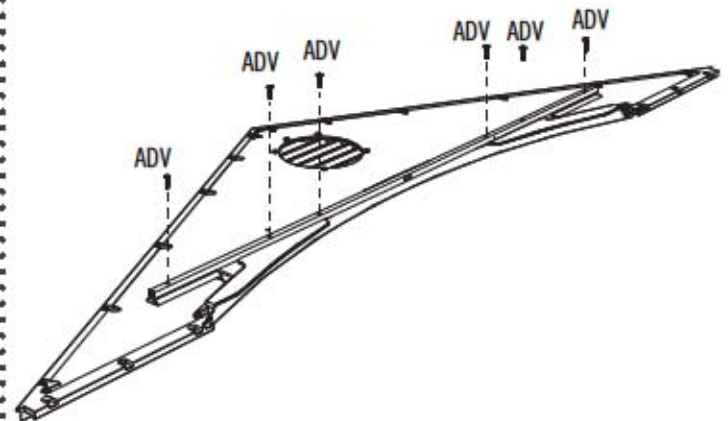

4

LEFT DOOR ASSEMBLY / ASSEMBLAGE DE LA PORTE GAUCHE / ENSAMBLE DE LA PUERTA IZQUIERDA



HARDWARE REQUIRED / QUINCAILLERIE REQUISE / HERRAJE REQUERIDO

Hardware Bag / Sac de quincaillerie / Bolsa de herraje

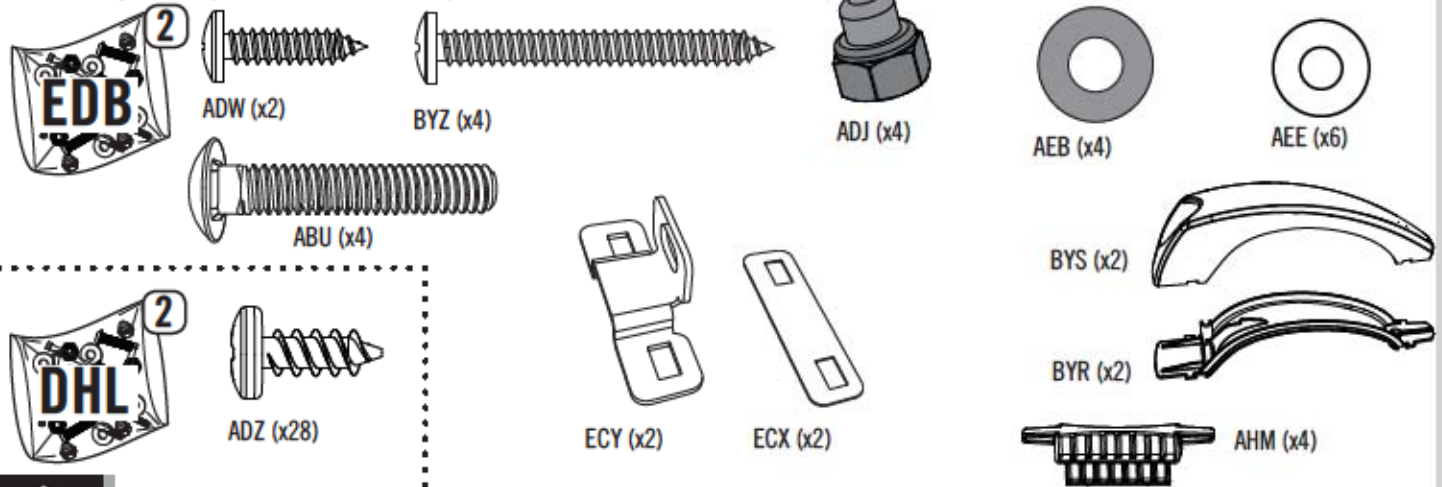

PARTS REQUIRED / PIÈCES REQUISES / PIEZAS REQUERIDAS

Metal Parts / Pièces en métal / Piezas de metal

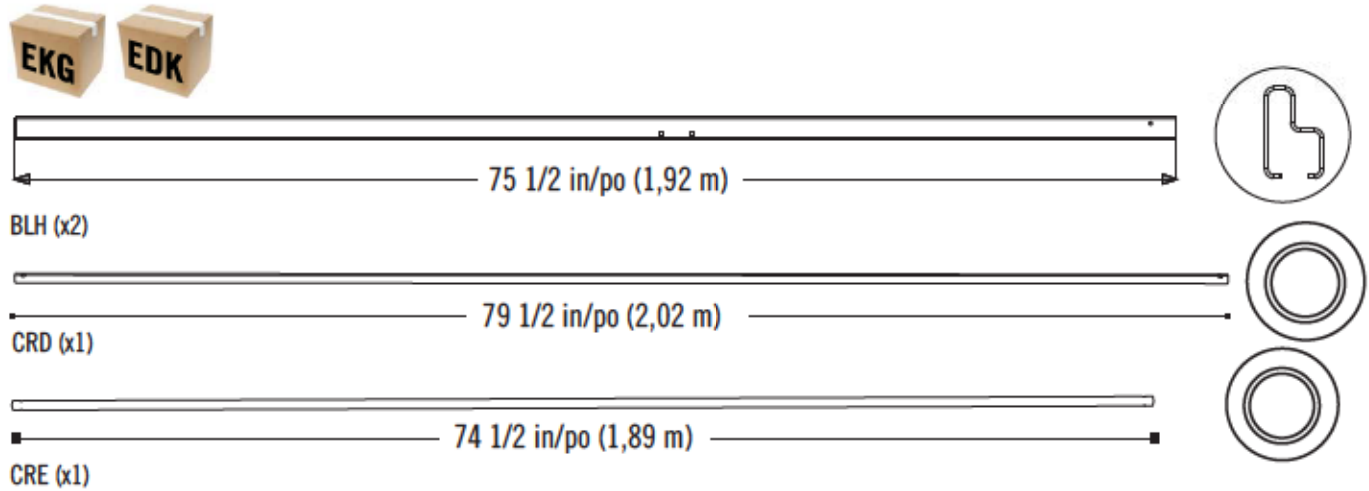

Plastic Parts / Pièces en plastique / Piezas de plástico



TOOLS REQUIRED / OUTILS REQUIS / INSTRUMENTAL REQUERIDO

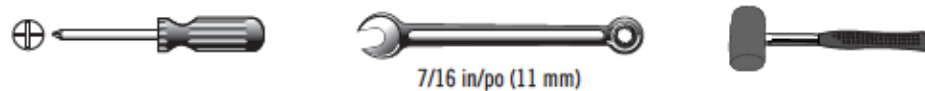

► SECTION 4 (CONTINUED) / SECTION 4 (SUITE) / SECCIÓN 4 (CONTINUACIÓN)

TOOLS AND PARTS REQUIRED / OUTILS ET QUINCAILLERIE REQUIS / INSTRUMENTAL Y HERRAJE REQUERIDOS



- If you have trouble with this section, follow the code below to view a how-to video on this section.
- En cas de problèmes avec cette section, suivre le code en bas pour voir un vidéo sur l'assemblage dans cette section.
- En caso de algun problema con esta sección, seguir el código debajo para ver un video sobre el ensamble en esta sección.



<http://go.lifetime.com/lidsidelatch>

4.1

- Slide a **Hinge Tube (CRD)** down into the hole at the top of the **Left Door (BDJ)**.
- Faire glisser le **tube d'articulation (CRD)** dans le trou au bord supérieur de la **porte gauche (BDJ)**.
- Deslizar el **tubo de articulación (CRD)** en el agujero a la parte superior de la **puerta izquierda (BDJ)**.

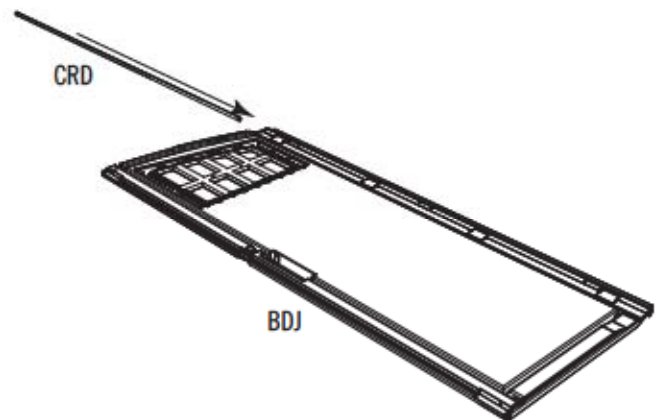

- **Door Channels (BLH)** are specifically designed to bow. This ensures a tight fit when they are closed and latched, making your shed more secure. These channels are formed with a slight bend to the adjoining door edge—like parentheses facing each other: (). When the door handle is gently closed and latched, there should be a slight pressure sealing the doors and eliminating any gaps. Be sure to read the step-by-step instructions carefully to successfully install the door channels.
- Les canaux pour le bord des portes (BLH) sont conçus spécifiquement avec une courbe. Cette courbe s'assure un ajustage lorsque les portes se ferment, en faisant votre abri plus sûr. Ces canaux sont fabriqués avec une légère courbe au bord de la porte adjacente — comme les parenthèses qui font face l'une l'autre : (). Lorsque la poignée se ferme, il devrait un légère pression en rebouchant les portes et en éliminant des ouvertures. Assurez-vous de lire avec soin les instructions étape par étape pour pouvoir installer avec succès les canaux pour le bord des portes.
- Los canales para el borde de las puertas (BLH) son diseñados específicamente con una curva. Esta curva asegure un ajuste fijo cuando las puertas estén cerrados con pestillo, haciendo su caseta más segura. Estos canales están formados con una curva ligera al borde de la puerta adyacente, como los paréntesis uno enfrente al otro: (). Cuando el picaporte esté ligeramente cerrado con pestillo, debería tener una presión ligera sellando las puertas y eliminando los espacios. Asegúrese de leer detenidamente las instrucciones paso a paso para poder instalar exitosamente los canales para el borde de las puertas.



BLH (x1)



► SECTION 4 (CONTINUED) / SECTION 4 (SUITE) / SECCIÓN 4 (CONTINUACIÓN)

TOOLS AND PARTS REQUIRED / OUTILS ET QUINCAILLERIE REQUIS / INSTRUMENTAL Y HERRAJE REQUERIDOS



AHM (x2)



BYR (x1)



BYS (x1)

4.2

- Set the **Deadbolts (AHM)** down into the recesses at the top and bottom of the Door. Then, slide the **Door End Channel (BLH)** over the edge of the Door and the bottom of the Deadbolts as shown.
- Mettre les **loquets à pêne dormant (AHM)** dans les espaces vides aux parties supérieure et inférieure de la porte. Ensuite, faire glisser le **canal de la porte (BLH)** sur le bord de la porte et les parties inférieures des loquets à pêne dormant comme illustré.
- Poner los **cerrojos (AHM)** en los huecos a las partes superior e inferior de la puerta. Entonces, deslizar el **canal para el borde de la puerta (BLH)** sobre el borde de la puerta y las partes inferiores de los cerrojos como se muestra.

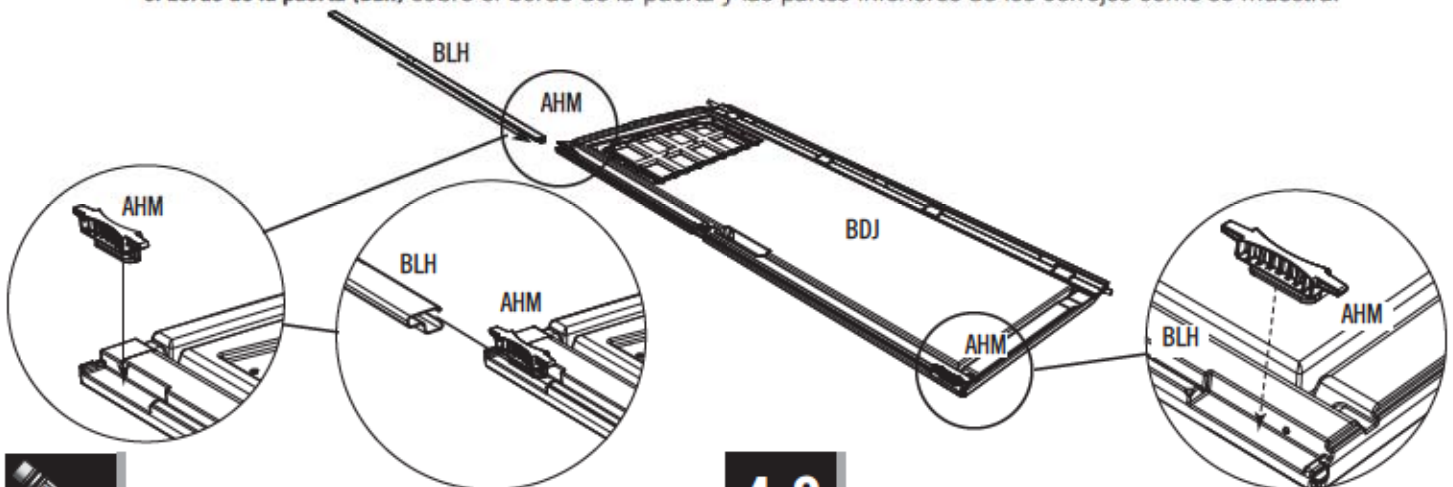

- *Note: The Deadbolts are used for locking the door. They may not move freely at first. You may need to tap them up and down a few times with a rubber mallet to work them in.*
- *Remarque : On utilise les loquets pour fermer la porte. Au début, il se peut que les loquets ne se déplaceraient librement. Vous devrez peut-être les taper légèrement à l'aide d'un maillet en caoutchouc pour les desserrer.*
- *Nota: Se usan los cerrojos para cerrar la puerta. Al principio, pueden que no se desplacen libremente. Puede que necesite darlos unos golpecitos con un mazo de goma para aflojarlos.*

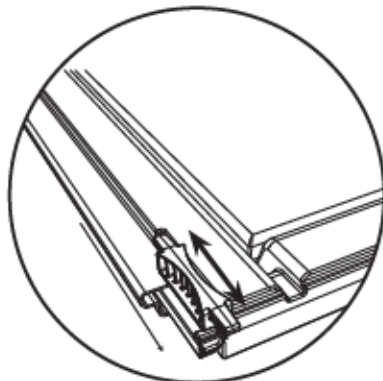

4.3

- Attach the two **Handle Pieces (BYR & BYS)** together as shown.
- Attacher les deux pièces de la **poignée (BYR et BYS)** comme illustré.
- Conectar las dos piezas del **picaporte (BYR y BYS)** como se muestra.

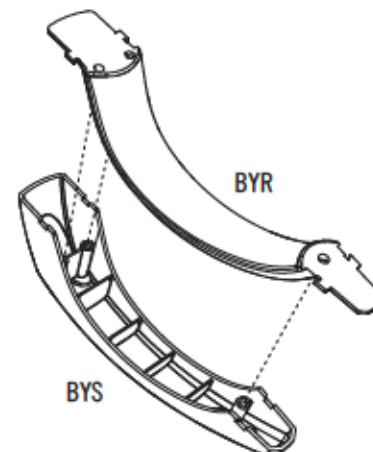

► SECTION 4 (CONTINUED) / SECTION 4 (SUITE) / SECCIÓN 4 (CONTINUACIÓN)

TOOLS AND PARTS REQUIRED / OUTILS ET QUINCAILLERIE REQUIS / INSTRUMENTAL Y HERRAJE REQUERIDOS



7/16 in/po
(11 mm)

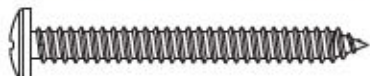

BYZ (x2)



ABU (x2)



ADW (x1)



AEE (x3)



AEB (x2)



ADJ (x2)



ECY (x1)



ECX (x1)

4.4

- Attach the Handle to the Door using the hardware included. **Do not overtighten.**
- Attacher la poignée à la porte à l'aide de la quincaillerie incluse. **Ne pas trop serrer.**
- Sujetar el picaporte a la puerta usando el herraje incluido. **No apretar demasiado.**

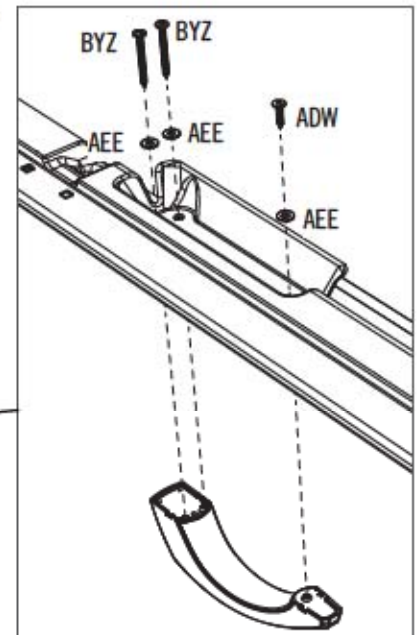

4.5

- Attach the **Strike Plate (ECX)** and **Lock Bracket (ECY)** to the Channel as shown. **Only hand-tighten the hardware for now.**
- Attacher la **gâche (ECX)** et la **plaque de verrouillage (ECY)** au canal comme illustré. **Serrer la quincaillerie à la main seulement en ce moment.**
- Sujetar la **placa de impacto (ECX)** y la **placa de cierre (ECY)** al canal como se muestra. **Apretar el herraje sólo a mano en este momento.**

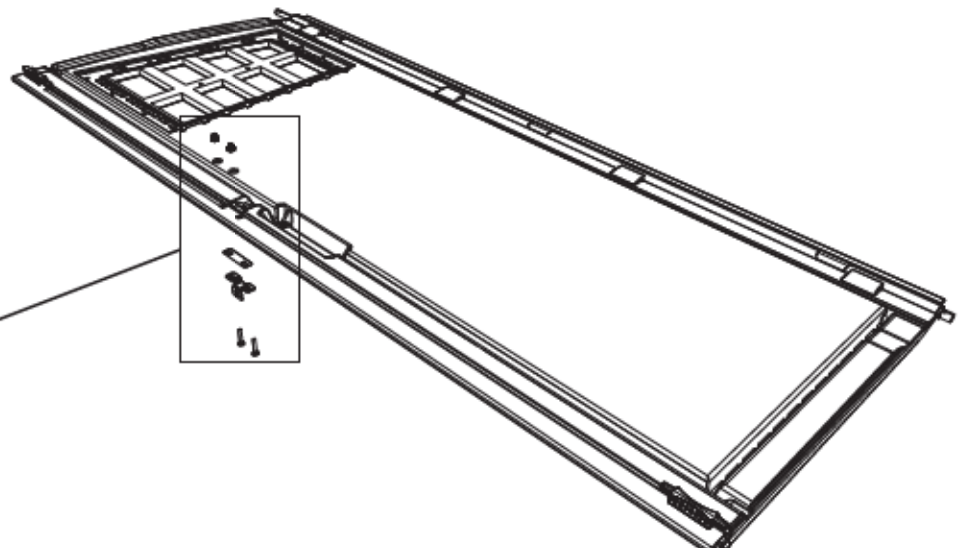
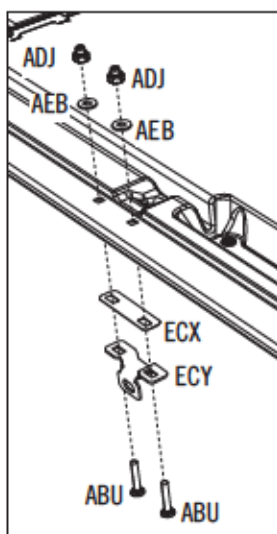

► SECTION 4 (CONTINUED) / SECTION 4 (SUITE) / SECCIÓN 4 (CONTINUACIÓN)

TOOLS AND PARTS REQUIRED / OUTILS ET QUINCAILLERIE REQUIS / INSTRUMENTAL Y HERRAJE REQUERIDOS

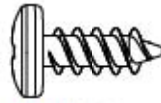

ADZ (x14)

4.6

- Align the holes in the Pane with those in the Door, and gently set a **Window Pane (DHN)** down onto the Door.
- Aligner les trous dans le carreau avec ceux de la porte, et, avec douceur, mettre le **carreau (DHN)** sur la porte.
- Alinear los agujeros en la hoja con los de la puerta, y colocar ligeramente la **hoja de ventana (DHN)** en la puerta.

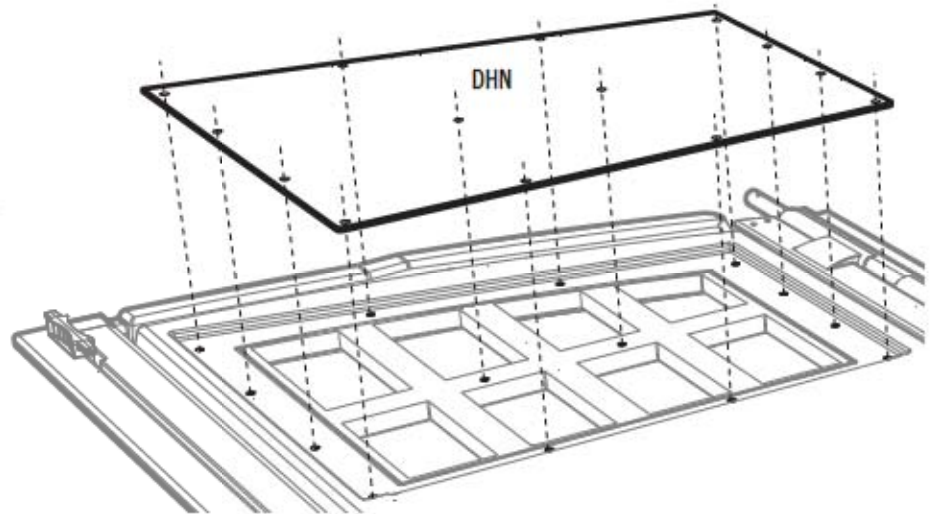
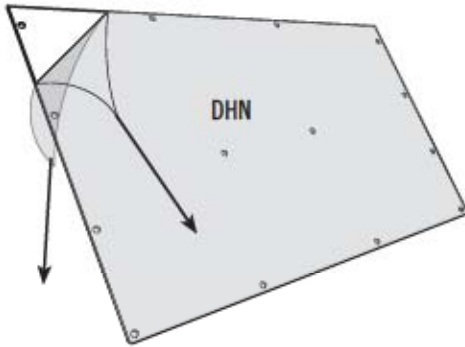

4.7

- Secure the Pane to the Door using fourteen (14) **Screws (ADZ)**.
- Fixer le carreau à la porte en utilisant quatorze (14) **vis (ADZ)**.
- Fijar la hoja a la puerta usando catorce (14) **tornillos (ADZ)**.

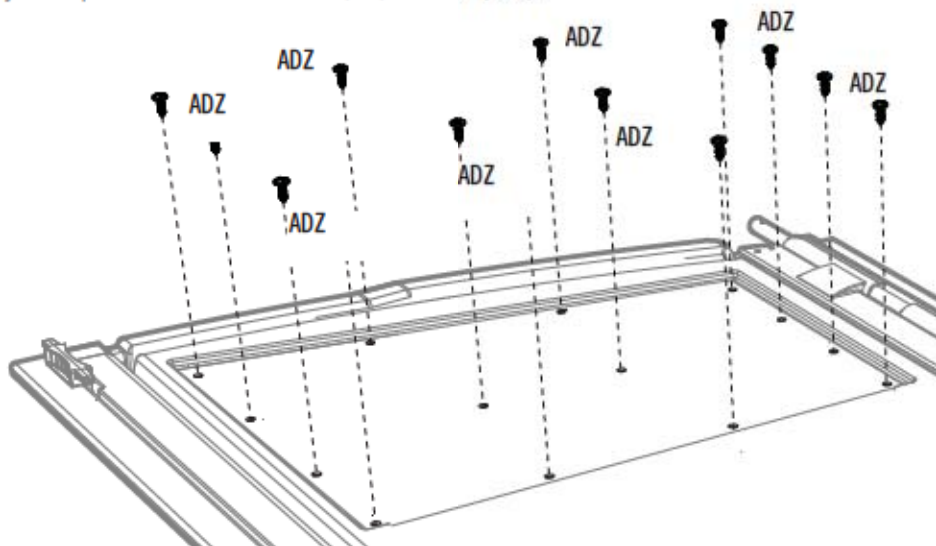

► SECTION 4 (CONTINUED) / SECTION 4 (SUITE) / SECCIÓN 4 (CONTINUACIÓN)

TOOLS AND PARTS REQUIRED / OUTILS ET QUINCAILLERIE REQUIS / INSTRUMENTAL Y HERRAJE REQUERIDOS

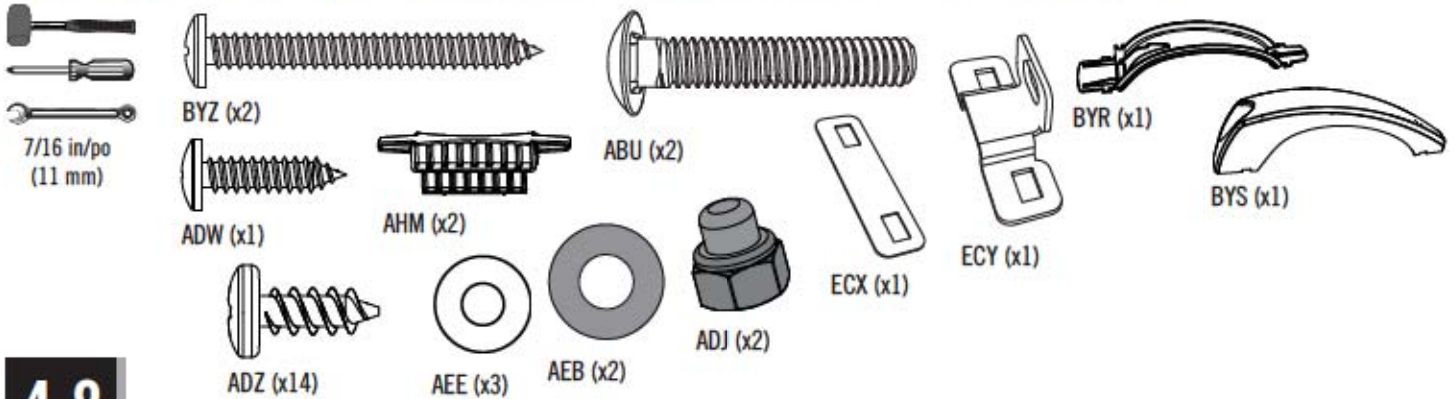

4.8

- Repeat the previous steps with these parts.
- Répéter les étapes précédentes à l'aide de ces pièces.
- Repetir los pasos anteriores con estas piezas.

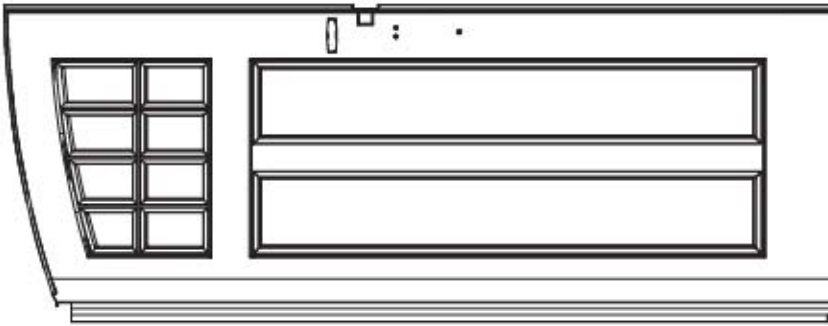

BDJ (x1)

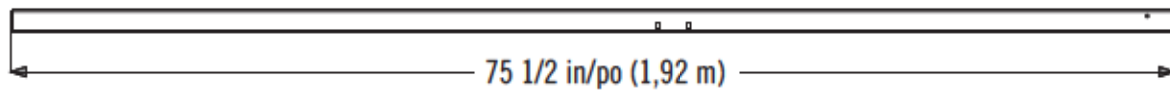

BLH (x1)

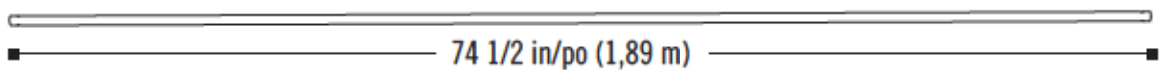

CRE (x1)



5

RIGHT DOOR ASSEMBLY / ASSEMBLAGE DE LA PORTE DROITE / ENSAMBLE DE LA PUERTA DERECHA



HARDWARE REQUIRED / QUINCAILLERIE REQUISE / HERRAJE REQUERIDO

Hardware Bag / Sac de quincaillerie / Bolsa de herraje



ADW (x2)



AEE (x2)



BYR (x2)



BYZ (x2)



AEB (x2)



BYZ (x4)



ADJ (x4)



ECZ (x2)



ECW (x2)

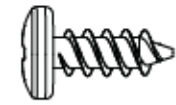

ADZ (x14)

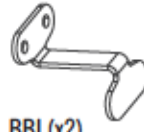

BBI (x2)



ABU (x4)

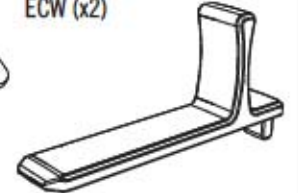

EDA (x2)



PARTS REQUIRED / PIÈCES REQUISES / PIEZAS REQUERIDAS

Metal Parts / Pièces en métal / Piezas de metal

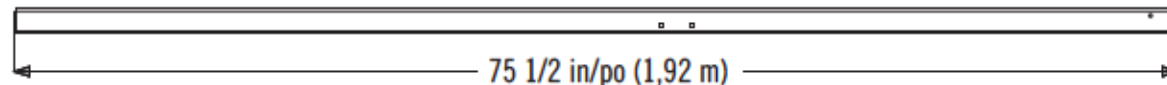

BLH (x2)

75 1/2 in/po (1,92 m)



CRD (x1)

79 1/2 in/po (2,02 m)



CRE (x1)

74 1/2 in/po (1,89 m)



Plastic Parts / Pièces en plastique / Piezas de plástico

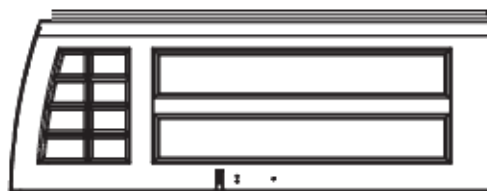

BDK (x2)

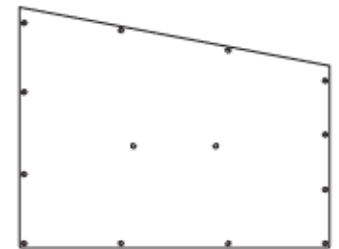

DHN (x2)



TOOLS REQUIRED / OUTILS REQUIS / INSTRUMENTAL REQUERIDO



7/16 in/po (11 mm)



► SECTION 5 (CONTINUED) / SECTION 5 (SUITE) / SECCIÓN 5 (CONTINUACIÓN)

TOOLS AND PARTS REQUIRED / OUTILS ET QUINCAILLERIE REQUIS / INSTRUMENTAL Y HERRAJE REQUERIDOS



BYR (x1)



BYB (x1)



- If you have trouble with this section, follow the code below to view a how-to video on this section.
- Si vous avez des problèmes avec cette section, suivez le code en bas pour voir un vidéo sur l'assemblage dans cette section.
- Si tiene problemas con esta sección, siga el código debajo para ver un video sobre el ensamble en esta sección.



<http://go.lifetime.com/rdsliidelatch>



- Door Channels (BLH) are bowed by design, ensuring a tight fit when they are closed and latched, making your shed more secure. These channels are formed with a slight bend to the adjoining door edge—like parentheses facing each other: (). When the door handle is gently closed and latched, there should be a slight pressure sealing the doors and eliminating any gaps. Be sure to read the step-by-step instructions carefully to successfully install the door channels.
- Les canaux pour le bord des portes (BLH) sont courbés par dessein, en s'assurant un ajustage lorsque les portes se ferment, en faisant votre abri plus sûr. Ces canaux sont fabriqués avec une légère courbe au bord de la porte adjacent — comme les parenthèses qui font face l'une l'autre : (). Lorsque la poignée se ferme, il devrait un légère pression en rebouchant les portes et en éliminant des ouvertures. Assurez-vous de lire avec soin les instructions étape par étape pour pouvoir installer avec succès les canaux pour le bord des portes.
- Los canales para el borde de las puertas (BLH) son curvados por diseño, asegurando un ajuste fijo cuando las puertas estén cerrados con pestillo, haciendo su caseta más segura. Estos canales están formados con una curva ligera al borde de la puerta adyacente, como los paréntesis uno enfrente al otro: (). Cuando el picaporte esté ligeramente cerrado con pestillo, debería tener una presión ligera sellando las puertas y eliminando los espacios. Asegúrese de leer detenidamente las instrucciones paso a paso para poder instalar exitosamente los canales para el borde de las puertas.

5.1

- Slide a Hinge Tube (CRD) down into the hole at the top of the Right Door (BDK).
- Faites glisser le tube d'articulation (CRD) dans le trou au bord supérieur de la porte droite (BDK).
- Deslice el tubo de articulación (CRD) en el agujero a la parte superior de la puerta derecha (BDK).

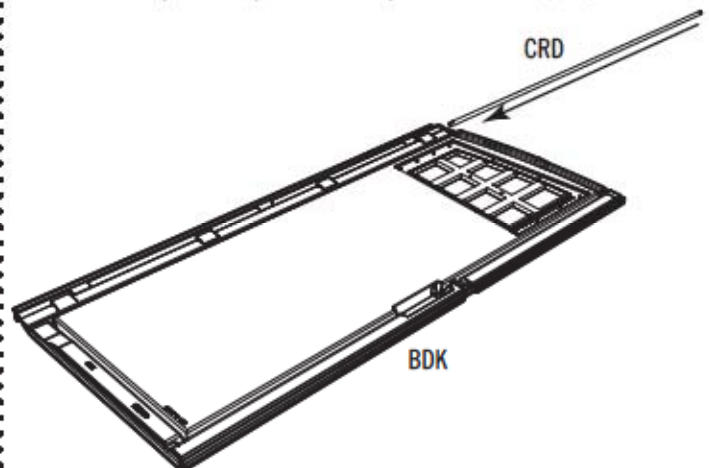

► SECTION 5 (CONTINUED) / SECTION 5 (SUITE) / SECCIÓN 5 (CONTINUACIÓN)

TOOLS AND PARTS REQUIRED / OUTILS ET QUINCAILLERIE REQUIS / INSTRUMENTAL Y HERRAJE REQUERIDOS

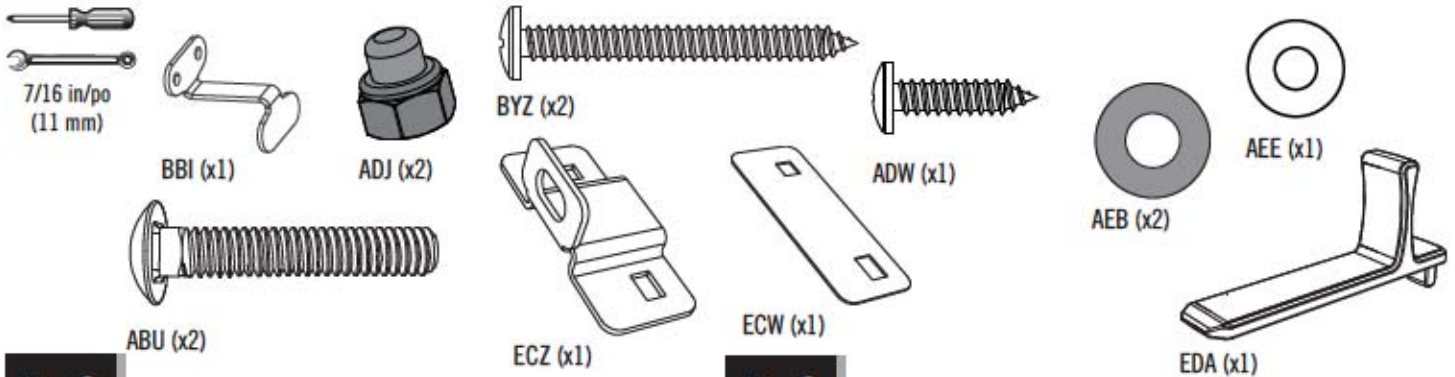

5.2

- Slide the **Door End Channel (BLH)** over the edge of the Door as shown.
- Deslice el **canal para el borde de la puerta (BLH)** sobre el borde de la puerta como se muestra.
- Faites glisser le **canal de la porte (BLH)** sur le bord de la porte comme illustré.

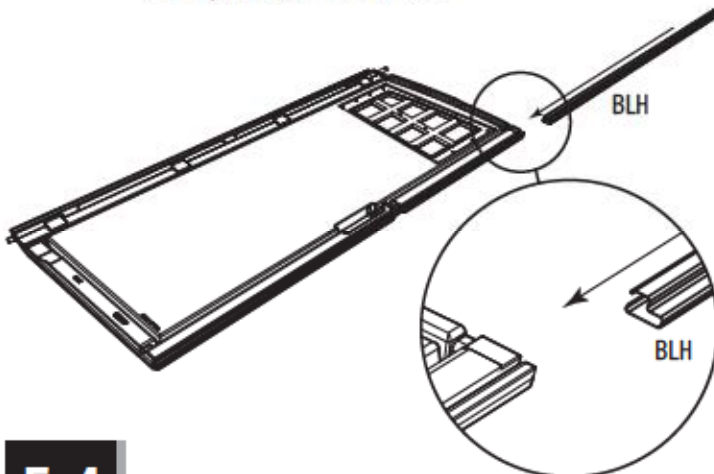

5.3

- Attach the two **Handle Pieces (BYR & BYS)** together as shown.
- Attachez les deux pièces de la **poignée (BYR et BYS)** comme illustré.
- Conecte las dos piezas del **picaporte (BYR y BYS)** como se muestra.

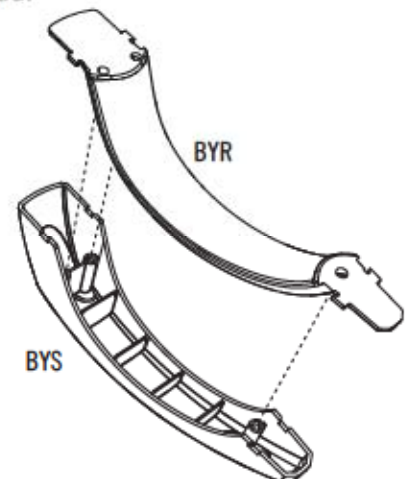

5.4

- Attach the Handle using the hardware included.
- Attachez la poignée à l'aide de la quincaillerie incluse.
- Sujete el picaporte usando el herraje incluido.

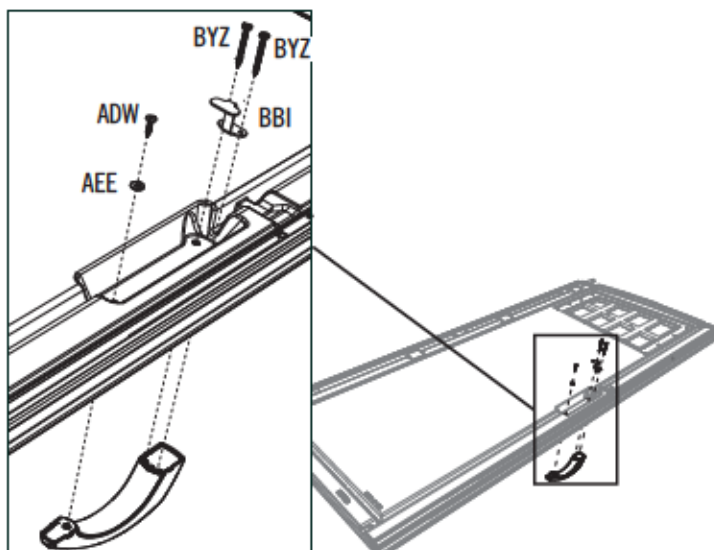

5.5

- Attach the Locking Hardware by hand only.
- N'attachez qu'à la main seulement la quincaillerie de verrouillage.
- Sujete los accesorios de cierre sólo a mano.

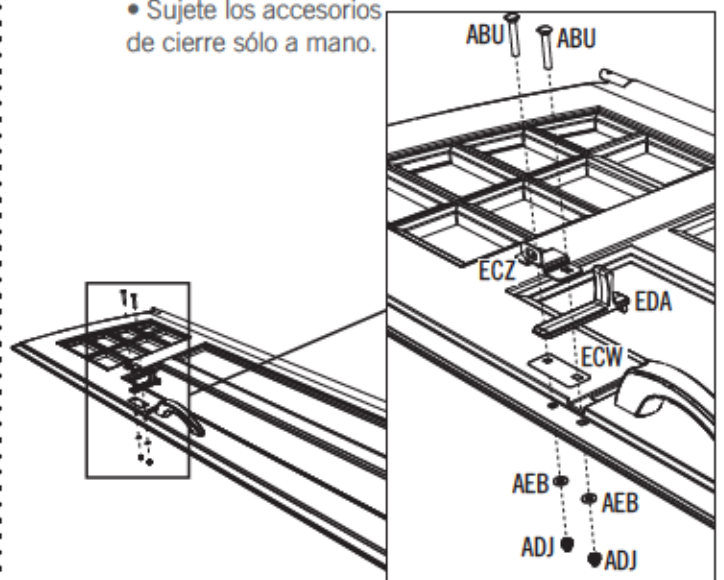

► SECTION 5 (CONTINUED) / SECTION 5 (SUITE) / SECCIÓN 5 (CONTINUACIÓN)

TOOLS AND PARTS REQUIRED / OUTILS ET QUINCAILLERIE REQUIS / INSTRUMENTAL Y HERRAJE REQUERIDOS

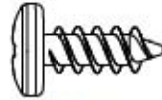

ADZ (x14)

5.6

- Align the holes in the Pane with those in the Door, and gently set a **Window Pane (DHN)** down onto the Door.
- Alignez les trous dans le carreau avec ceux de la porte, et, avec douceur, mettez le **carreau (DHN)** sur la porte.
- Alinee los agujeros en la hoja con los de la puerta, y coloque ligeramente la **hoja de ventana (DHN)** en la puerta.

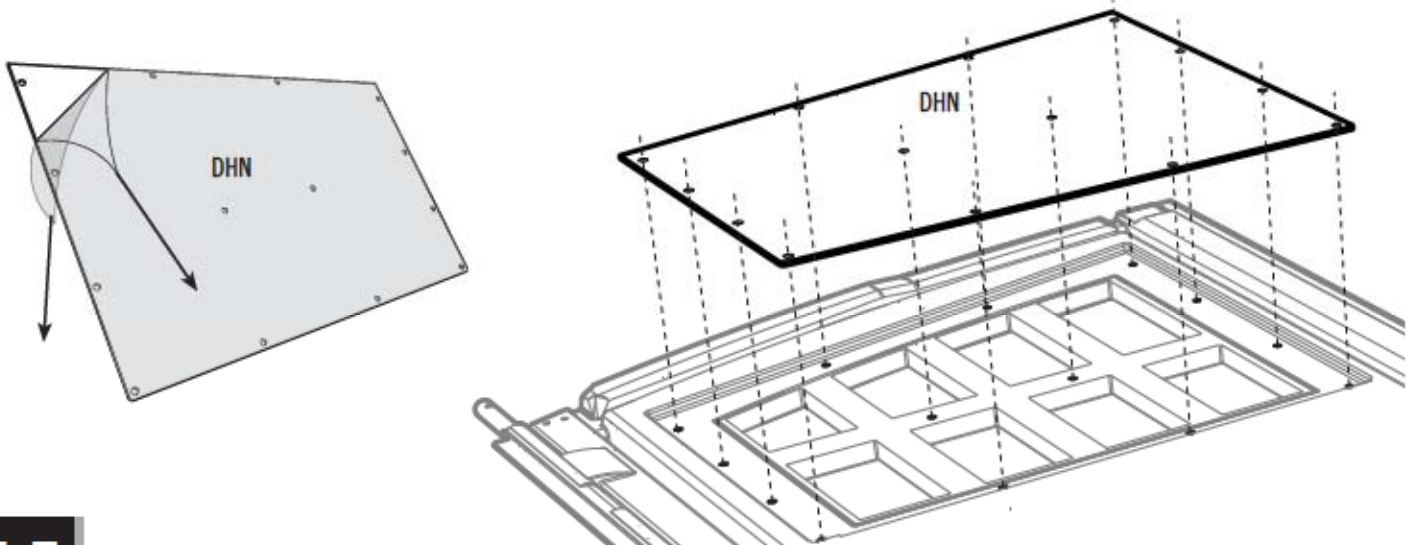

5.7

- Secure the Pane to the Door using fourteen (14) **Screws (ADZ)**.
- Fixez le carreau à la porte en utilisant quatorze (14) **vis (ADZ)**.
- Sujete la hoja a la puerta usando catorce (14) **tornillos (ADZ)**.

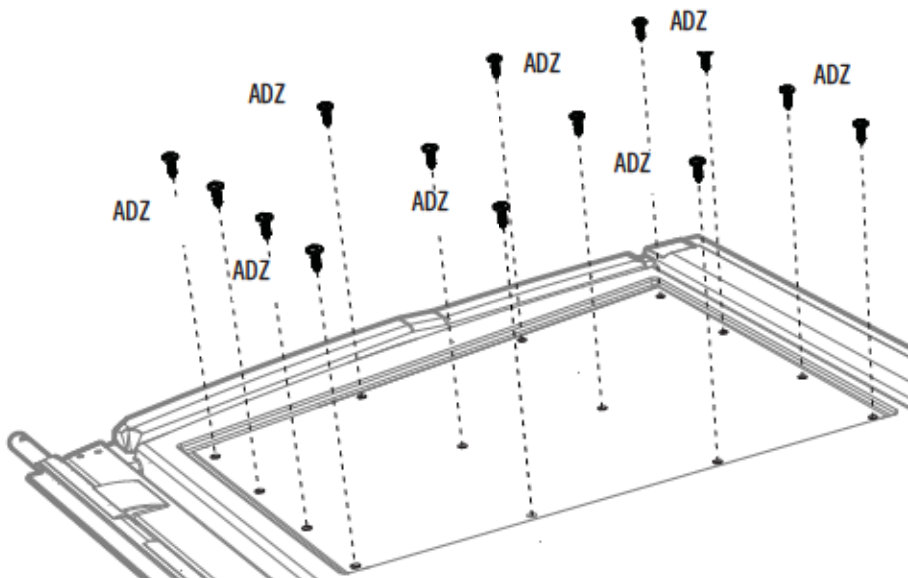

► SECTION 5 (CONTINUED) / SECTION 5 (SUITE) / SECCIÓN 5 (CONTINUACIÓN)

TOOLS AND PARTS REQUIRED / OUTILS ET QUINCAILLERIE REQUIS / INSTRUMENTAL Y HERRAJE REQUERIDOS

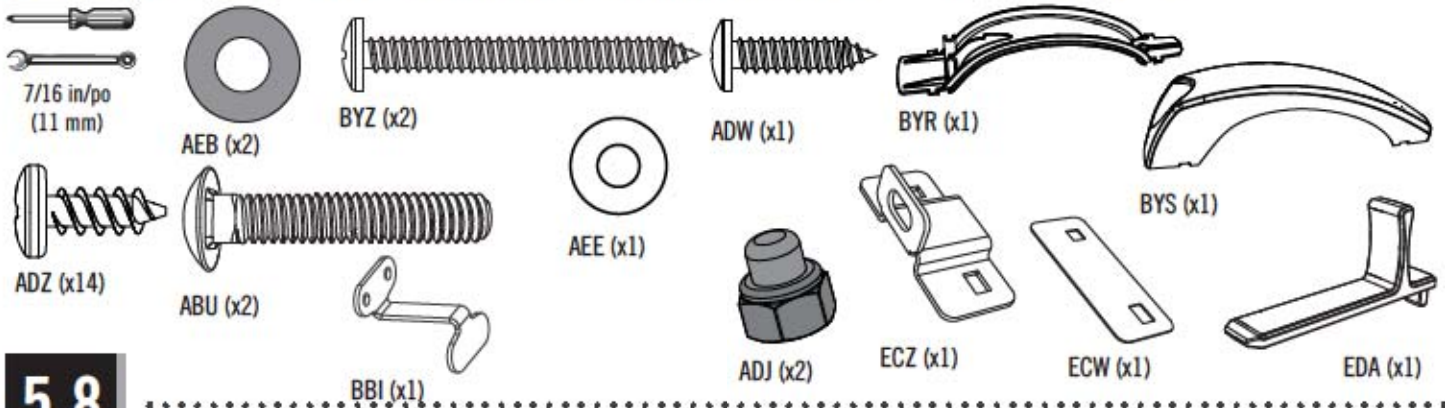

5.8

- Repeat the previous steps with these parts.
- Répétez les étapes précédentes à l'aide de ces pièces.
- Repita los pasos anteriores con estas piezas.

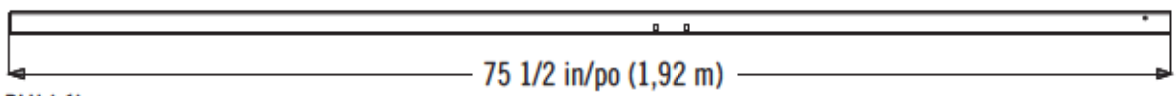
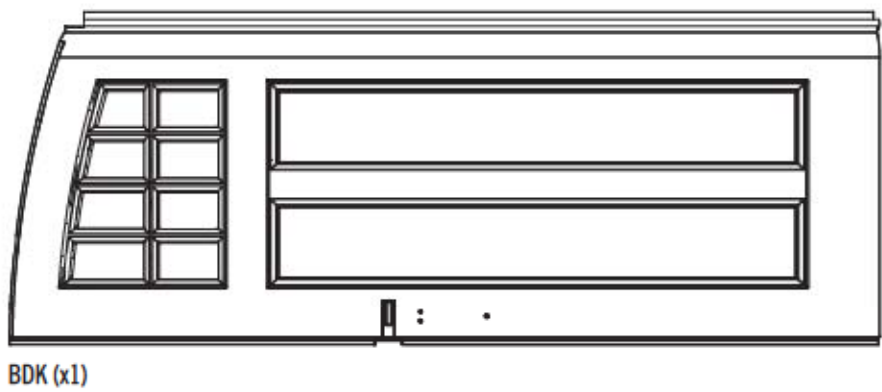

BLH (x1)

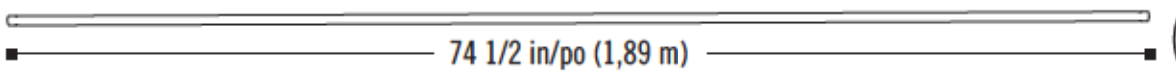

CRE (x1)



6

DOMED SKYLIGHT ASSEMBLY / ASSEMBLAGE DES LUCARNES EN FORME DE DÔME / ENSEMBLE DE LOS TRAGALUCES EN FORMA DE CÚPULA



HARDWARE REQUIRED / QUINCAILLERIE REQUISE / HERRAJE REQUERIDO

Hardware Bag / Sac de quincaillerie / Bolsa de herraje



EFA (x24)



ADK (x24)



AEE (x48)



AHI (x2)



PARTS REQUIRED / PIÈCES REQUISES / PIEZAS REQUERIDAS

Plastic Parts / Pièces en plastique / Piezas de plástico

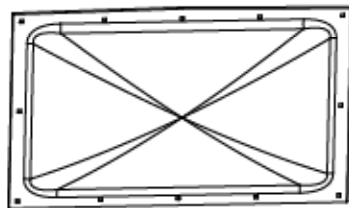

AGB (x2)

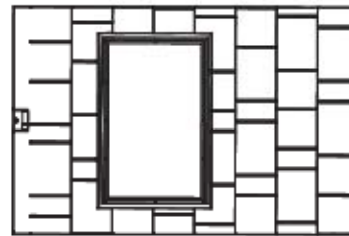

AHB (x2)



TOOLS REQUIRED / OUTILS REQUIS / INSTRUMENTAL REQUERIDO



3/8 in/po (10 mm)

► SECTION 6 (CONTINUED) / SECTION 6 (SUITE) / SECCIÓN 6 (CONTINUACIÓN)

TOOLS AND HARDWARE REQUIRED / OUTILS ET QUINCAILLERIE REQUIS / INSTRUMENTAL Y HERRAJE REQUERIDOS



AHI (x2)



• If you have trouble with this section, follow the code below to view a video on the assembly in this section.

• En cas d'avoir des problèmes avec cette section, suivre le code en bas pour voir un vidéo sur l'assemblage dans cette section.

• En caso de algún problema con esta sección, seguir el código debajo para ver un video sobre el ensamble en esta sección.



<http://go.lifetime.com/domedskylight>

6.1

- Remove any excess plastic from the holes.
- Enlever de l'excès de plastique des trous.
- Retirar cualquier plástico en exceso de los agujeros.

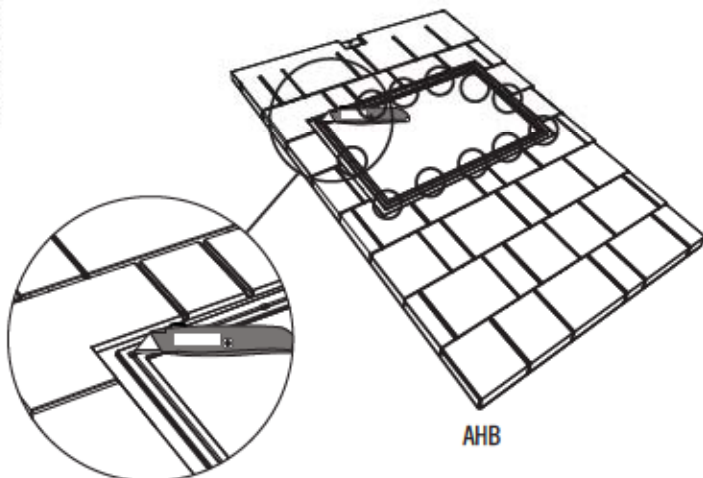

6.2

• Lay the **Butyl Tape (AHI)** over the groove along the top edge of the opening in the Roof Panel, and cut it. Peel back the paper backing a bit, and continue laying the Butyl Tape along the groove being sure to slightly overlap the ends. Continue this process until the groove around the opening is covered.

• Mettre le **ruban butyl (AHI)** sur la rainure le long du bord supérieur de l'ouverture du panneau de toit, et couper-le. Retirer un peu le papier de protection, et continuer de mettre le ruban butyl le long de la rainure. Continuer ce processus jusqu'à ce que la rainure autour de l'ouverture soit couverte.

• Colocar la **cinta butílica (AHI)** sobre la ranura a lo largo del borde superior de la abertura del panel de techo, y cortarla. Retirar el papel protector un poco, y continuar colocar la cinta butílica a lo largo de la ranura, asegurando de solaparse los extremos. Continuar este proceso hasta que se cubra la ranura alrededor la abertura.

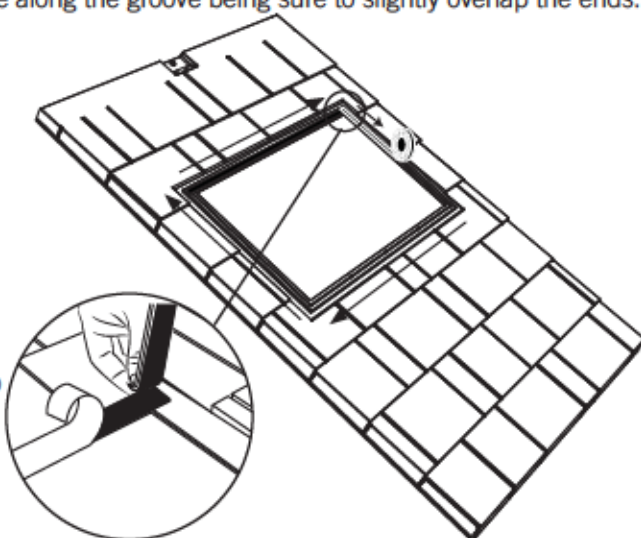

► SECTION 6 (CONTINUED) / SECTION 6 (SUITE) / SECCIÓN 6 (CONTINUACIÓN)

TOOLS AND HARDWARE REQUIRED / OUTILS ET QUINCAILLERIE REQUIS / INSTRUMENTAL Y HERRAJE REQUERIDOS



6.3

- Run your thumb along the Butyl Tape to remove any bubbles. Then, completely remove the paper backing.
- Mettre la pouce le long du ruban butylique pour éliminer des bulles. Ensuite, retirer complètement le papier de protection.
- Con el pulgar, presionar a lo largo de la cinta butílica para eliminar cualquier burbuja. Entonces, retirar por completo el papel protector.

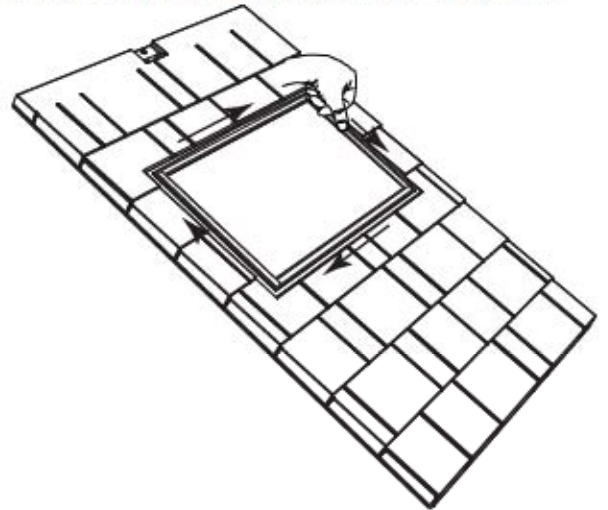

6.4

- Using a plain screwdriver, poke holes through the Butyl Tape and through the holes in the Roof Panel.
- Mettre un tournevis plat dans le ruban butylique et à travers les trous carrés dans le panneau de toit.
- Meter un destornillador de punta plana a través de la cinta butilo y los agujeros cuadrados en el panel de tejado.

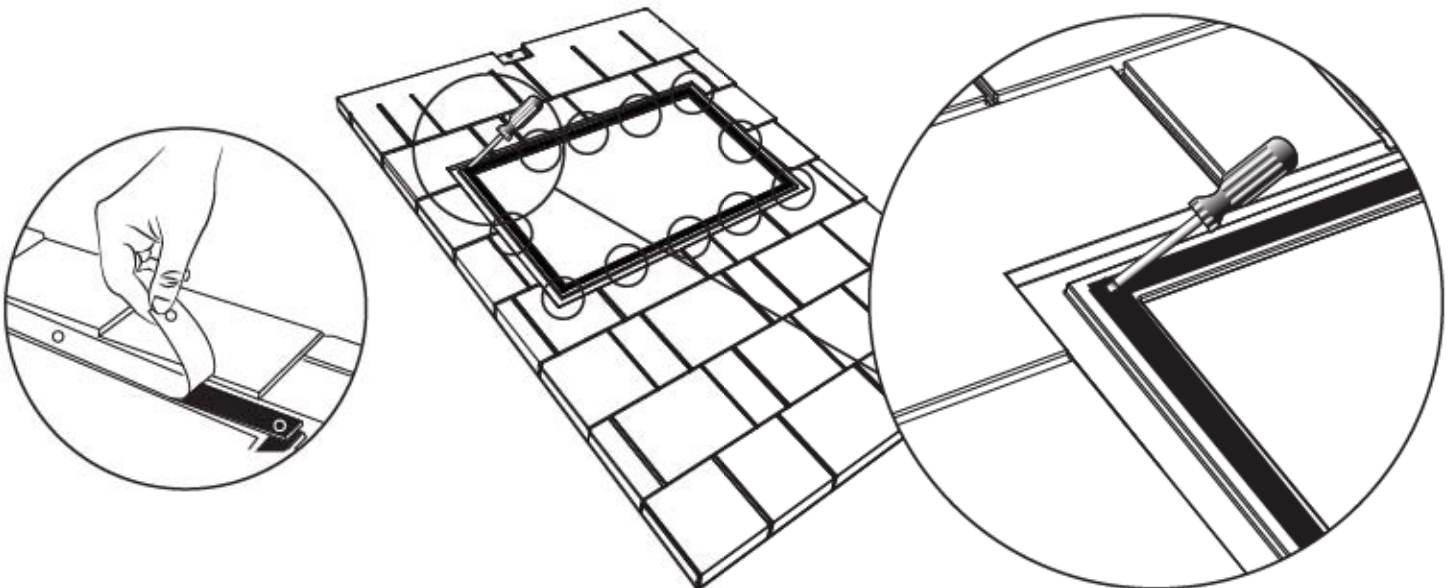

► SECTION 6 (CONTINUED) / SECTION 6 (SUITE) / SECCIÓN 6 (CONTINUACIÓN)

TOOLS AND HARDWARE REQUIRED / OUTILS ET QUINCAILLERIE REQUIS / INSTRUMENTAL Y HERRAJE REQUERIDOS



3/8 in/po
(10 mm)



EFA (x24)



ADK (x24)



AEE (x48)

6.5

- Remove the protective plastic from both sides of the **Skylight (AGB)**. Align the holes in the Domed Skylight with those in the Roof Panel, and insert the **Screws (EFA)**.
- Retirer la pellicule protectrice des deux côtés de la **lucarne (AGB)**. Aligner les trous dans la lucarne avec ceux du panneau de toit, et insérer les **vis (EFA)**.
- Retirar el protector de plástico de las dos caras del **tragaluz (AGB)**. Alinear los agujeros en el tragaluz con los del panel de tejado, e insertar los **tornillos (EFA)**.

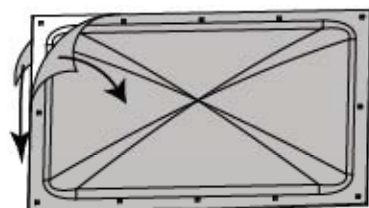

AGB

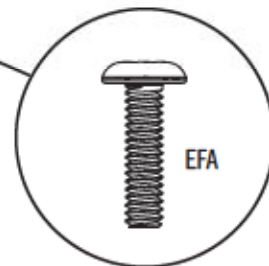
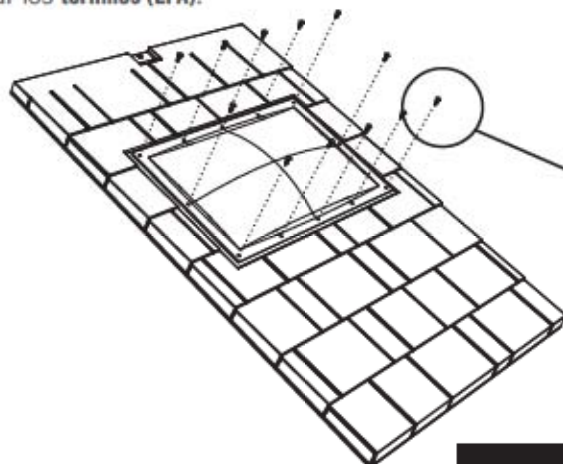

EFA

6.6

- Secure the Skylight using the hardware provided. **Do not overtighten.**
- Attacher bien la lucarne à l'aide de la quincaillerie incluse. **Ne pas trop serrer.**
- Sujetar el tragaluz usando el herraje incluido. **No apretar demasiado.**

6.7

- Repeat this section for the second Skylight.
- Répéter cette section pour la deuxième lucarne.
- Repetir esta sección para el segundo

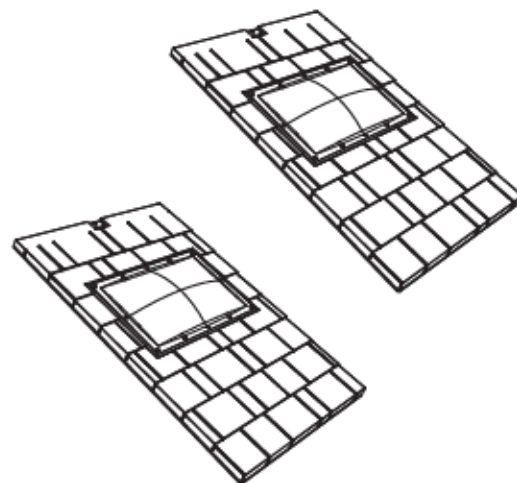
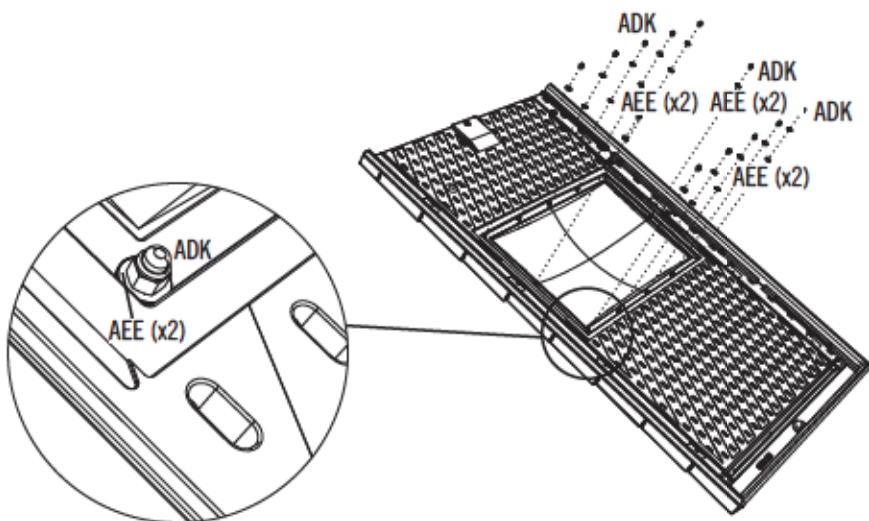

7

FLOOR ASSEMBLY / ASSEMBLAGE DU PLANCHER / ENSAMBLE DEL PISO



HARDWARE REQUIRED / QUINCAILLERIE REQUISE / HERRAJE REQUERIDO

Hardware Bags / Sacs de quincaillerie / Bolsas de herraje



BQC (x48)



AHO (x4)

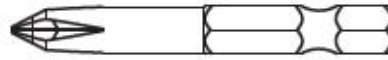

ADC (x2)



*Note: These are not anchoring screws. Their purpose is to fasten together the Floor Panels.
 Nota: Estos no son Tornillos de anclaje. Son propósito es sólo para unir los Paneles de piso.
 Note : Ces Vis ne sont pas de vis d'ancrage. Leur but est pour attacher les Panneaux de plancher.*



PARTS REQUIRED / PIÈCES REQUISES / PIEZAS REQUERIDAS

Plastic Parts / Pièces en plastique / Piezas de plástico

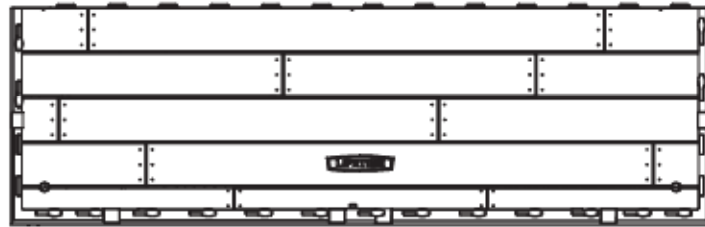

CUW (x2)

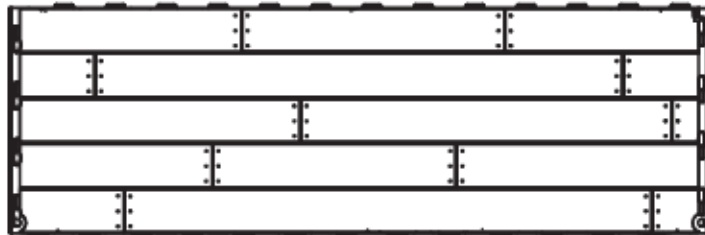

CUD (x6)



TOOLS REQUIRED / OUTILS REQUIS / INSTRUMENTAL REQUERIDO



► SECTION 7 (CONTINUED) / SECTION 7 (SUITE) / SECCIÓN 7 (CONTINUACIÓN)

TOOLS AND PARTS REQUIRED / OUTILS ET QUINCAILLERIE REQUIS / INSTRUMENTAL Y HERRAJE REQUERIDOS



7.1



- Hold an **Inner Floor Panel (CUD)** at an angle and slide the tabs along the edge underneath an **Outer Floor Panel (CUW)**. The tabs interlock. Lay Panel down flat.
- Posez un **panneau de plancher intérieur (CUD)** à un angle et glissez les languettes le long du bord au-dessus du **panneau de plancher extérieur (CUW)**. Les languettes s'enclenchent les uns les autres. Étendez-le par terre.
- Coloque un **panel de piso interior (CUD)** a un ángulo y deslice las lengüetas a lo largo del borde debajo el **panel de piso exterior (CUW)**. Las lengüetas se entrelazan las unas con las otras. Aplánelo.

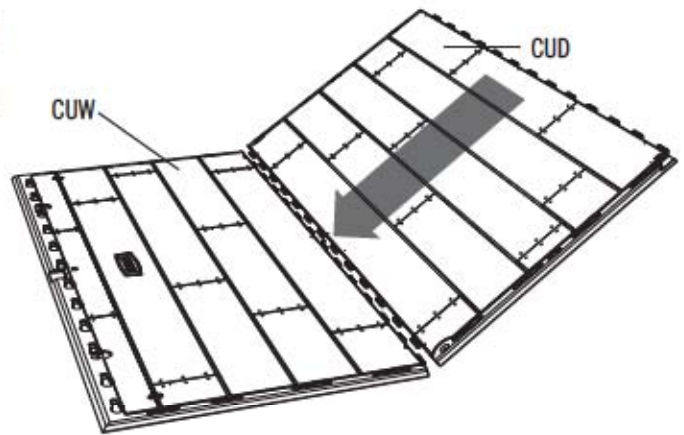

7.2

- Repeat the last step.
- Répétez l'étape précédente.
- Repita el paso anterior.

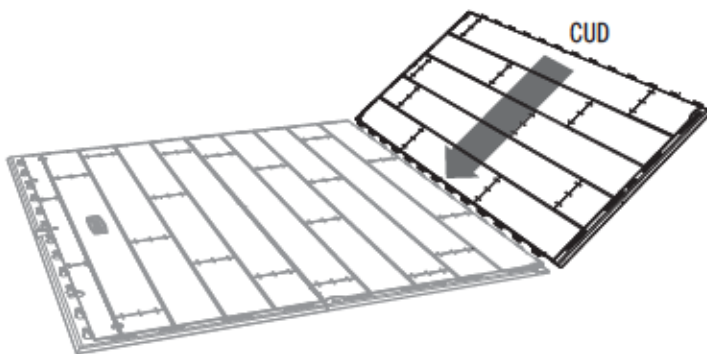

7.3

- Repeat the last step. If the hole is not at this corner, turn the Panel 180°.
- Répétez la dernière étape. Si le trou n'est pas ici, tournez le panneau 180°.
- Repita el último paso. Si el agujero no está aquí, gire el panel 180°.

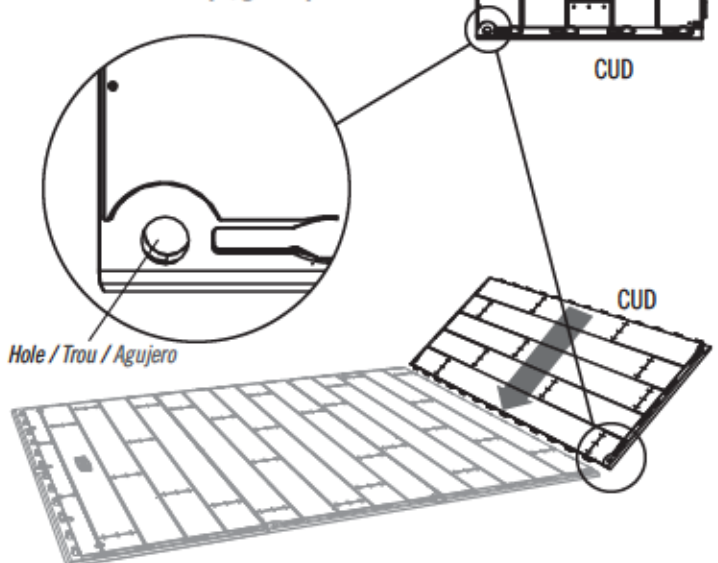

► SECTION 7 (CONTINUED) / SECTION 7 (SUITE) / SECCIÓN 7 (CONTINUACIÓN)

TOOLS AND PARTS REQUIRED / OUTILS ET QUINCAILLERIE REQUIS / INSTRUMENTAL Y HERRAJE REQUERIDOS



7.4



- Repeat the last step. If the hole is not at this corner, turn the Panel 180°.
- Répétez la dernière étape. Si le trou n'est pas ici, tournez le panneau 180°.
- Repita el último paso. Si el agujero no está aquí, gire el panel 180°.



Hole / Trou / Agujero

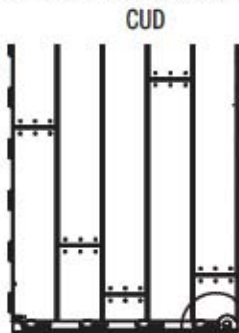

7.5



- Repeat step 7.2.
- Répétez l'étape 7.2.
- Repita el paso 7.2.

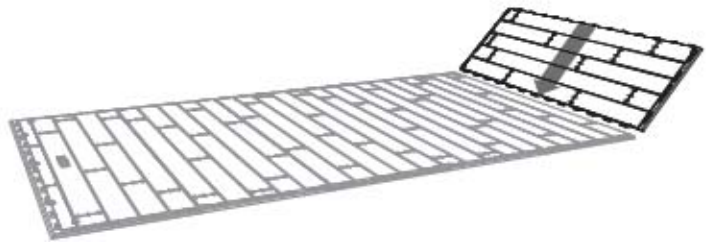

7.6

- Repeat the last step.
- Répétez l'étape précédente.
- Repita el paso anterior.

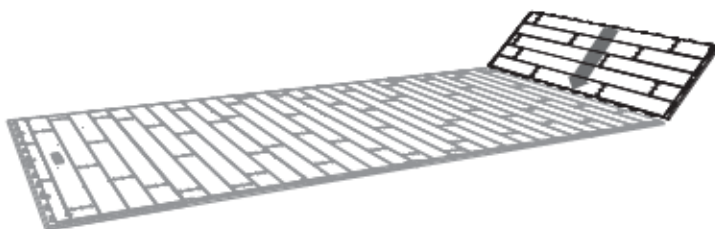

7.7

- Attach an **Outer Floor Panel (CUW)** to the Inner Floor Panel.
- Attachez un autre **panneau de plancher intérieur (CUW)** au panneau de plancher intérieur.
- Fije otro **panel de piso exterior (CUW)** al panel de piso interior.

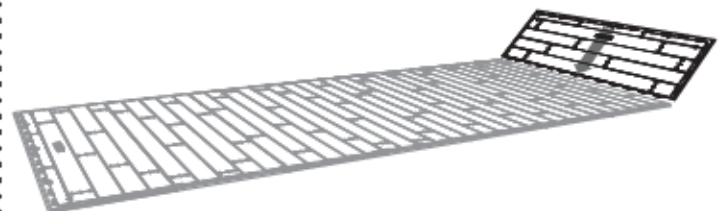

► SECTION 7 (CONTINUED) / SECTION 7 (SUITE) / SECCIÓN 7 (CONTINUACIÓN)

TOOLS AND PARTS REQUIRED / OUTILS ET QUINCAILLERIE REQUIS / INSTRUMENTAL Y HERRAJE REQUERIDOS



AHO (x4)

7.8

- Decide on which ends you would like to install your Doors (we placed the Doors on the front and the left side; however, you may install them on the front and on the left or right side of the shed). Insert **Bushings (AHO)** through the holes in the Floor. **The slit in the Bushing should face away from the Floor.**
- Choisissez les bords où vous désirez installer les portes (nous avons mettons les portes sur le bord avant et le bord gauche; néanmoins, vous pouvez les installer sur le bord avant et sur le bord gauche ou droit). Insérez les **bagues (AHO)** à travers les trous dans le plancher. **La fente dans la bague ne doit pas faire face au plancher.**
- Escoja los bordes en los cuales le gustaría instalar las puertas (nosotros coloquemos las puertas en el borde delantero y el borde izquierdo; sin embargo, se pueden instalarlas en la parte delantera y en la parte izquierda o derecha). Introduzca los **casquillos (AHO)** a través de los agujeros en el piso. **La rendija en el casquillo debe quedar en posición opuesta del piso.**

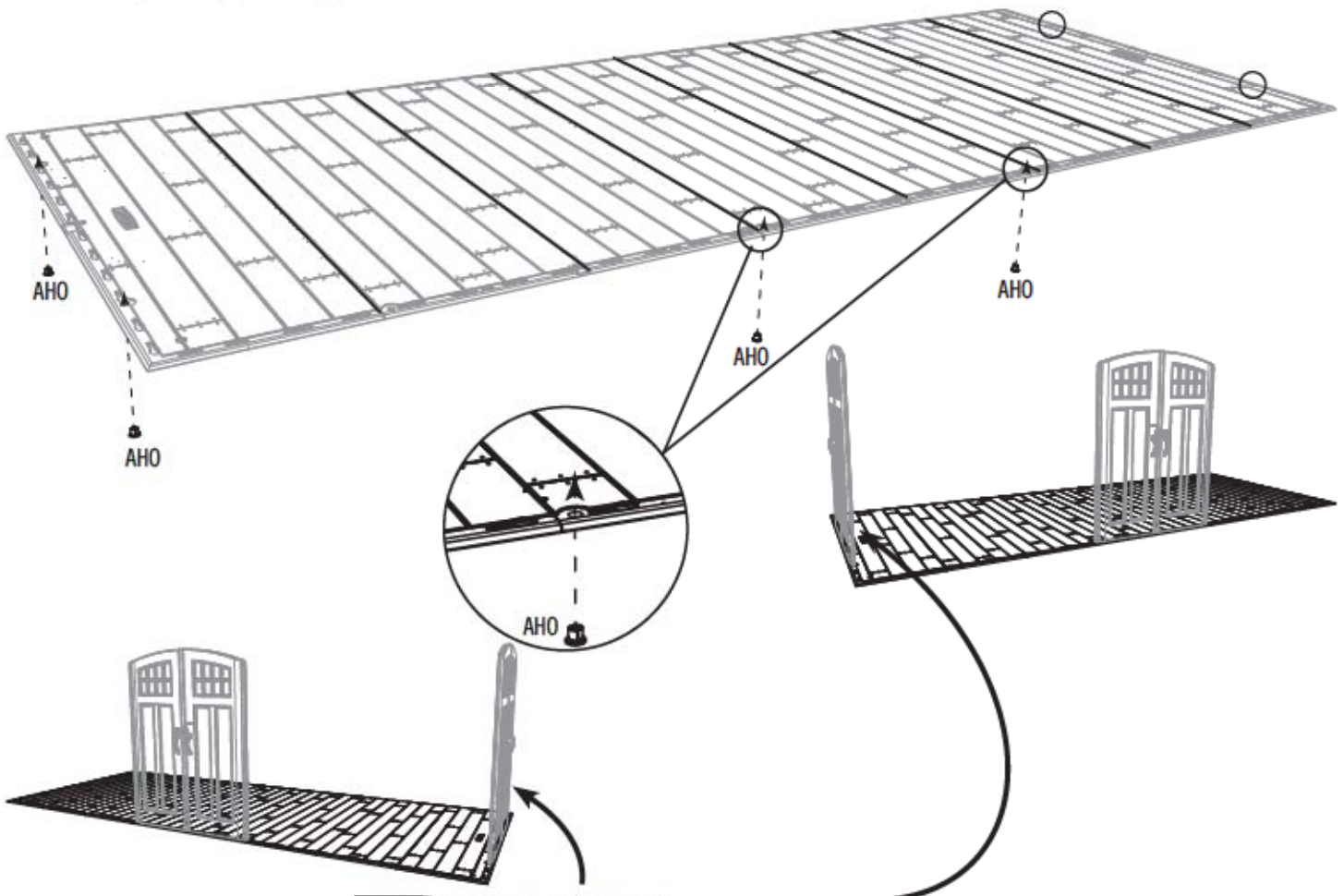

Note: These Doors may be placed on either end.

Remarque : Vous pouvez installer ces portes dans l'extrémité droite ou gauche.

Nota: Se pueden instalar estas puertas en el extremo derecho o izquierdo.

► SECTION 7 (CONTINUED) / SECTION 7 (SUITE) / SECCIÓN 7 (CONTINUACIÓN)

TOOLS AND PARTS REQUIRED / OUTILS ET QUINCAILLERIE REQUIS / INSTRUMENTAL Y HERRAJE REQUERIDOS



BQC (x42)

7.9

- Insert the **Screws (BQC)** through the divots in the Floor Panels and into the tabs of the adjacent Floor Panels. (The divots are near the seams of the Floor Panels.)
- Insérez les **vis (BQC)** à travers les marques dans les panneaux de plancher et dans les languettes du panneaux de plancher contigu. (Les marques se trouvent près des jonctions des panneaux de plancher.)
- Introduzca los **tornillos (BQC)** a través de las marcas en los paneles de piso y dentro de las lengüetas de los paneles de piso adyacentes. (Se encuentran las marcas cerca de las juntas de los paneles de piso.)



Note: These are not anchoring screws. Their purpose is to fasten together the Floor Panels.

Remarque : Ces vis ne sont pas de vis d'ancrage. Leur but est pour attacher les panneaux de plancher.

Nota: Estos no son tornillos de anclaje. Son propósito es sólo para unir los paneles de piso.

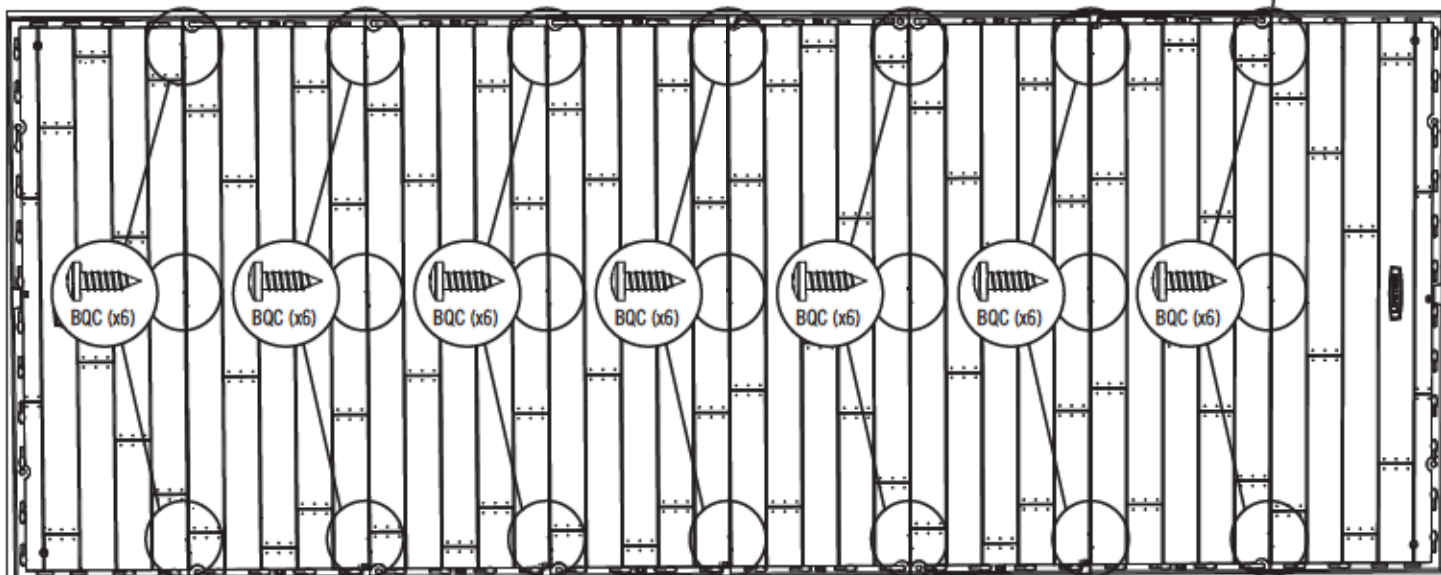
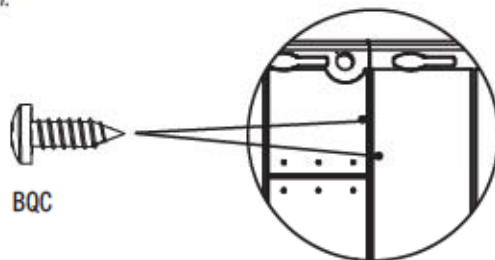

8

WALL ASSEMBLY / ASSEMBLAGE DES MURS / ENSAMBLE DE LOS MUROS



HARDWARE REQUIRED / QUINCAILLERIE REQUISE / HERRAJE REQUERIDO

Hardware Bag / Sac de quincaillerie / Bolsa de herraje

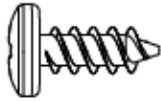

ADZ (x160)



PARTS REQUIRED / PIÈCES REQUISES / PIEZAS REQUERIDAS

Metal Parts / Pièces en métal / Piezas de metal

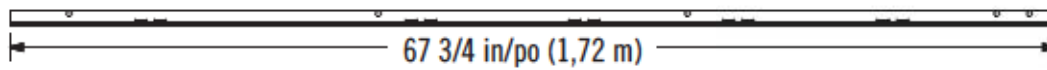

AFM (x17)



Plastic Parts / Pièces en plastique / Piezas de plástico

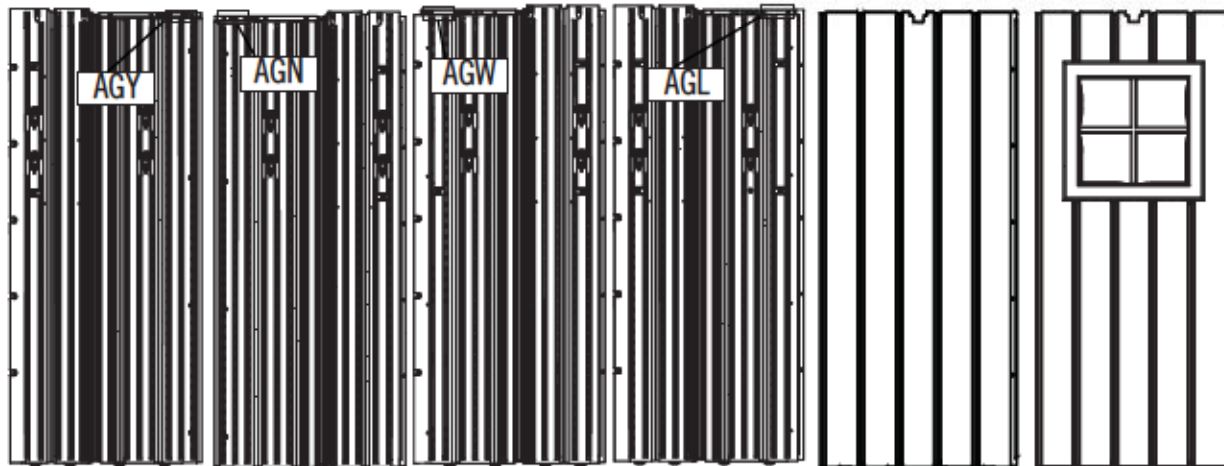

AGY (x1)

AGN (x1)

AGW (x1)

AGL (x1)

AHD (x11)

AHH (x2)



CKK (x1)



CKN (x1)



TOOLS REQUIRED / OUTILS REQUIS / INSTRUMENTAL REQUERIDO



AIW (x1)



► SECTION 8 (CONTINUED) / SECTION 8 (SUITE) / SECCIÓN 8 (CONTINUACIÓN)

TOOLS AND PARTS REQUIRED / OUTILS ET QUINCAILLERIE REQUIS / INSTRUMENTAL Y HERRAJE REQUERIDOS

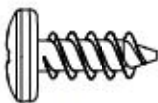

ADZ (x56)



• If you have trouble with this section, follow the code below to view a how-to video on this section.

• Si vous avez des problèmes avec cette section, suivez le code en bas pour voir un vidéo sur l'assemblage dans cette section.

• Si tiene problemas con esta sección, siga el código debajo para ver un video sobre el ensamble en esta sección.



<http://go.lifetime.com/20x8fwertwall>

8.1

• Secure a **Wall Support Channel (AFM)** to the center groove of each of the fourteen (14) **Wall Panels (AHD)** using four (4) **Screws (ADZ)** for each.

• Attachez un **canal de support (AFM)** à la rainure centrale de chaque des quatorze (14) **panneaux muraux (AHD)** à l'aide de quatre (4) **vis (ADZ)** chaque un.

• Sujete un **canal de soporte (AFM)** a la ranura central de cada de los catorce (14) **paneles murales (AHD)** usando cuatro (4) **tornillos (ADZ)** cada uno.

• Top End
• Extremo superior
• Extrémité supérieure



• No Screw in top hole.
• Aucune vis dans le trou supérieur.
• Ningún tornillo en el agujero superior.

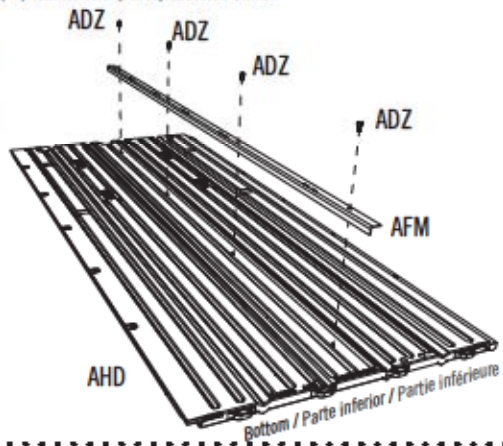

8.2

• Each **Corner Wall Panel** has a three-letter ID, **AGL, AGN, AGW, or AGY**, located near the top edge of the Panel.

• Chaque **panneau mural angulaire** possède une ID de trois lettres, **AGL, AGN, AGW, ou AGY**, qui est située le long du bord supérieur du panneau.

• Cada **panel mural angular** tiene una ID de tres letras, **AGL, AGN, AGW, o AGY**, ubicada a lo largo del borde superior del panel.

• Secure a **Wall Support Channel (AFM)** to the **Corner Wall Panels (AGW and AGY)** using four (4) **Screws (ADZ)**. **The end with two holes goes at the bottom.**

• Attachez un **canal de support (AFM)** aux **panneaux muraux (AGW et AGY)** à l'aide de quatre (4) **vis (ADZ)**. **L'extrémité avec deux trous va vers le bas.**

• Sujete un **canal de soporte (AFM)** a los **paneles murales (AGW y AGY)** usando cuatro (4) **tornillos (ADZ)**. **El extremo con dos agujeros va hacia abajo.**

• No Screw in bottom hole.
• Aucune vis dans le trou inférieur.

• Ningún tornillo en el agujero inferior.

• Bottom End
• Extrémité inférieure
• Extremo inferior

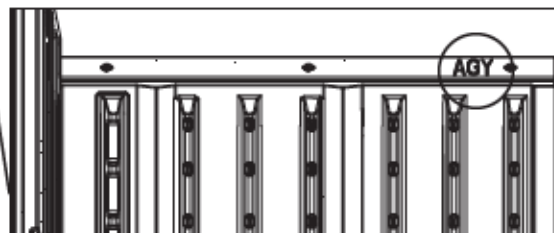
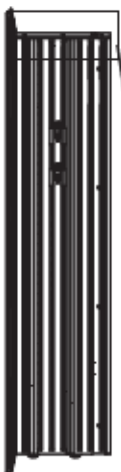
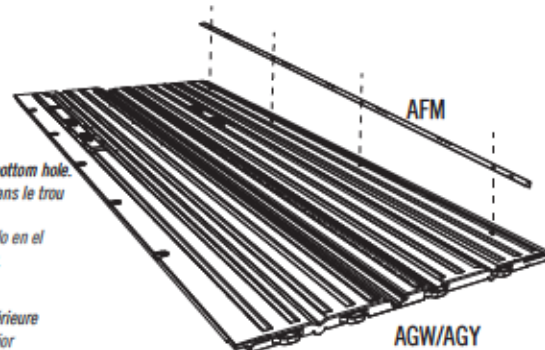

► SECTION 8 (CONTINUED) / SECTION 8 (SUITE) / SECCIÓN 8 (CONTINUACIÓN)

TOOLS AND PARTS REQUIRED / OUTILS ET QUINCAILLERIE REQUIS / INSTRUMENTAL Y HERRAJE REQUERIDOS

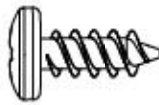

ADZ (x16)

8.3

• Top End
• Extrémité supérieure
• Extremo superior

- Secure a **Wall Support Channel (AFM)** to the **Corner Wall Panels (AGL and AGN)** using four (4) **Screws (ADZ)**. The end with two holes goes at the top.
- Attachez un canal de support (AFM) aux panneaux muraux (AGL et AGN) à l'aide de quatre (4) vis (ADZ). L'extrémité avec deux trous va vers le haut.
- Sujete un canal de soporte (AFM) a los paneles murales (AGL y AGN) usando cuatro (4) tornillos (ADZ). El extremo con dos agujeros va hacia arriba.

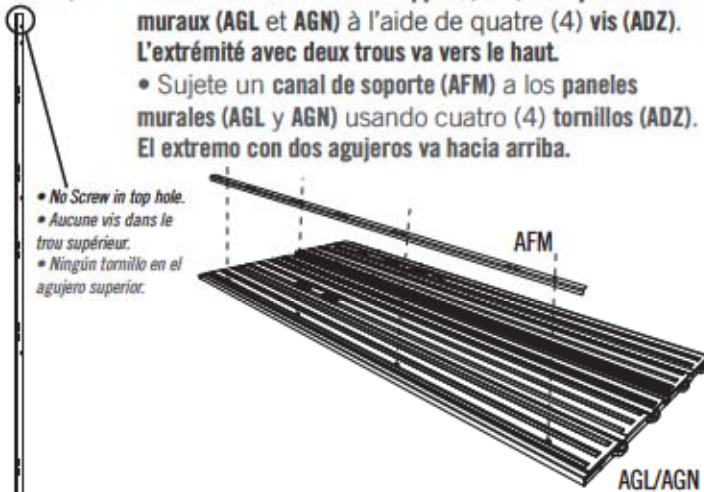

• No Screw in top hole.
• Aucune vis dans le trou supérieur.
• Ningún tornillo en el agujero superior.

8.4

• Top End
• Extrémité supérieure
• Extremo superior

- Secure a **Wall Support Channel (AFM)** to the **Left Narrow Wall Panel (CKK)** using four (4) **Screws (ADZ)**. The end with two holes goes at the top.
- Attachez un canal de support (AFM) au panneau mural étroit gauche (CKK) à l'aide de quatre (4) vis (ADZ). L'extrémité avec deux trous va vers le haut.
- Sujete un canal de soporte (AFM) al panel mural angosto izquierdo (CKK) usando cuatro (4) tornillos (ADZ). El extremo con dos agujeros va hacia arriba.

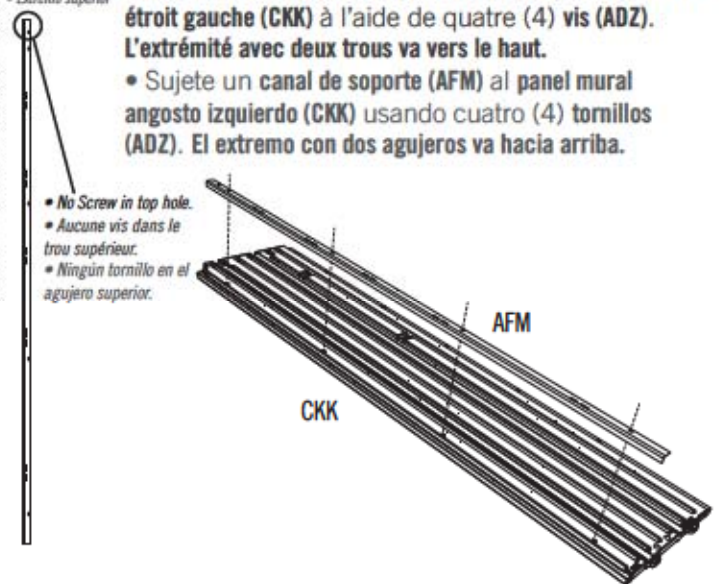

• No Screw in top hole.
• Aucune vis dans le trou supérieur.
• Ningún tornillo en el agujero superior.

8.5

- Secure a **Wall Support Channel (AFM)** to the **Right Narrow Wall Panel (CKN)** using four (4) **Screws (ADZ)**. The end with two holes goes at the bottom.
- Attachez un canal de support (AFM) au panneau mural étroit droit (CKN) à l'aide de quatre (4) vis (ADZ). L'extrémité avec deux trous va vers le bas.
- Sujete un canal de soporte (AFM) al panel mural angosto derecho (CKN) usando cuatro (4) tornillos (ADZ). El extremo con dos agujeros va hacia abajo.

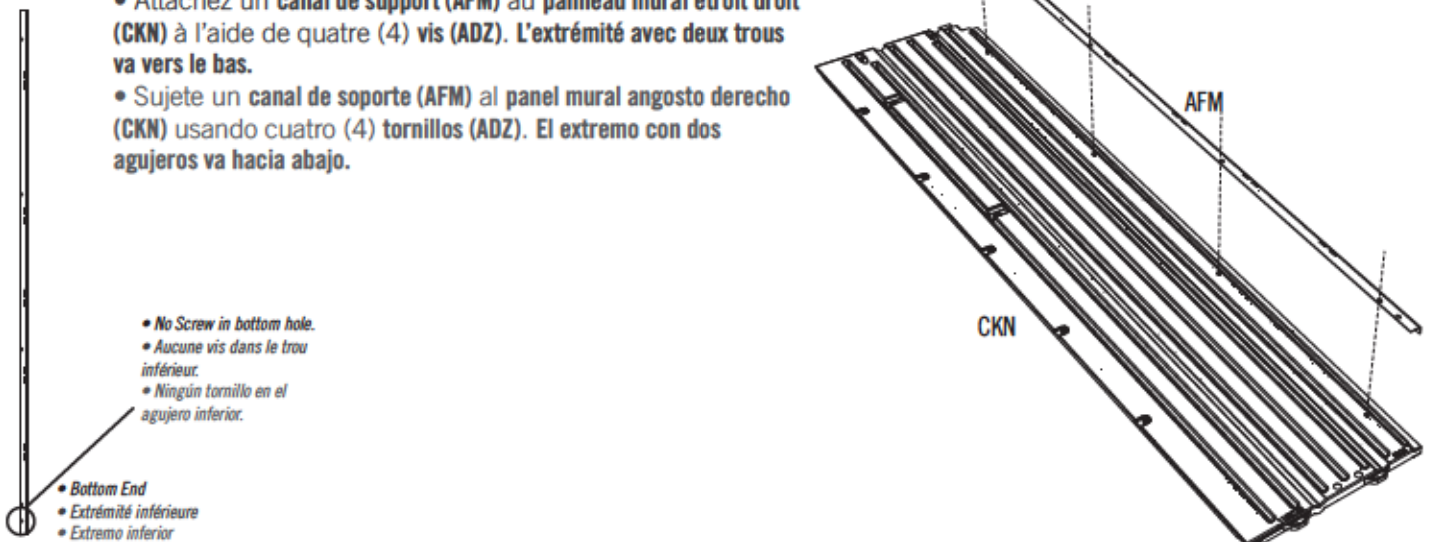

• No Screw in bottom hole.
• Aucune vis dans le trou inférieur.
• Ningún tornillo en el agujero inferior.

• Bottom End
• Extrémité inférieure
• Extremo inferior

► SECTION 8 (CONTINUED) / SECTION 8 (SUITE) / SECCIÓN 8 (CONTINUACIÓN)

TOOLS AND PARTS REQUIRED / OUTILS ET QUINCAILLERIE REQUIS / INSTRUMENTAL Y HERRAJE REQUERIDOS



AW (x1)

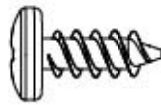

ADZ (x5)

8.6

- Insert the two tabs at the bottom of the **Narrow Wall Panel (CKN)** into the eleventh and twelfth slots from the right along the front edge of the Floor.
- Insérez les deux languettes au bord inférieur du **panneau mural étroit (CKN)** dans les onzième et douzième rainures du coin droit le long du bord avant du plancher.
- Introduzca las dos lengüetas al borde inferior del **panel mural angosto (CKN)** en las undécima y duodécima ranuras de la esquina derecha a lo largo del borde delantero del piso.



8.7

- Slide the Panel to the left.
- Glissez le panneau à gauche.
- Deslice el panel a la izquierda.

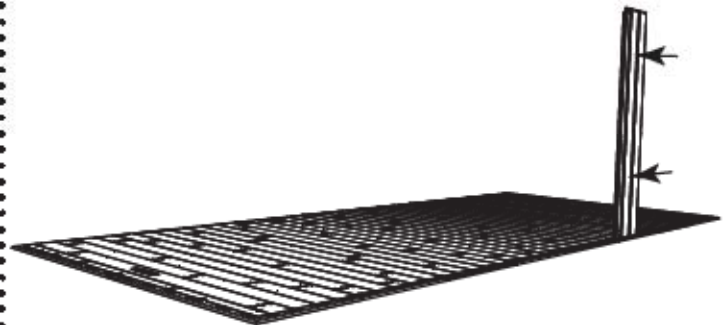

8.8

- Insert the four tabs at the bottom of the **Window Wall Panel (AHH)** into the 7th–10th slots from the right along the front edge of the Floor. **Slide the Panel up against the Narrow Wall Panel.**
- Insérez les quatre languettes au bord inférieur du **panneau mural étroit (CKN)** dans les 7e – 10e rainures du coin droit le long du bord avant du plancher. **Glissez le panneau contre le panneau mural étroit.**
- Introduzca las cuatro lengüetas al borde inferior del **panel mural para la ventana (CKN)** en las 7ª–10ª ranuras de la esquina derecha a lo largo del borde delantero del piso. **Deslice el panel contra el panel mural angosto.**



8.9

- Secure the two Panels together using five (5) **Screws (ADZ)**. **Do not overtighten the Screws.**
- Attachez bien les deux panneaux l'un à l'autre à l'aide de cinq (5) **vis (ADZ)**. **Ne serrez pas excessivement les vis.**
- Sujete los dos paneles el uno al otro usando cinco (5) **tornillos (ADZ)**. **No apriete demasiado los tornillos.**

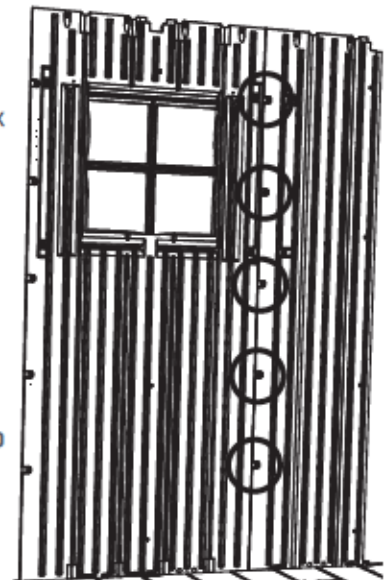

► SECTION 8 (CONTINUED) / SECTION 8 (SUITE) / SECCIÓN 8 (CONTINUACIÓN)

TOOLS AND PARTS REQUIRED / OUTILS ET QUINCAILLERIE REQUIS / INSTRUMENTAL Y HERRAJE REQUERIDOS



AW (x1)

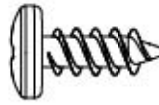

ADZ (x10)

8.10

- Insert the **Wall Panel (AHD)** in the next four available slots, and slide the Panel to the left. **Do not overtighten the Screws.**
- Insérez le **panneau mural (AHD)** dans les quatre rainures suivantes disponibles, et glissez le panneau à gauche. **Ne serrez pas excessivement les vis.**
- Inserte **panel mural (AHD)** en las cuatro ranuras disponibles siguientes, y deslice el panel a la izquierda. **No apriete demasiado los tornillos.**

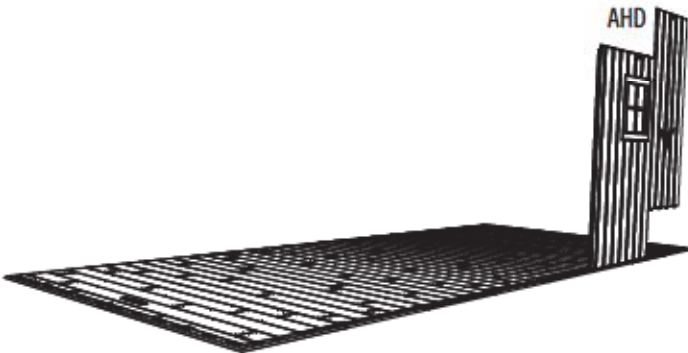

- You may install the **Side Doors** on either end; however, you will need to install the **Corner Panels (AGN & AGY)** on the same end as you do the Doors.

- Vous pouvez installer les **portes latérales** dans le côté droit ou le côté gauche; néanmoins, il faut installer les **panneaux angulaires (AGN et AGY)** dans le même côté que les portes.
- Se pueden instalar las **puertas laterales** en el lado derecho o izquierdo; sin embargo, es preciso instalar los **paneles angulares (AGN y AGY)** en el mismo lado que las puertas.

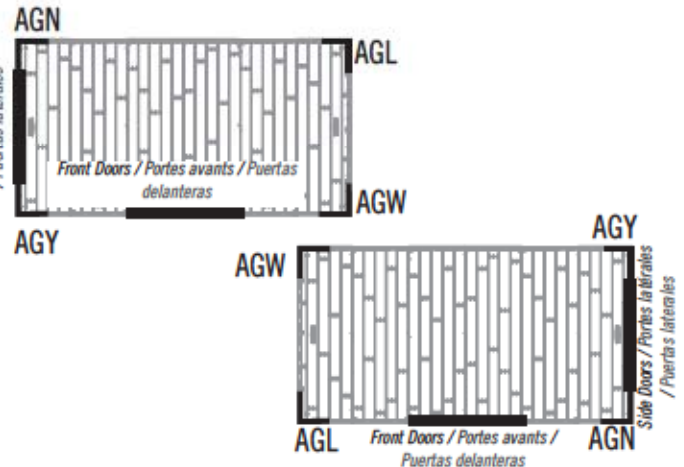

8.11

- Insert the two rear-most tabs at the bottom of the **Front, Right Corner Wall Panel (AGW)** in the first two corner side slots, and slide the Panel toward the front of the Floor as far as it will go.
- Insérez les deux languettes arrières au bord inférieur du **panneau mural angulaire avant droit (AGW)** dans les premières deux rainures latérales, et glissez le panneau autant que possible vers le bord avant du plancher.
- Inserte las dos lengüetas traseras al borde inferior del **panel mural angular delantero derecho (AGW)** en las primeras dos ranuras laterales, y deslice el panel en lo posible hacia el borde delantera del piso.

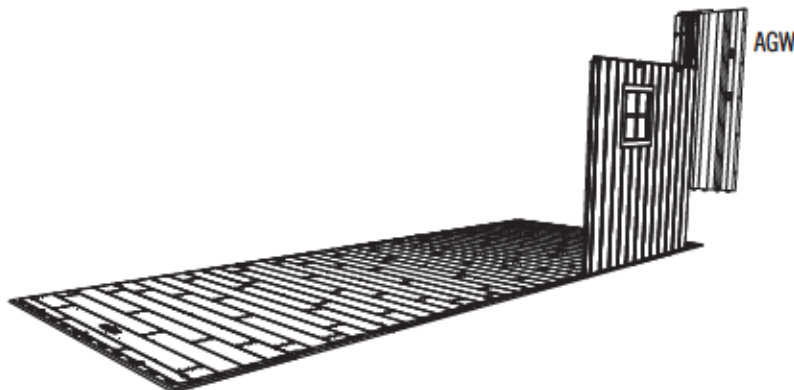

► SECTION 8 (CONTINUED) / SECTION 8 (SUITE) / SECCIÓN 8 (CONTINUACIÓN)

TOOLS AND PARTS REQUIRED / OUTILS ET QUINCAILLERIE REQUIS / INSTRUMENTAL Y HERRAJE REQUERIDOS



AIW (x1)

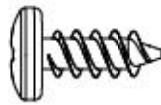

ADZ (x55)

8.12

• Bend Corner Panel and pull down on the Panel to snap the remaining tabs in place. To help with insertion, place the **Wood Block (AIW)** under the Floor Panel directly under the tab being inserted. You should hear a "click" when the tab pops into place. **Repeat this step for the second tab.** Secure with five (5) **Screws (ADZ)**.

• Pliez le panneau angulaire et insérez les autres languettes. Pour aider avec le montage, mettez le **bloque en bois (AIW)** sous le panneau de plancher directement sous la languette que vous voulez insérer. **Répétez ce processus pour la deuxième languette.** Attachez-le au panneau mural à l'aide de cinq (5) **vis (ADZ)**.

• Doble el panel angular e introduzca las lengüetas restantes. Para ayudar con el armado, deslice el **Bloque de madera (AIW)** debajo el panel de piso directamente debajo la lengüeta que quiere insertar. Se escucha un «clic» cuando la lengüeta se sienta en su lugar. **Repita este proceso para la segunda lengüeta.** Sujételo al panel mural usando cinco (5) **tornillos (ADZ)**.

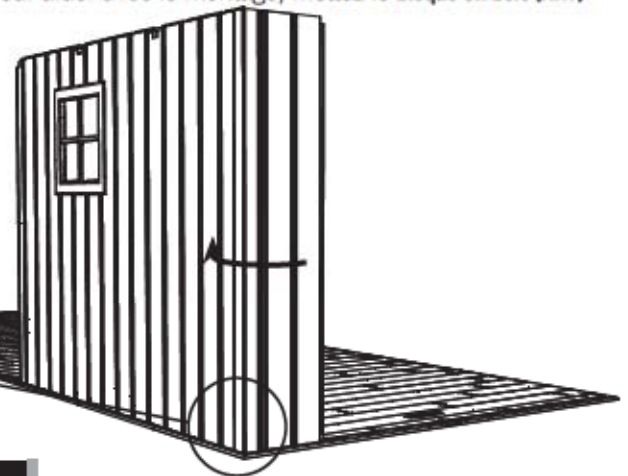
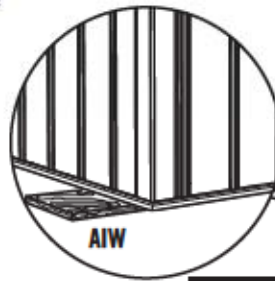

8.13

• Insert the four tabs at the bottom of the **Wall Panels (AHD)** into the next four slots along the edge of the Floor, and slide the Panel forward. Attach the Panels together with five (5) **Screws (ADZ)** each.

• Insérez les quatre languettes au bord inférieur des **panneaux muraux (AHD)** dans les quatre rainures suivantes le long du bord du plancher, et glissez les panneaux vers le bord avant. Attachez les panneaux l'un à l'autre à l'aide de cinq (5) **vis (ADZ)**.

• Inserte las cuatro lengüetas al borde inferior de los **paneles murales (AHD)** en las cuatro ranuras siguientes a lo largo del borde del piso, y deslice los paneles hacia el borde delantero. Sujete los paneles los unos a los otros usando cinco (5) **tornillos (ADZ)**.



8.14

• Insert this **Corner Wall Panel (AGL)** in the same way as the first one. Secure with four (4) **Screws (ADZ)**.

• Insérez le **panneau angulaire (AGL)** dans la même manière que le premier panneau angulaire. Attachez-le à l'aide de quatre (4) **vis (ADZ)**.

• Inserte este **panel angular (AGL)** en la misma manera que el primer panel angular. Sujételo con cuatro **tornillos (ADZ)**.

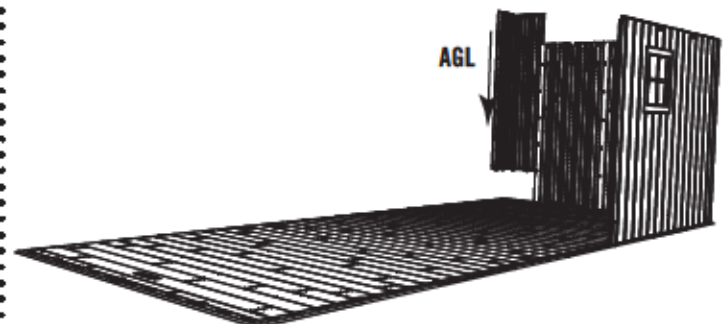

► SECTION 8 (CONTINUED) / SECTION 8 (SUITE) / SECCIÓN 8 (CONTINUACIÓN)

TOOLS AND PARTS REQUIRED / OUTILS ET QUINCAILLERIE REQUIS / INSTRUMENTAL Y HERRAJE REQUERIDOS



AIW (x1)

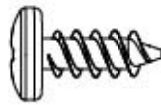

ADZ (x20)

8.15

- Insert seven **Wall Panels (AHD)** along the back of the Floor in the same way as the previous ones.
- Insérez sept **panneaux muraux (AHD)** le long du bord arrière du Plancher dans la même manière que les panneaux précédents.
- Inserte siete **paneles murales (AHD)** a lo largo del borde trasero en la misma manera que los paneles anteriores.

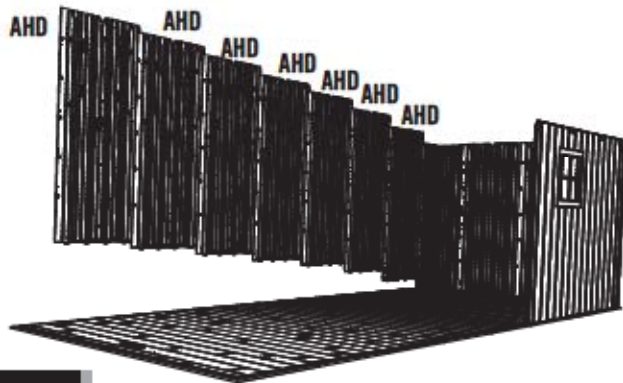

8.16

- Insert this **Corner Wall Panel (AGN)** in the same way as the first one. Secure with five (5) **Screws (ADZ)**.
- Insérez le **panneau angulaire (AGN)** dans la même manière que le premier panneau angulaire. Attachez-le à l'aide de cinq (5) **vis (ADZ)**.
- Inserte este **panel angular (AGN)** en la misma manera que el primer panel angular. Sujételo con cinco (5) **tornillos (ADZ)**.

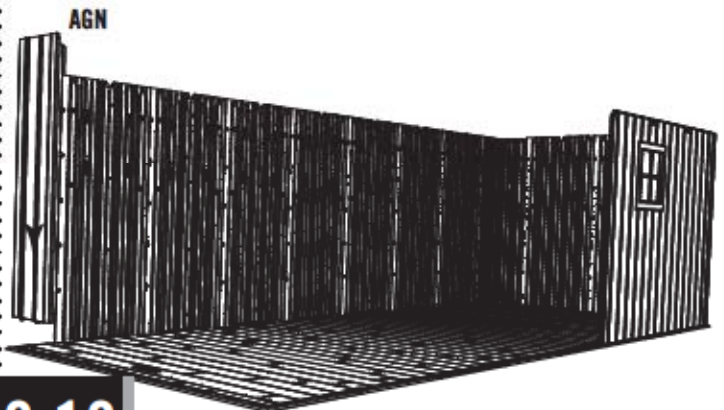

8.17

- Insert this **Corner Wall Panel (AGY)** in the same way as the first one. Secure with five (5) **Screws (ADZ)**.
- Insérez le **panneau angulaire (AGY)** dans la même manière que le premier panneau angulaire. Attachez-le à l'aide de cinq (5) **vis (ADZ)**.
- Inserte este **panel angular (AGY)** en la misma manera que el primer panel angular. Sujételo con cinco (5) **tornillos (ADZ)**.

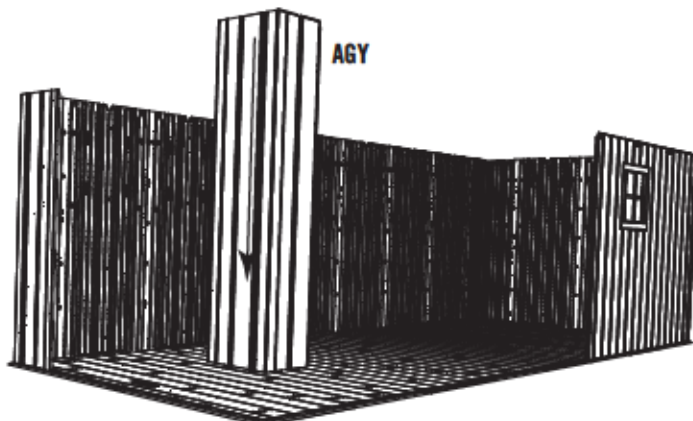

8.18

- Insert the next three **Panels (AHD, AHH, and CKK)** in the order shown. Secure with five (5) **Screws (ADZ)** each.
- Insérez le **panneau (AHD, AHH, et CKK)** dans l'ordre illustré. Attachez-les à de cinq (5) **vis (ADZ)** chaque un.
- Inserte los tres **paneles (AHD, AHH, y CKK)** en el orden ilustrado. Sujételos con cinco (5) **tornillos (ADZ)** cada uno.

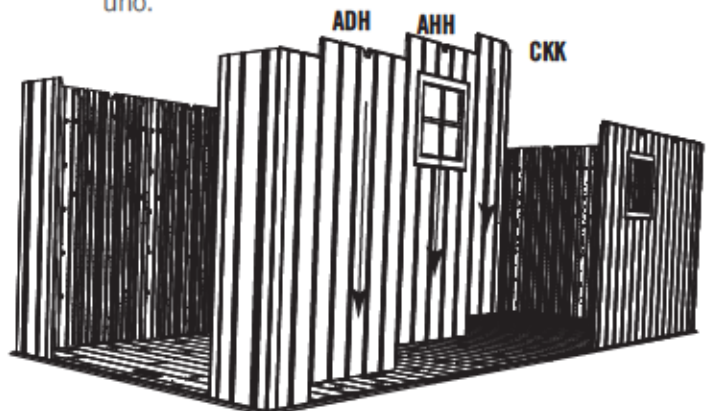



PARTS IDENTIFIER / IDENTIFICATEUR DE PIÈCES / IDENTIFICADOR DE PIEZAS

CONTENTS OF BOX 1 / CONTENU DE LA BOÎTE 1 / CONTENIDO DE LA CAJA 1

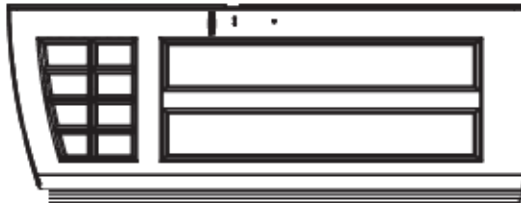

BDJ (x1)



BDK (x1)

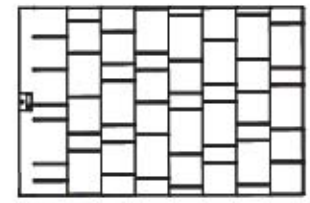

AGQ (x6)



AGF (x1)



BDC (x1)



AGH (x1)

AGI (x1)



CUW (x2)

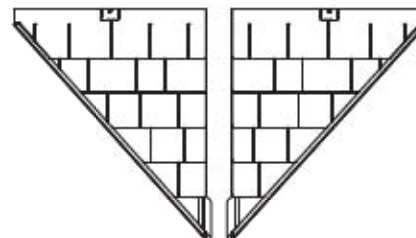

BDR (x1)

BDS (x1)

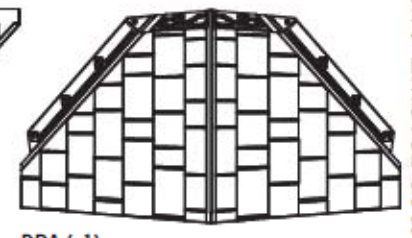

DRA (x1)

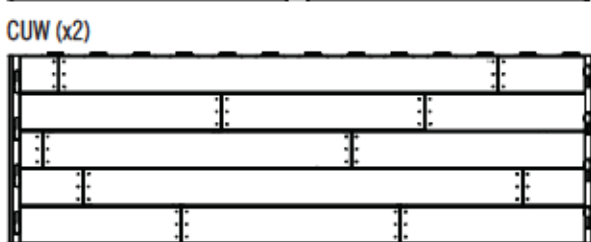

CUD (x2)

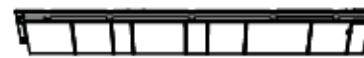

45 1/2 in/po (1,16 m)
CVC (x2)



45 1/2 in/po (1,16 m)
CVE (x2)

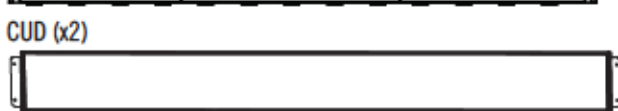

AFV (x1)



CVG (x4)

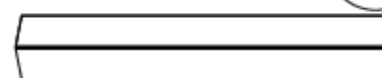

CVA (x2)

CONTENTS METAL KIT 2 / CONTENU DU KIT DE PIÈCES EN MÉTAL 2 / CONTENIDO DEL KIT DE PIEZAS DE METAL 2

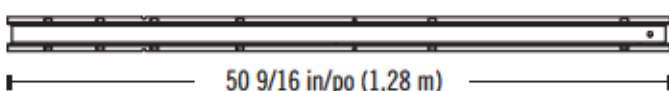

DSR (x3)

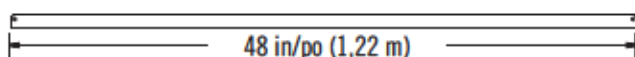

AFG (x3)

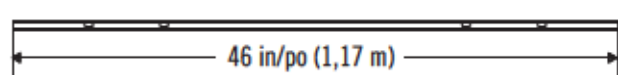

BDD (x1)



DSQ (x2)

50 9/16 in/po (1,28 m)

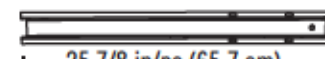

DSM (x1)

25 7/8 in/po (65,7 cm)

Remove This Section / Enlever cette section / Retire esta sección



PARTS IDENTIFIER / IDENTIFICATEUR DE PIÈCES / IDENTIFICADOR DE PIEZAS

CONTENTS METAL KIT 1 / CONTENU DU KIT DE PIÈCES EN MÉTAL 1 / CONTENIDO DEL KIT DE PIEZAS DE METAL 1

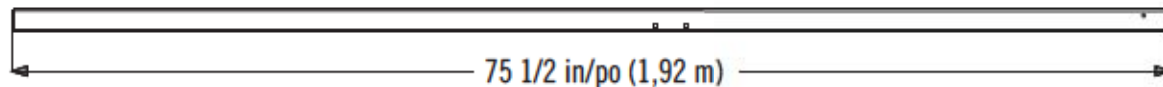

BLH (x2)

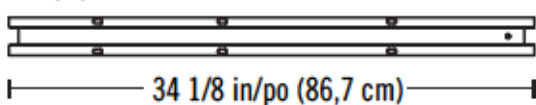

DSO (x1)

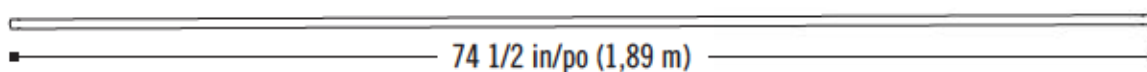

CRE (x2)

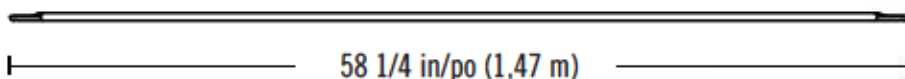

DSP (x1)

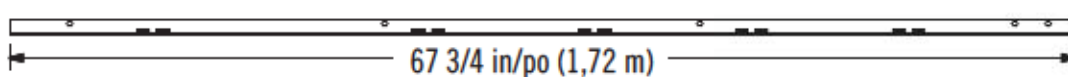

AFM (x13)

Remove This Section / Retirez esta sección / Retirez cette section / Enlevez cette section

CONTENTS OF BOX 2 / CONTENU DE LA BOÎTE 2 / CONTENIDO DE LA CAJA 2

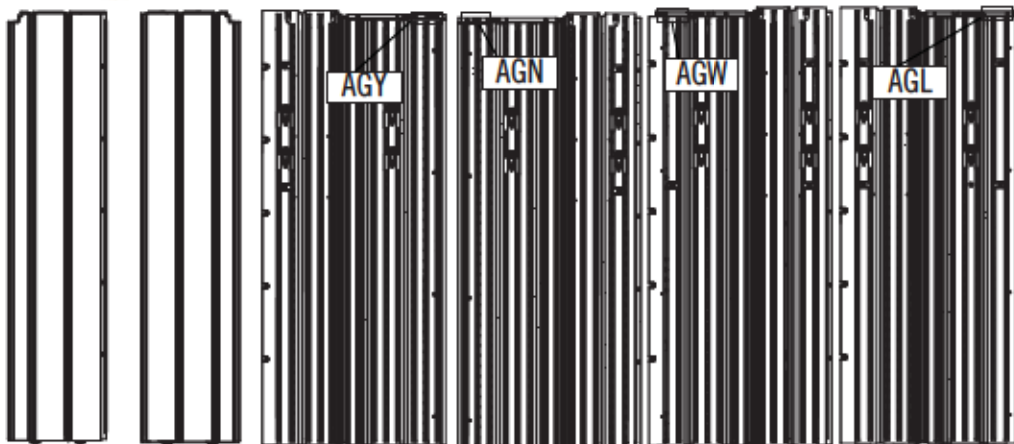

CKN (x1)

CKK (x1)

AGY (x1)

AGN (x1)

AGW (x1)

AGL (x1)



AHD (x5)

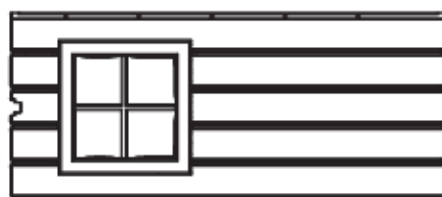

AHH (x2)



PARTS IDENTIFIER / IDENTIFICATEUR DE PIÈCES / IDENTIFICADOR DE PIEZAS

CONTENTS SMALL PARTS BOX 1 / CONTENU DE LA BOÎTE DE PETITES PIÈCES 1 / CONTENIDO DE LA CAJA DE PIEZAS PEQUEÑAS 1



CVF (x5)



DRB (x1)



31 in/po (79 cm)
CVD (x10)



AFL (x16)

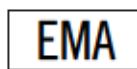

EGQ (x26)

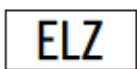

19 3/4 in/po (50,2 cm)
BRD (x7)

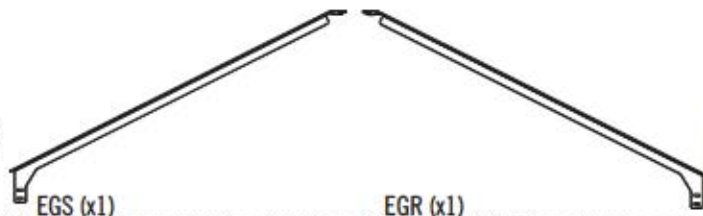

EGS (x1)

EGR (x1)

CONTENTS OF BOX 3 / CONTENU DE LA BOÎTE 3 / CONTENIDO DE LA CAJA 3

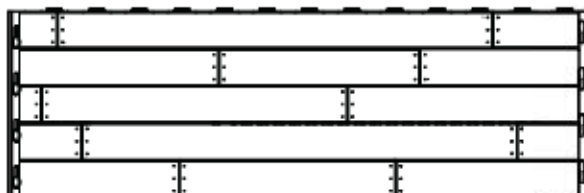

CUD (x4)

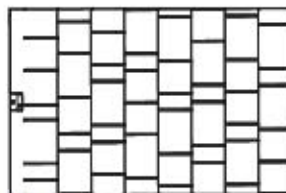

AGQ (x6)

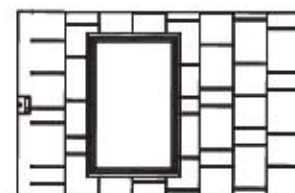

AHB (x2)

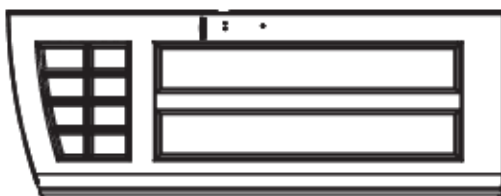

BDJ (x1)



BDK (x1)



DQB (x4)

CONTENTS METAL KIT 3 / CONTENU DU KIT DE PIÈCES EN MÉTAL 3 / CONTENIDO DEL KIT DE PIEZAS DE METAL 3

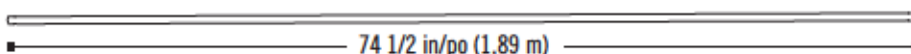

CRD (x2)

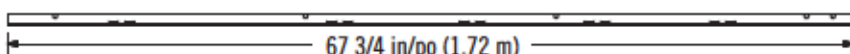

AFM (x4)



DSR (x3)

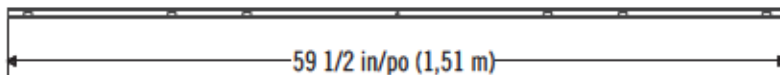

AFE (x1)

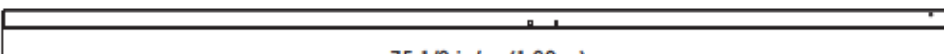

BLH (x2)

CONTENTS METAL KIT 4 / CONTENU DU KIT DE PIÈCES EN MÉTAL 4 / CONTENIDO DEL KIT DE PIEZAS DE METAL 4

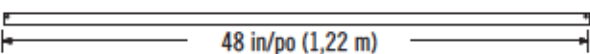

AFG (x4)

Remove This Section / Enlevez cette section / Retire esta sección



PARTS IDENTIFIER / IDENTIFICATEUR DE PIÈCES / IDENTIFICADOR DE PIEZAS

CONTENTS METAL KIT 4 / CONTENU DU KIT DE PIÈCES EN MÉTAL 4 / CONTENIDO DEL KIT DE PIEZAS DE METAL 4



50 9/16 in/po (1,28 m)

DSR (x5)



CONTENTS OF BOX 4 / CONTENU DE LA BOÎTE 4 / CONTENIDO DE LA CAJA 4



AHD (x6)

Remove This Section / Enlevez cette section / Retire esta sección

CONTENTS SMALL PARTS BOX 2 / CONTENU DE LA BOÎTE DE PIÈCES EN MÉTAL 2 / CONTENIDO DE LA CAJA DE PIEZAS PEQUEÑAS 2

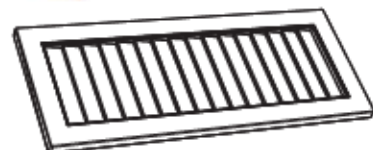

AYI (x4)



8 7/16 in/po (21,4 cm) DSN (x1)



AIP (x7)

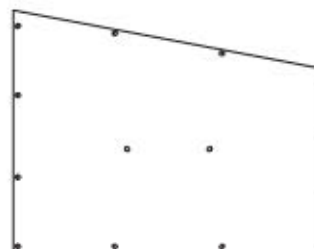

DHN (x4)



AIW (x1)



AIX (x4)



AHE (x2)



CVB (x2)

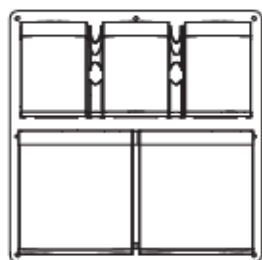

EDI (x2)

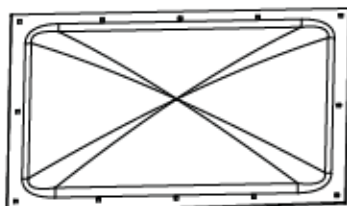

AGB (x2)

Hardware Bags / Sacs de quincaillerie / Bolsas de herraje



9

SHELVING INSTALLATION / INSTALLATION DU RAYONNAGE / INSTALACIÓN DE LA ESTANERÍA



HARDWARE REQUIRED / QUINCAILLERIE REQUISE / HERRAJE REQUERIDO

Hardware Bag / Sac de quincaillerie / Bolsa de herraje

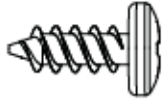

ADZ (x14)



AIY (x2)



PARTS REQUIRED / PIÈCES REQUISES / PIEZAS REQUERIDAS

Plastic Parts / Pièces en plastique / Piezas de plástico



AFV (x1)



TOOLS REQUIRED / OUTILS REQUIS / INSTRUMENTAL REQUERIDO



► SECTION 9 (CONTINUED) / SECTION 9 (SUITE) / SECCIÓN 9 (CONTINUACIÓN)

TOOLS AND PARTS REQUIRED / OUTILS ET QUINCAILLERIE REQUIS / INSTRUMENTAL Y HERRAJE REQUERIDOS



9.1

- Choose how high you would like the Long Shelf to be by selecting the corresponding notches (there are five) in the Wall Support Channels, and insert the two **Shelf Brackets (AIY)** into the slots in the Wall Support Channels. **The Brackets must be at the same height.**
- Choisir la hauteur d'installation de l'étagère longue par sélectionner les deux encoches correspondantes (il y a cinq) dans les supports muraux, et insérer les **équerres (AIY)** dans les fentes dans les canaux de support pour les murs. **Les équerres doivent être à la même hauteur.**
- Escoger la altura de instalación del estante largo por seleccionar las ranas correspondientes (hay cinco) en los soportes murales, e insertar las **escuadras (AIY)** en las ranas en los canales de soporte para los muros. **Las escuadras deben estar a la misma altura.**

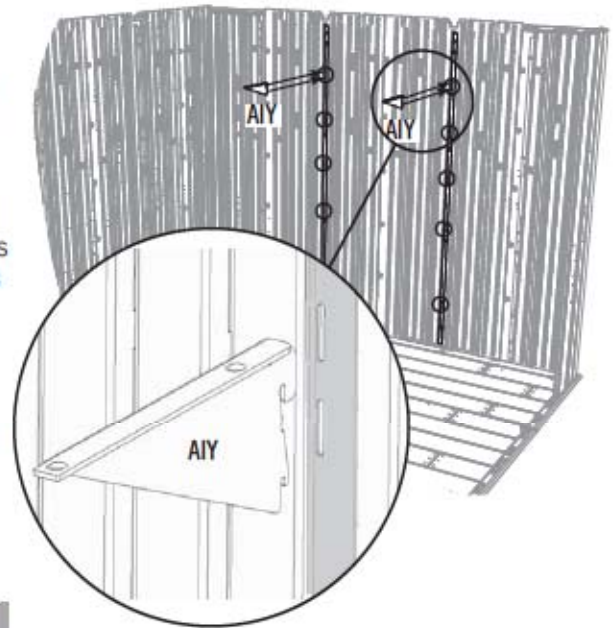

- There are five notches along the back edge of the **Long Shelf (AFV)**. These notches should be against the Rear Wall.
- Il y a cinq encoches le long du bord arrière de l'étagère longue (AFV). Ces encoches doivent rester contre le mur arrière.
- Hay cinco muescas a lo largo del borde trasero del **estante largo (AFV)**. Estas muescas deben quedarse contra el muro trasero.



9.2

- Fold the tabs on the end of the Long Shelf upward.
- Plier les languettes aux extrémités de l'étagère longue vers le haut.
- Plegar las lengüetas a los extremos del estante largo hacia arriba.



► SECTION 9 (CONTINUED) / SECTION 9 (SUITE) / SECCIÓN 9 (CONTINUACIÓN)

TOOLS AND PARTS REQUIRED / OUTILS ET QUINCAILLERIE REQUIS / INSTRUMENTAL Y HERRAJE REQUERIDOS

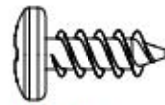

ADZ (x4)

9.3

- Set the Shelf down onto the Brackets.
- Mettre l'étagère sur les équerres.
- Colocar el estante en las escuadras.

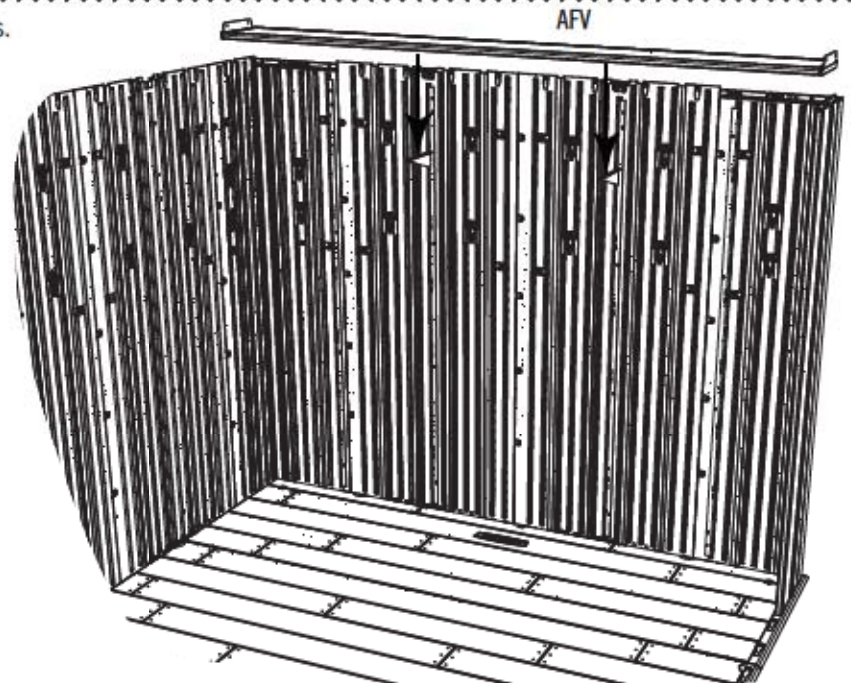

9.4

- Attach the Shelf to the Corner Panels using two (2) Screws (ADZ) at each end.
- Attacher l'étagère aux panneaux angulaires à l'aide de deux (2) vis (ADZ) à chaque extrémité.
- Sujeter el estante a los paneles angulares usando dos (2) tornillos (ADZ) a cada extremo.

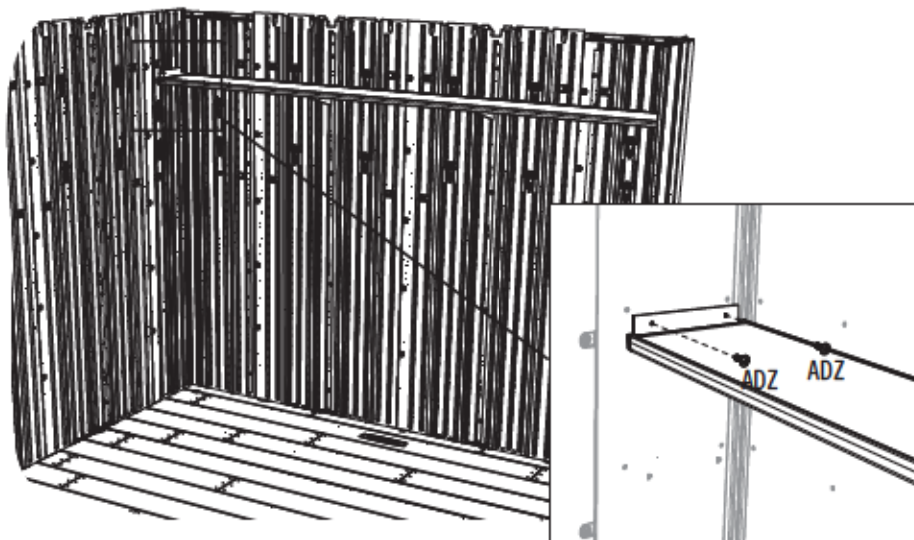

► SECTION 9 (CONTINUED) / SECTION 9 (SUITE) / SECCIÓN 9 (CONTINUACIÓN)

TOOLS AND PARTS REQUIRED / OUTILS ET QUINCAILLERIE REQUIS / INSTRUMENTAL Y HERRAJE REQUERIDOS

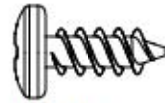

ADZ (x2)

9.5

- Attach the **Shelf (AFV)** to the Shelf Brackets using two (2) **Screws (ADZ)**—one (1) at the front of each Bracket.
- Attacher l'**étagère (AFV)** aux équerres à l'aide de deux (2) **vis (ADZ)** — une (1) à la partie avant de chaque équerre.
- Sujetar el **estante (AFV)** a las escuadras usando dos (2) **tornillos (ADZ)**, uno (1) a la parte delantera de cada escuadra.

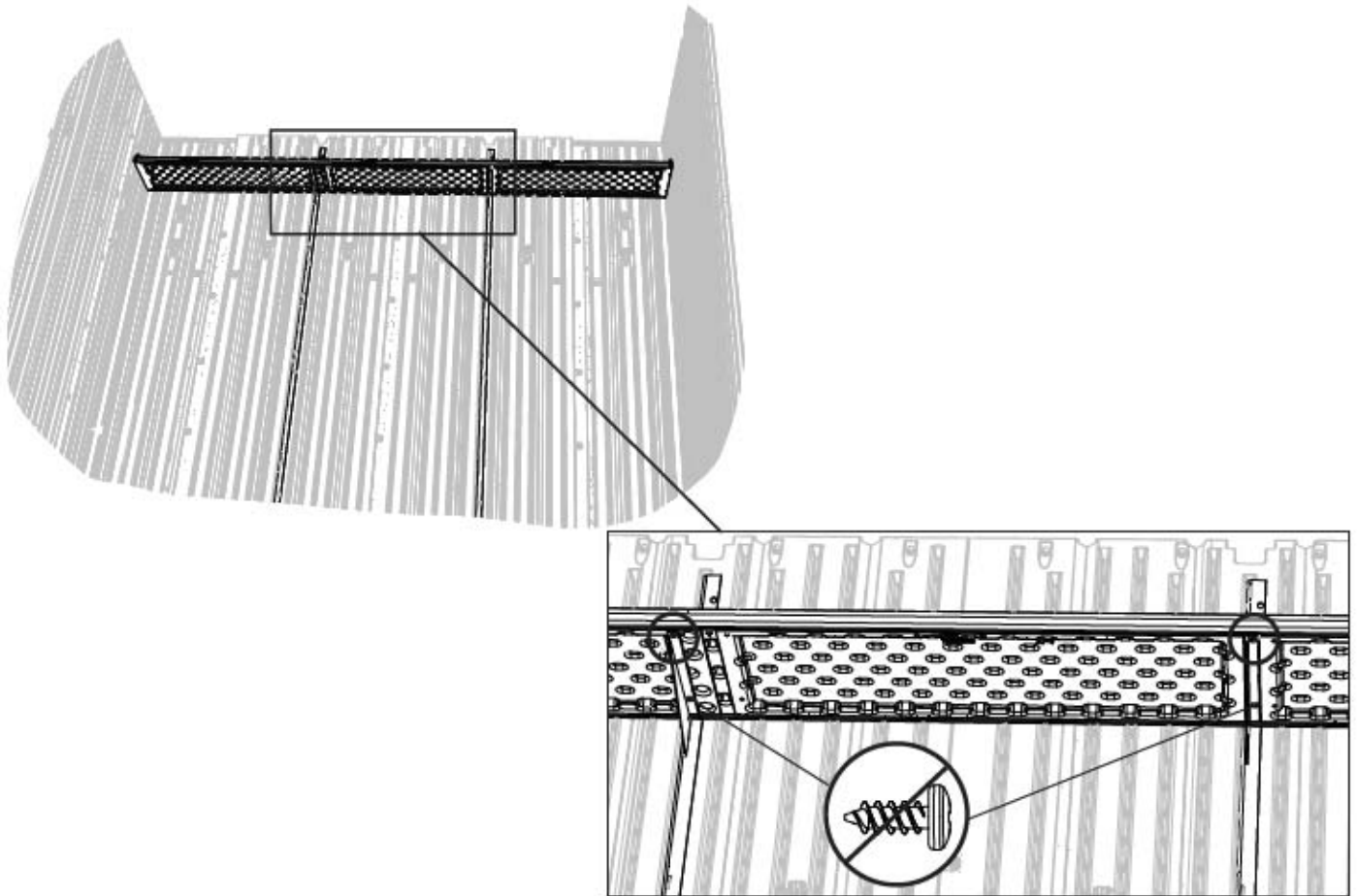



HARDWARE REQUIRED / QUINCAILLERIE REQUISE / HERRAJE REQUERIDO

Hardware Bags / Sacs de quincaillerie / Bolsas de herraje



ADX (x4)



DTV (x2)



CUZ (x4)



AHP (x4)



CWU (x24)

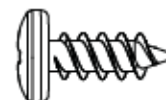

ADZ (x300)



AEE (x2)



CKX (x2)



AXX (x2)

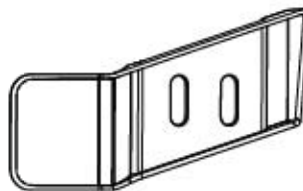

AIM (x1)

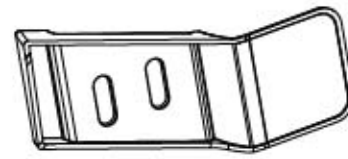

AIC (x1)



BZA (x2)



AEE (x4)



ADK (x2)



ECS (x1)



ECR (x1)



PARTS REQUIRED / PIÈCES REQUISES / PIEZAS REQUERIDAS

Metal Parts / Pièces en métal / Piezas de metal



AFL (x14)

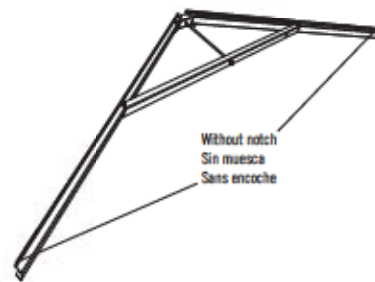

Without notch
Sin muesca
Sans encoche

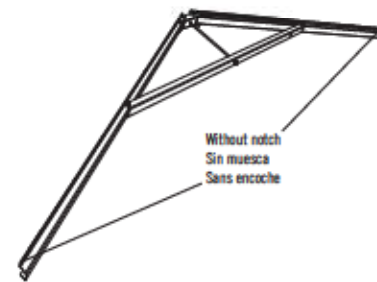

Without notch
Sin muesca
Sans encoche

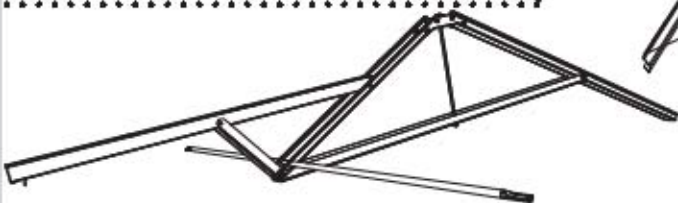

• If you live in an area where snow can become long lasting and extra heavy, Lifetime® offers at cost an additional Snow Load Kit accessory to install in your shed to protect it from the additional weight on the roof. For additional information, please contact our Customer Service Department at 1-800-225-3865.

• Si vous vivez dans une région où la neige peut devenir durable et particulièrement lourde, Lifetime® offre à prix coûtant un kit supplémentaire pour la charge de neige que vous pouvez installer pour protéger l'abri du poids additionnel de la neige. Veuillez contacter notre Département de services à la clientèle pour obtenir plus d'information au 800-225-3865.

• Si vive en un área donde la nieve puede convertirse de larga duración y extra pesada, Lifetime® ofrece a precio de coste un kit suplementario para la carga de nieve que se puede instalar en su caseta para protegerla del peso adicional de la nieve en el tejado. Por favor, póngase en contacto con nuestro Departamento de servicios a clientes para obtener más información al 800-225-3865.

Plastic Parts / Piezas de plástico / Pièces en plastique



45 1/2 in/po (1,16 m)
CVE (x2)



45 1/2 in/po (1,16 m)
CVC (x2)



31 in/po (78,7 cm)
CVD (x10)



CVF (x5)



PARTS REQUIRED / PIÈCES REQUISES / PIEZAS REQUERIDAS

Plastic Parts / Pièces en plastique / Piezas de plástico

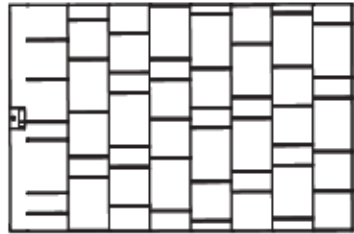

AGQ (x12)

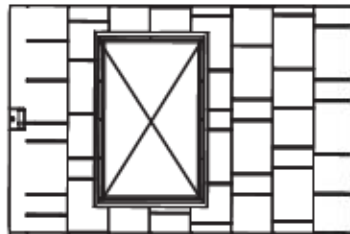

AHB (x2)

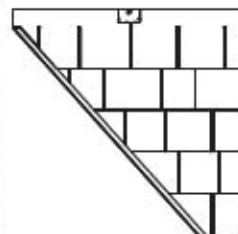

BDR (x1)

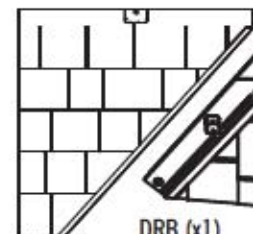

BDS (x1)

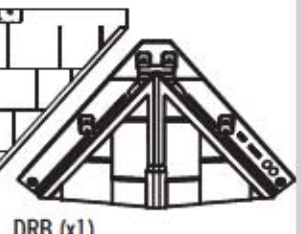

DRB (x1)



(x1)



DRA (x1)

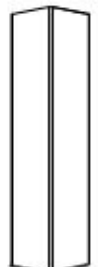

DQB (x4)

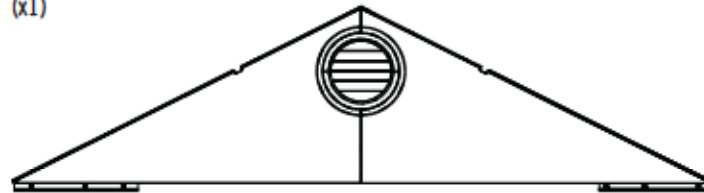

(x1)



CVA (x2)



CVB (x2)



(x1)



CVG (x4)

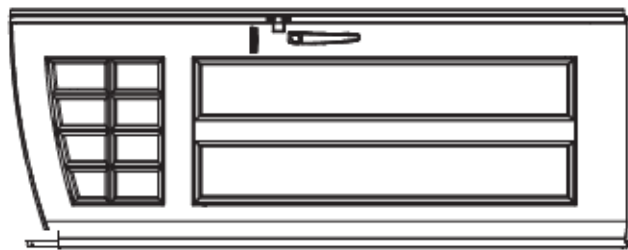

(x2)

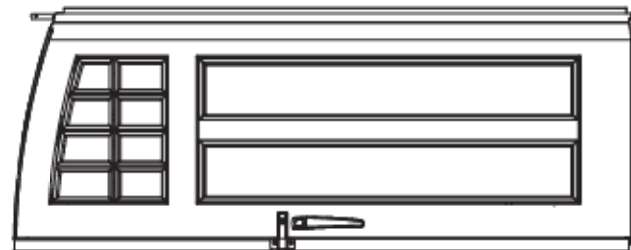

(x2)



TOOLS REQUIRED / OUTILS REQUIS / INSTRUMENTAL REQUERIDO



3/8 in/po
(10 mm)

► SECTION 10 (CONTINUED) / SECTION 10 (SUITE) / SECCIÓN 10 (CONTINUACIÓN)

TOOLS AND PARTS REQUIRED / OUTILS ET QUINCAILLERIE REQUIS / INSTRUMENTAL Y HERRAJE REQUERIDOS



CWU (x24)

10.1

- Attach a **Corner Trim (CVG)** to a corner using six (6) **Screws (CWU)**—two at the top, two in the middle, and two at the bottom. **Repeat for the other corners.**
- Attachez une **moldure (CVG)** à un coin à l'aide des six (6) **vis (CWU)** — deux à la partie supérieure, deux dans le centre, et deux à la partie inférieure. **Répétez pour les autres coins.**
- Sujete una **moldura (CVG)** a una esquina usando seis (6) **tornillos (CWU)**: dos a la parte superior, dos en el centro, y dos a la parte inferior. **Repita para las otras esquinas.**

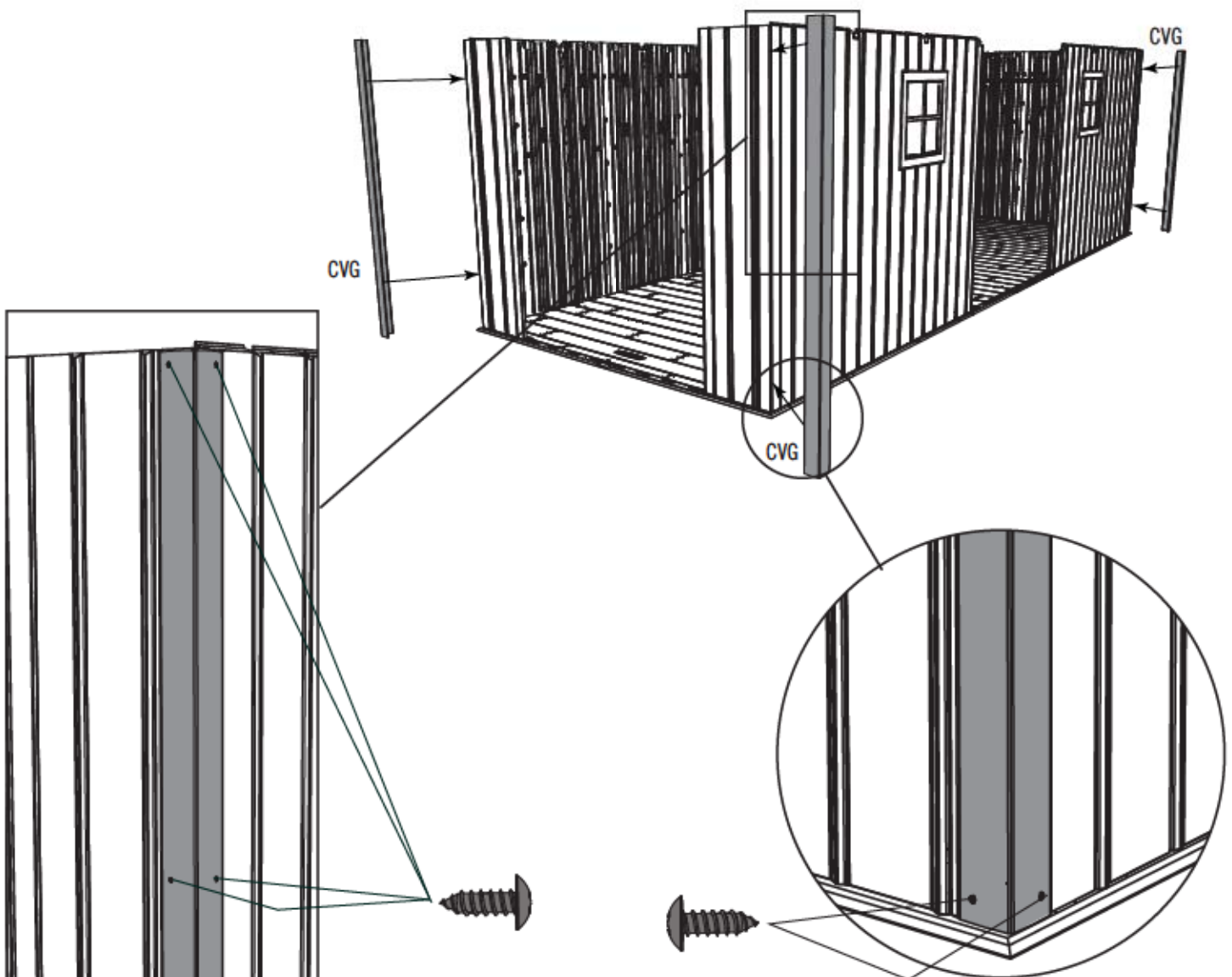

► SECTION 10 (CONTINUED) / SECTION 10 (SUITE) / SECCIÓN 10 (CONTINUACIÓN)

TOOLS AND PARTS REQUIRED / OUTILS ET QUINCAILLERIE REQUIS / INSTRUMENTAL Y HERRAJE REQUERIDOS



AHP (x2)

10.2



• Pull the Hinge Tube down out of the Left Door about six inches. Align the hole at the bottom of the Hinge Tube with the slit in the Bushing, and insert the Tube. Insert a **Cotter Pin (AHP)** and bend the ends.

• Poser le tube d'articulation à peu près quinze centimètres du bord inférieur de la porte gauche. Aligner le trou dans la partie inférieure du tube avec la fente dans la bague, et insérer le tube. Insérer une **goupille fendue (AHP)** et plier les extrémités.

• Extender el tubo de articulación unos quince centímetros del borde inferior de la puerta izquierda. Alinear el agujero en la parte inferior del tubo con la rendija en el casquillo, e insertar el tubo. Insertar una **chaveta (AHP)** y doblar los extremos.

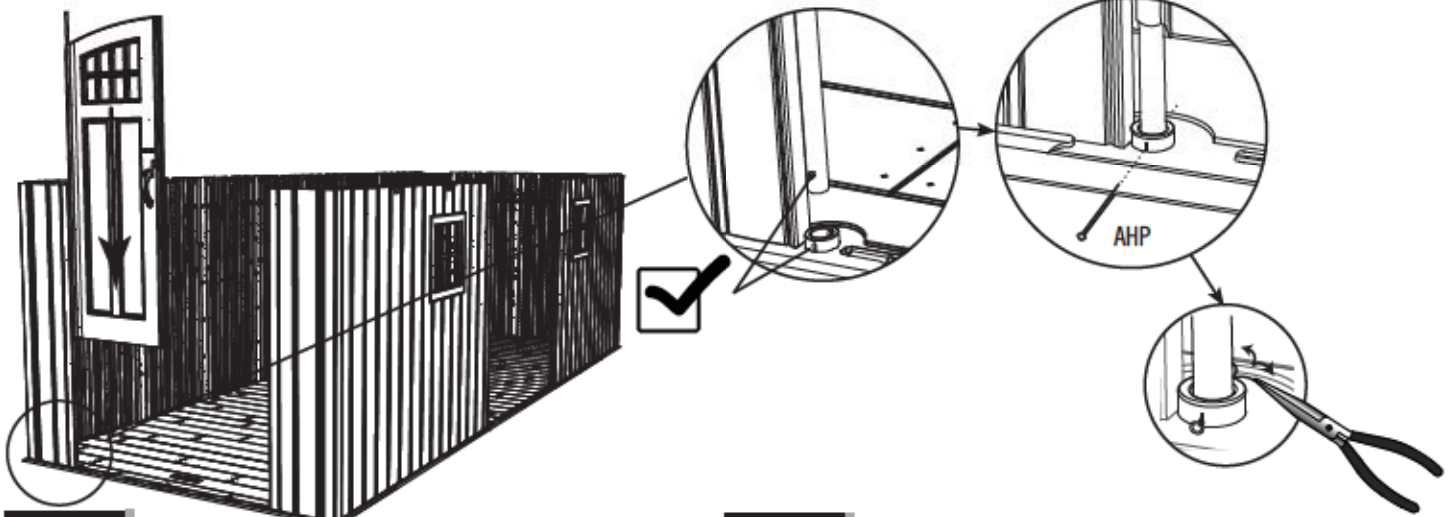

10.3

- Repeat the previous step for the Right Door.
- Répéter l'étape précédente pour la porte droite.
- Repetir el paso anterior para la puerta derecha.



10.4

- Slide the holes in the Entry Gable down over the two Hinge Tubes.
- Faire glisser les trous dans le toit à pignon d'entrée sur les deux tubes.
- Deslizar los agujeros en la fachada de entrada sobre los dos tubos.



► SECTION 10 (CONTINUED) / SECTION 10 (SUITE) / SECCIÓN 10 (CONTINUACIÓN)

TOOLS AND PARTS REQUIRED / OUTILS ET QUINCAILLERIE REQUIS / INSTRUMENTAL Y HERRAJE REQUERIDOS

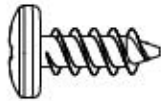

ADZ (x6)

10.5

- Secure the Entry Gable to the shed using six (6) **Screws (ADZ)**.
- Fixer le pignon d'entrée à l'abri à l'aide de six (6) **vis (ADZ)**.
- Fijar la fachada de entrada a la caseta usando seis (6) **tornillos (ADZ)**.

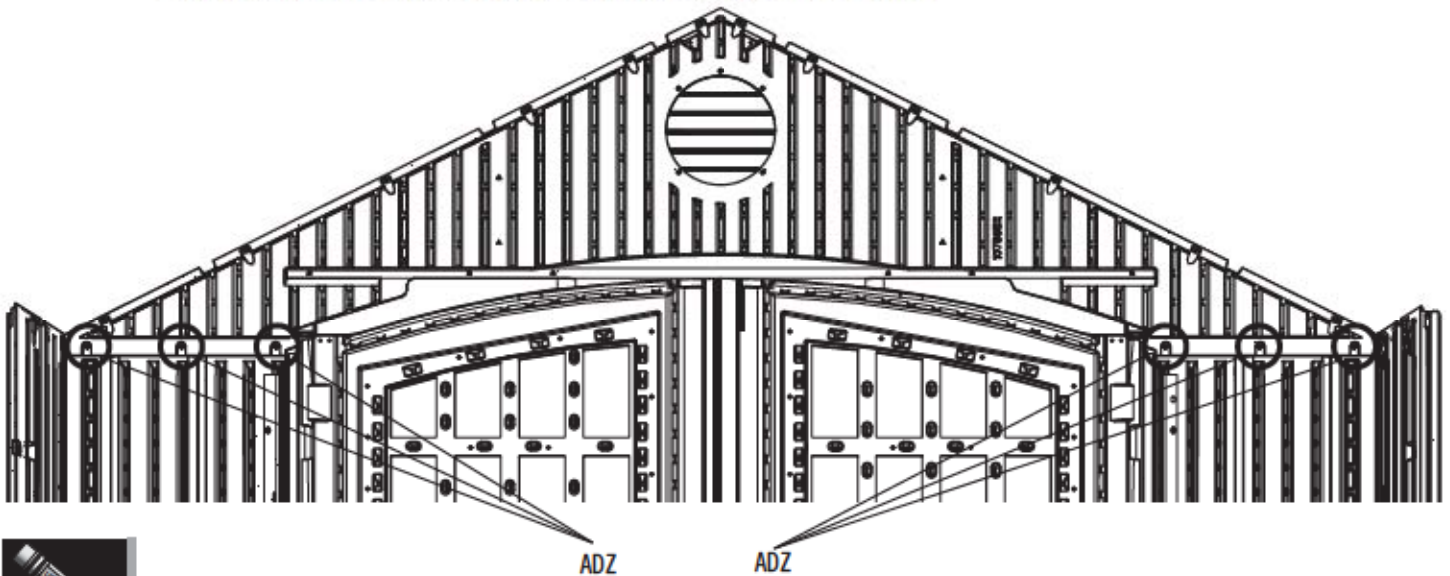

- The Roof Panels for Domed Skylight (AHB) and the regular Roof Panels (AGQ) are interchangeable. They may be installed in any available regular Roof Panel position—be it in the front or back.
- Les panneaux de toit pour la lucarne en forme de dôme (AHB) et les panneaux de toit (AGQ) normals sont interchangeables. On peut les installer dans quiconque emplacement normal — soit dans la partie avant ou dans la partie arrière.
- Los paneles de tejado para el tragaluz en forma de cúpula (AHB) y los paneles de tejado (AGQ) son intercambiables. Se pueden instalarlos en cualquier ubicación normal, sea en la parte delantera o trasera.

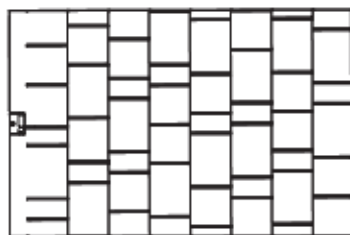

AGQ

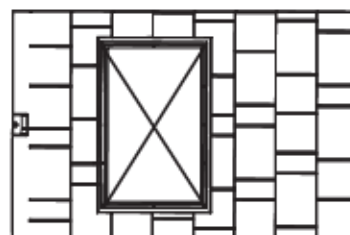

AHB

► SECTION 10 (CONTINUED) / SECTION 10 (SUITE) / SECCIÓN 10 (CONTINUACIÓN)

TOOLS AND PARTS REQUIRED / OUTILS ET QUINCAILLERIE REQUIS / INSTRUMENTAL Y HERRAJE REQUERIDOS



10.6

- Set a Truss Assembly into the notches on the first two opposite Wall Panels. Set a **Roof Panel (AGQ)** onto the Gable, Wall Panel, and Truss Assembly.
- Mettre une ferme dans les encoches des premiers deux panneaux muraux opposés. Mettre un **panneaux de toit (AGQ)** sur le pignon, panneau mural, et la ferme.
- Colocar una cercha dentro de las muescas de los primeros dos paneles de pared opuestos. Colocar un **panel de tejado (AGQ)** sobre la fachada de entrada, panel mural, y la cercha.

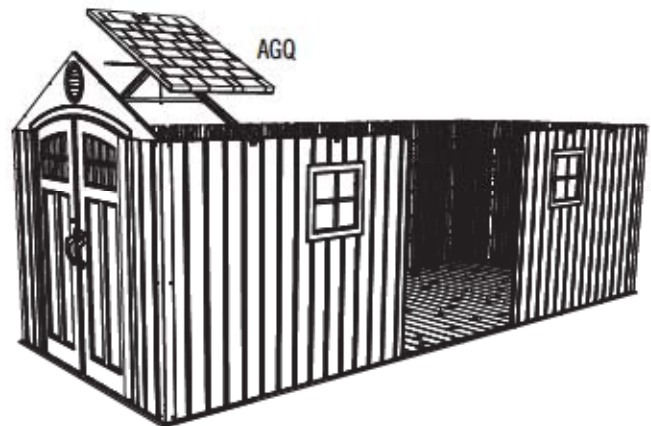
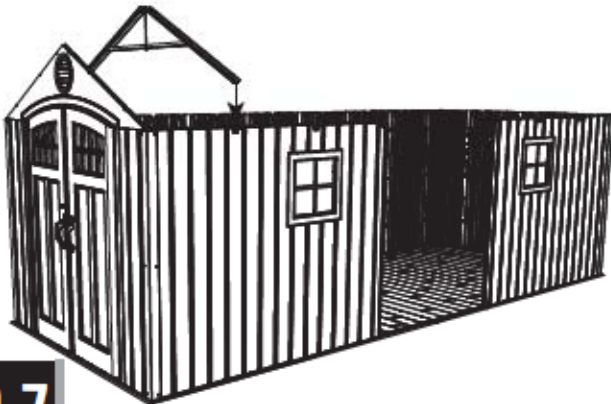

10.7

- Set the **Roof Panel (AGQ)** down onto the Wall Panel, Gable, and Truss. The groove at the bottom of the Roof Panel sets over the top of the Wall Panel. Ensure the alignment nub fits into the notch in the Truss.
- Mettre le **panneau de toit (AGQ)** dans le panneau mural, le pignon, et la ferme. Mettez la rainure au bord inférieur du panneau de toit sur la partie supérieure du panneau mural. Mettez la petite bosse d'alignement dans l'encoche de la ferme.
- Colocar el **panel de tejado (AGQ)** en el panel de pared, la fachada, y la cercha. Colocar la ranura a lo largo del borde inferior del panel de tejado sobre la parte superior del panel de pared. Encajar el bulto de alineamiento en la muesca en la cercha.

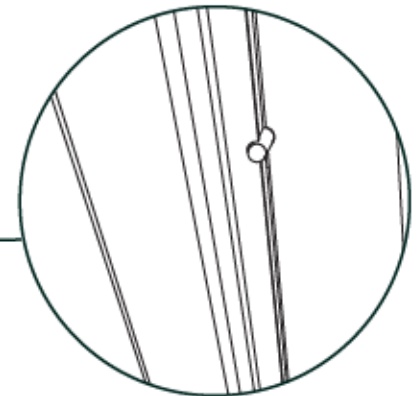
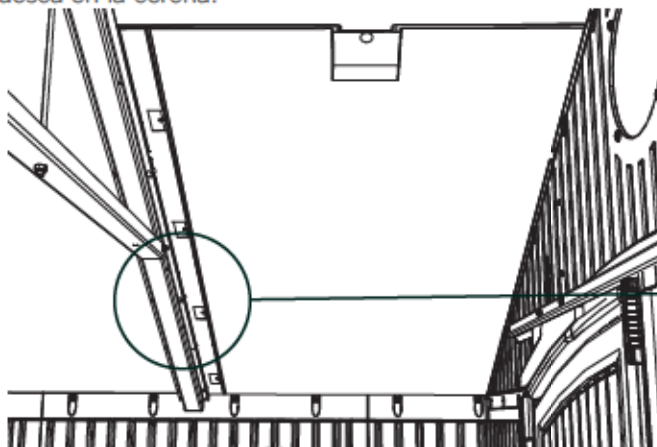

► SECTION 10 (CONTINUED) / SECTION 10 (SUITE) / SECCIÓN 10 (CONTINUACIÓN)

TOOLS AND PARTS REQUIRED / OUTILS ET QUINCAILLERIE REQUIS / INSTRUMENTAL Y HERRAJE REQUERIDOS

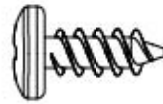

ADZ (x8)

10.8

- Align the four holes in the Wall Panel with those at the bottom of the Roof Panel, and insert four (4) **Screws (ADZ)** to secure the Panel in place.
- Aligner les quatre trous dans le panneau mural avec ceux au bord inférieur du panneau de toit, et insérer quatre (4) **vis (ADZ)** pour attacher le panneau en place.
- Alinear los cuatro agujeros en el panel de pared con los al borde inferior del panel de tejado, e introducir cuatro (4) **tornillos (ADZ)** para sujetarlo en su lugar.

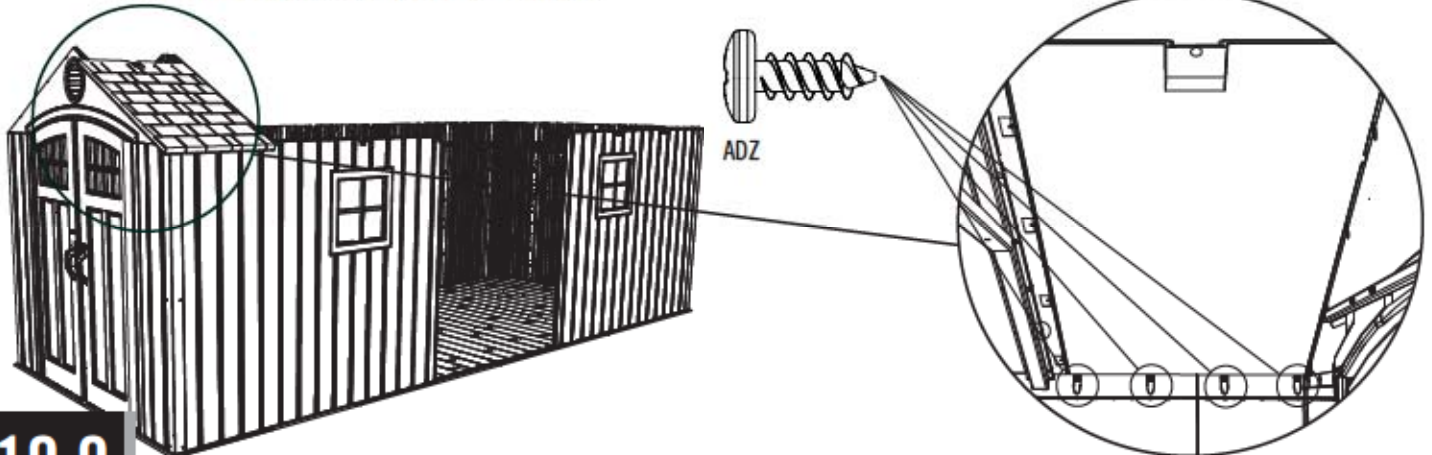

10.9

- Insert the first two **Screws (ADZ)** through the Gable and into the Roof Panel and the first two (2) **Screws (ADZ)** through the Truss and the Roof Panel at the locations shown.
- Insérer les premières deux **vis (ADZ)** à travers le pignon et dans le panneau de toit et les premières deux (2) **vis (ADZ)** à travers la ferme et dans le panneau de toit aux emplacements illustrés.
- Introducir los primeros dos **tornillos (ADZ)** por la fachada y dentro del panel de tejado y los primeros dos (2) **tornillos (ADZ)** por el armazón y dentro del panel de tejado a las ubicaciones indicadas.

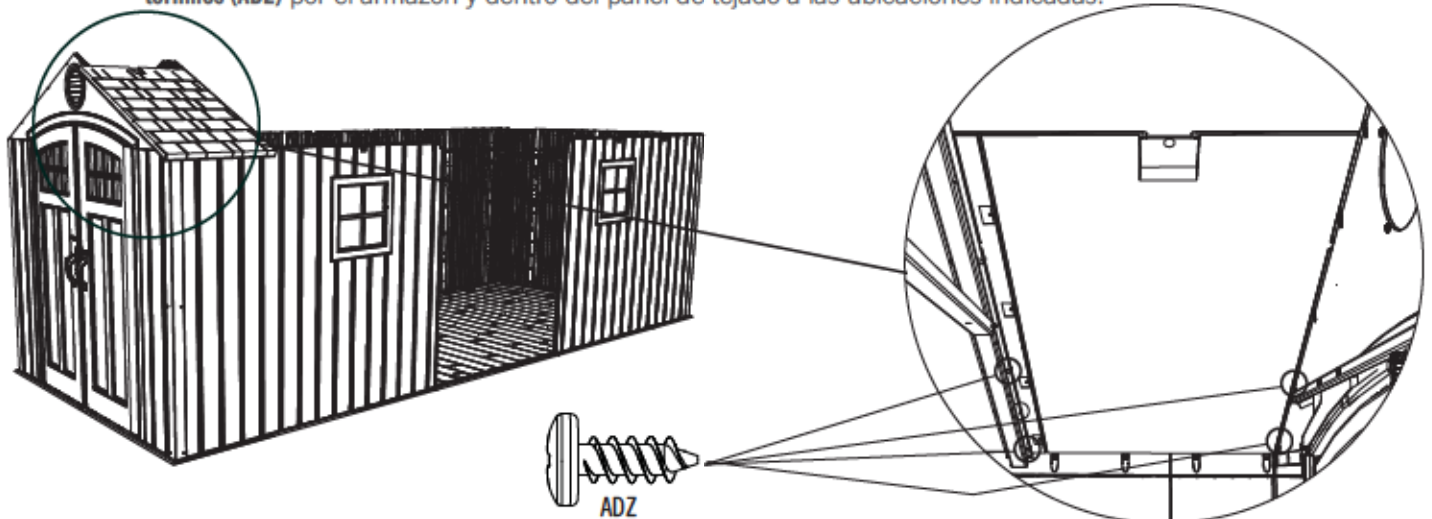

► SECTION 10 (CONTINUED) / SECTION 10 (SUITE) / SECCIÓN 10 (CONTINUACIÓN)

TOOLS AND PARTS REQUIRED / OUTILS ET QUINCAILLERIE REQUIS / INSTRUMENTAL Y HERRAJE REQUERIDOS

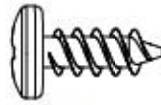

ADZ (x14)

10.10

- Insert the **Roof Support (AFL)** into the notches in the Gable and between the Truss and the Roof Panel. Insert three (3) more **Screws (ADZ)** to secure the Panel in place.
- Mettre le **support de toit (AFL)** dans les encoches dans le pignon et entre le panneau de toit et la ferme. Insérer trois (3) autres **vis (ADZ)** pour attacher le panneau en place.
- Insertar el **soporte de tejado (AFL)** en las muescas en la fachada y entre la cercha y el panel de tejado. Introducir tres (3) **tornillos (ADZ)** más para sujetar el panel en su lugar.

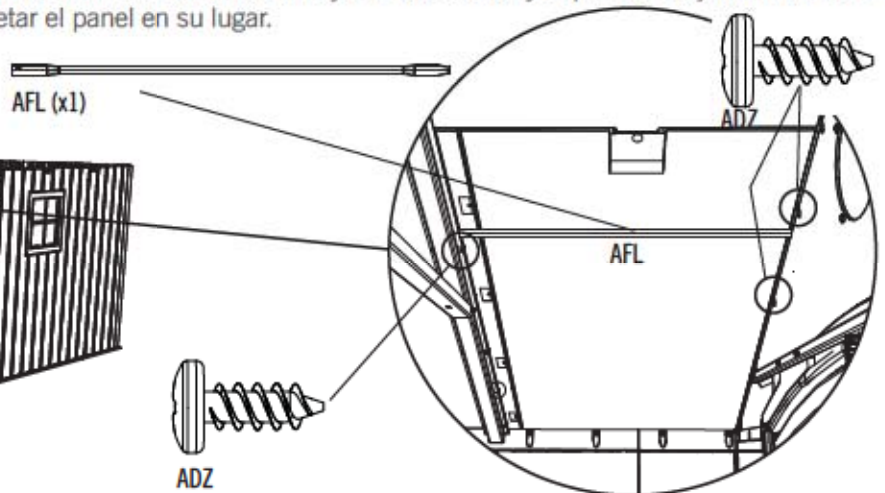
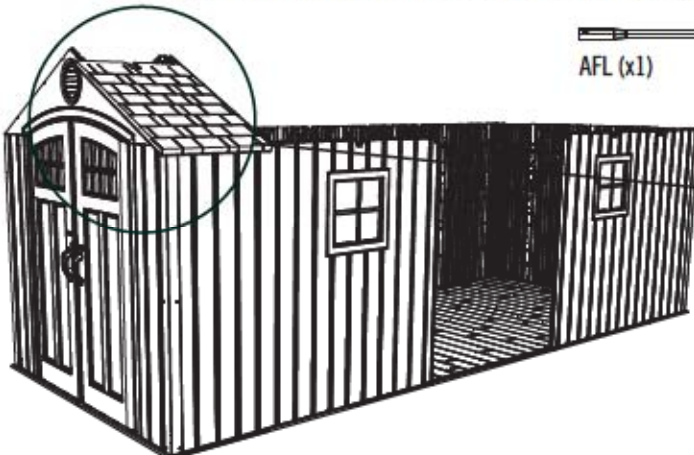

10.11

- Repeat steps 10.7–10.10 for the second front Roof Panel.
- Répéter les étapes 10.7 – 10.10 pour le deuxième panneau de toit avant.
- Repetir los pasos 10.7–10.10 para el segundo panel de tejado delantero.

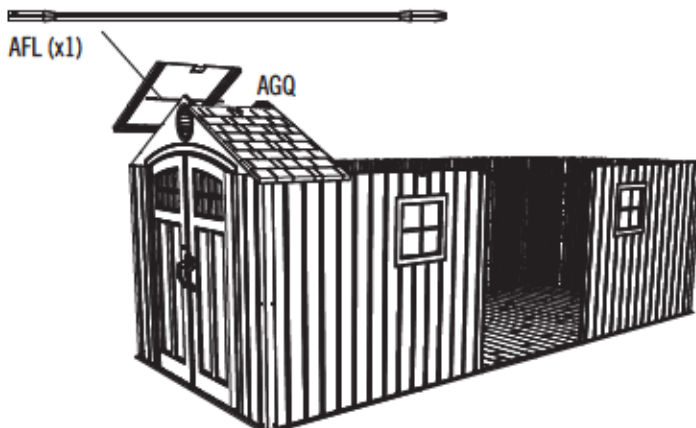

10.12

- Set the second Truss down into the notches on the Wall Panels.
- Mettre la deuxième ferme dans les encoches dans les panneaux muraux.
- Colocar la segunda cercha en las muescas en los paneles murales.

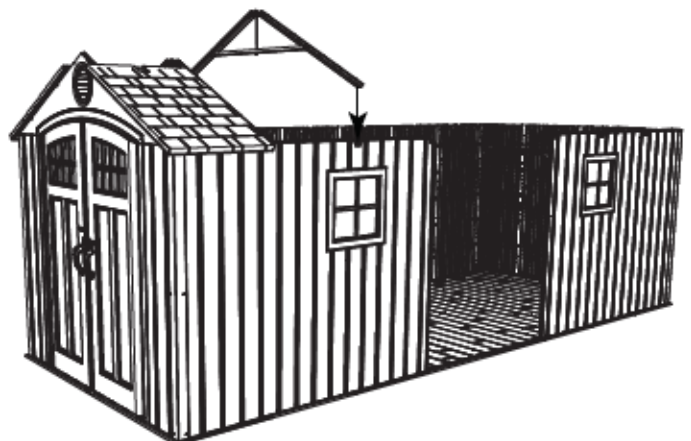

► SECTION 10 (CONTINUED) / SECTION 10 (SUITE) / SECCIÓN 10 (CONTINUACIÓN)

TOOLS AND PARTS REQUIRED / OUTILS ET QUINCAILLERIE REQUIS / INSTRUMENTAL Y HERRAJE REQUERIDOS

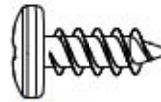

ADZ (x40)

10.13

- Attach the third and fourth **Roof Panels (AGQ)** similar to the way you attached the first two. Secure with ten (10) **Screws (ADZ)** each.
- Mettre les troisième et quatrième **panneaux de toit (AGQ)** dans une manière similaire aux premiers deux. Attacher-les bien à l'aide de dix (10) **vis (ADZ)** chaque un.
- Colocar los tercer y cuarto **paneles de tejado (AGQ)** en manera similar a los primeros dos. Sujetarlos usando diez (10) **tornillos (ADZ)** cada uno.

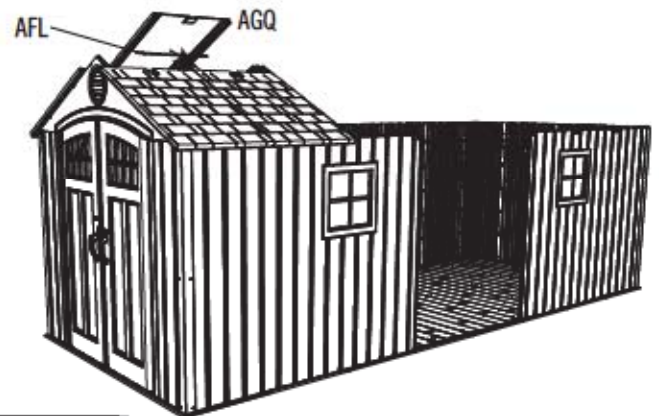
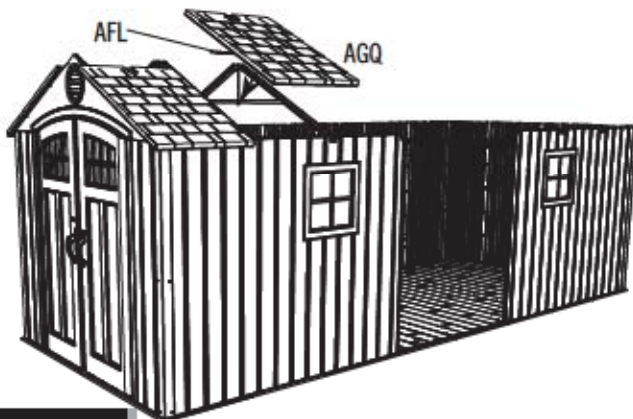

10.14

- Set the third Truss down into the notches on the Wall Panels. **This Truss has a notch on the end of only one Truss Channel—it goes toward the front.**
- Mettre la troisième ferme dans les encoches dans les panneaux muraux. **Cette ferme a une encoche dans l'extrémité d'un Canal seulement — cette encoche va vers la partie avant.**
- Colocar la tercera cercha en las muescas en los paneles murales. **Esta cercha tiene una muesca en el extremo de sólo uno de los Canales; va hacia la parte delantera.**

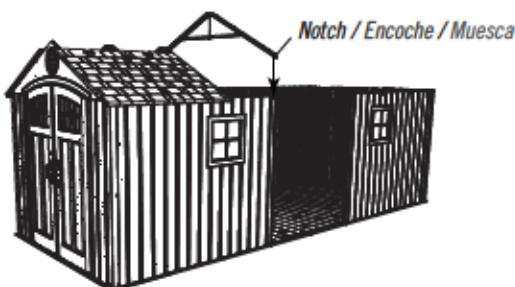

10.15

- Attach the fifth and sixth **Roof Panels (AGQ & AHB)** similar to the way you attached the second two. Secure with ten (10) **Screws (ADZ)** each.
- Mettre les cinquième et sixième **panneaux de toit (AGQ et AHB)** dans une manière similaire aux deuxième deux. Attacher-les bien à l'aide de dix (10) **vis (ADZ)** chaque un.
- Colocar los quinto y sexto **paneles de tejado (AGQ y AHB)** en manera similar a los segundos dos. Sujetarlos usando diez (10) **tornillos (ADZ)** cada uno.



► SECTION 10 (CONTINUED) / SECTION 10 (SUITE) / SECCIÓN 10 (CONTINUACIÓN)

TOOLS AND PARTS REQUIRED / OUTILS ET QUINCAILLERIE REQUIS / INSTRUMENTAL Y HERRAJE REQUERIDOS

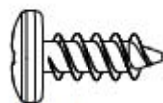

ADZ (x42)

10.16

- Attach a Side Gable to the Shed using fourteen (14) **Screws (ADZ)**.
- Fixer un pignon latéral à l'abri à l'aide de quatorze (14) **vis (ADZ)**.
- Fijar una fachada lateral a la caseta usando catorce (14) **tornillos (ADZ)**.

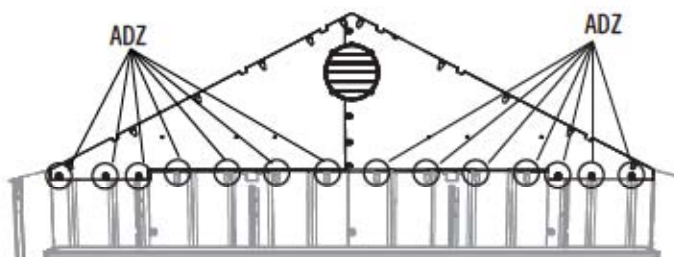

10.17

- Attach the Panels to the right side of the shed in the same way you did to the left. **The Truss closest to the entryway has a notch on the end of only one Truss Channel. It goes toward the front.**
- Fixer bien les panneaux de toit au côté droit de l'abri de la même manière qu'au côté gauche. **La ferme la plus proche à l'entrée comporte une encoche dans l'extrémité d'un canal seulement. Cette encoche va vers la partie avant.**
- Fijar los paneles de tejado al lado derecho de la caseta de igual manera que al lado izquierdo. **La cercha más próxima a la entrada tiene una muesca en el extremo de sólo uno de los canalones. La muesca va hacia la parte delantera.**



Notch / Encoche / Muesca

10.18

- Place the back of the Center Truss into the notch on the center rear Wall Panel. Then, lift the front of the Truss up so the ends of the Roof Support Tube touch the Side Trusses.
- Mettre l'extrémité arrière de la ferme centrale dans l'encoche sur le panneau mural arrière central. Ensuite, soulever l'extrémité avant de la ferme pour que les extrémités du tube de support touchent les fermes latérales.
- Colocar el extremo trasero de la cercha central en la muesca en el panel de tejado central trasero. Entonces, levantar el extremo delantero de la cercha para arriba para que los extremos del tubo de soporte hagan contacto con las cerchas laterales.

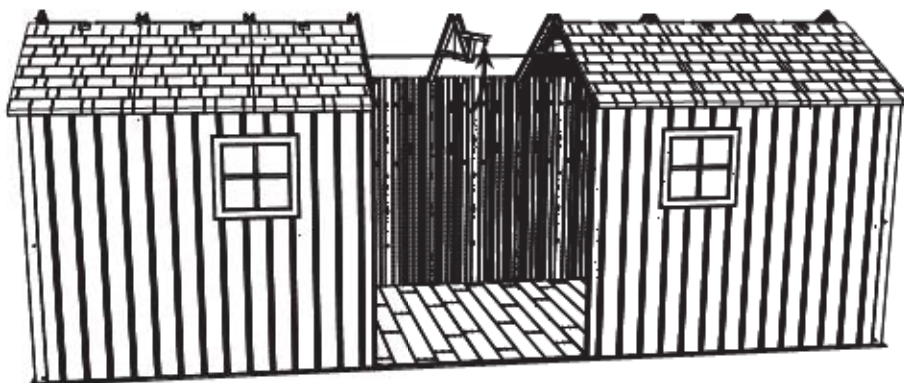

► SECTION 10 (CONTINUED) / SECTION 10 (SUITE) / SECCIÓN 10 (CONTINUACIÓN)

TOOLS AND PARTS REQUIRED / OUTILS ET QUINCAILLERIE REQUIS / INSTRUMENTAL Y HERRAJE REQUERIDOS



3/8 in/po
(10 mm)



DTV (x2)



AEE (x2)



CXK (x2)



AHP (x2)

10.19

- Secure the ends of the Support Tube to the underside of the Trusses using the hardware included.
- Attacher bien les extrémités du tube de support à la partie inférieure des fermes à l'aide de la quincaillerie incluse.
- Sujetar los extremos del tubo de soporte al parte inferior de las cerchas laterales usando el herraje incluido.

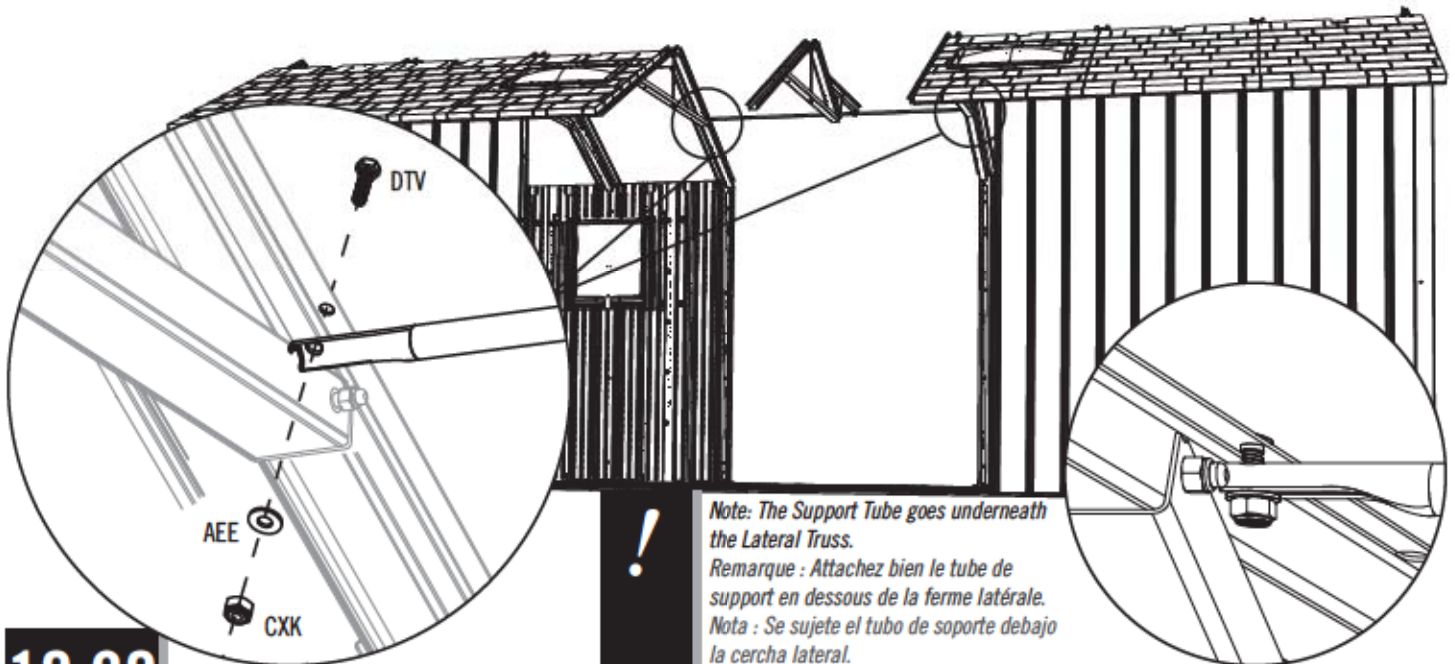

10.20

- Secure the Hinge Tubes to the Bushings as you did for steps 10.2 – 10.3.
- Attacher les tubes d'articulation aux bagues comme vous l'avez faits dans les étapes 10.2 – 10.3.
- Sujetar los tubos de articulación a los casquillos tal como lo hizo en los pasos 10.2 – 10.3.

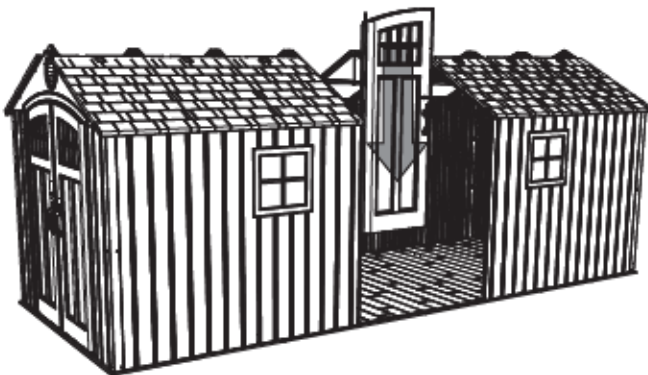

► SECTION 10 (CONTINUED) / SECTION 10 (SUITE) / SECCIÓN 10 (CONTINUACIÓN)

TOOLS AND PARTS REQUIRED / OUTILS ET QUINCAILLERIE REQUIS / INSTRUMENTAL Y HERRAJE REQUERIDOS



3/8 in/po
(10 mm)

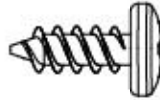

ADZ (x1)

10.21

- Slide the holes in the Entry Gable down over the two Hinge Tubes. **The ends of the Gable go in the Trusses.**
- Faire glisser les trous dans le pignon d'entrée sur les deux tubes. **Les extrémités du pignon vont dans les fermes.**
- Deslizar los agujeros en la fachada de entrada sobre los dos tubos. **Los extremos de la fachada van dentro de las cerchas.**



10.22

- Set the end of the Center Truss onto the notch in the Front Gable Panel as shown.
- Mettre l'extrémité de la ferme centrale dans l'encoche dans le pignon avant comme illustré.
- Colocar el extremo de la cercha central en la muesca en la fachada delantera como se muestra.

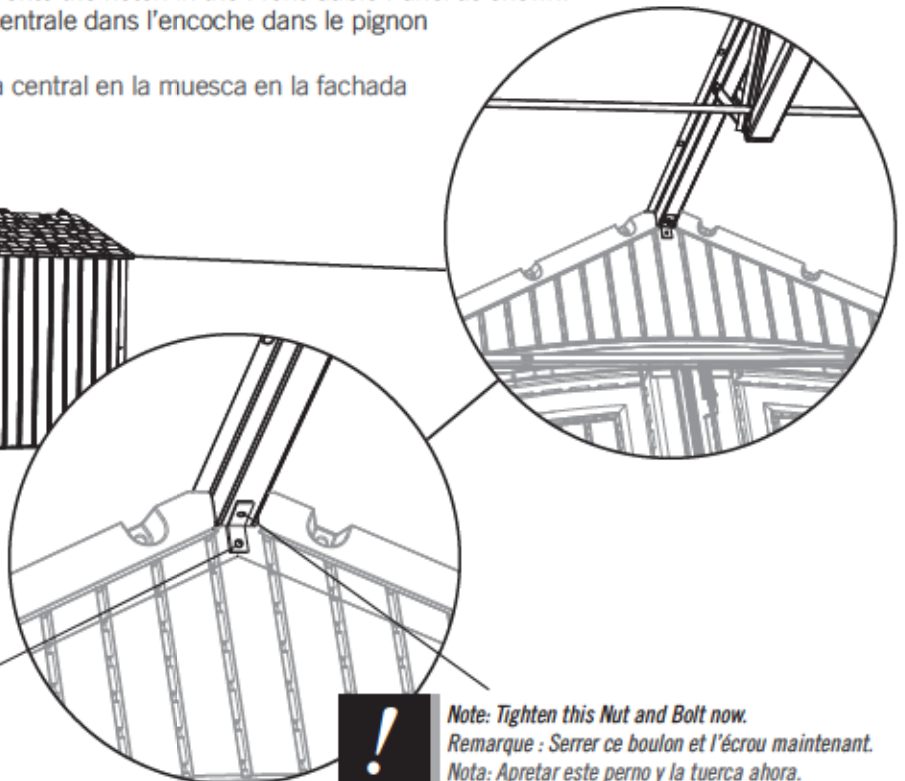
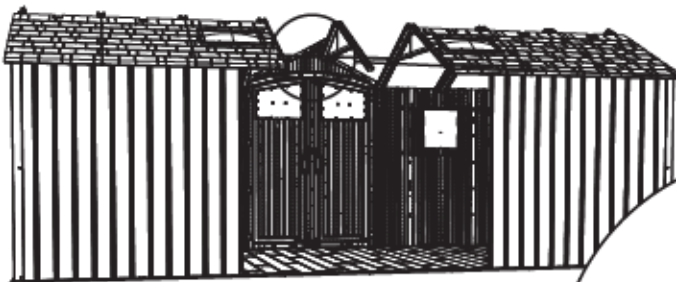

ADZ

! *Note: Tighten this Nut and Bolt now.
Remarque : Serrer ce boulon et l'écrou maintenant.
Nota: Apretar este perno y la tuerca ahora.*

► SECTION 10 (CONTINUED) / SECTION 10 (SUITE) / SECCIÓN 10 (CONTINUACIÓN)

TOOLS AND PARTS REQUIRED / Outils et quincaillerie requis / Instrumental y herraje requeridos

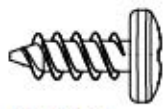

ADZ (x20)



ECS (x1)



ECR (x1)



ADK (x2)



BZA (x2)



AEE (x4)

10.23

- Attach the two center, rear Roof Panels using only one Roof Support per Panel.
- Attacher les deux panneaux de toit arrières centraux en utilisant un seul support de toit pour chaque panneau.
- Sujetar los dos paneles de tejado traseros centrales usando sólo un soporte de tejado por panel.



AFL (x2)

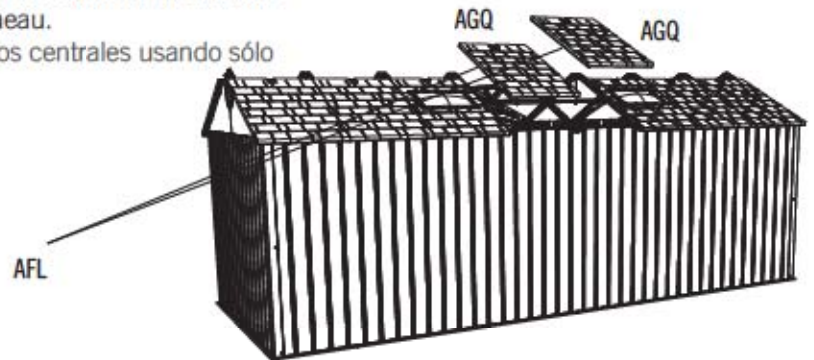

10.24

- Insert the **Right Drainage Plate (ECS)** into the Right Lateral Truss, and align the notch in the Plate with the first hole in the Truss as shown. Secure with the hardware included. **Only tighten by hand for now.**
- Insérer la **plaque de drainage droite (ECS)** dans la ferme latérale droite, et aligner l'encoche dans la plaque avec le premier trou dans la ferme comme illustré. Attacher-la bien à la ferme à l'aide de la quincaillerie incluse. **Ne serrer qu'à la main en ce moment.**
- Insertar la **placa derecha para el drenaje (ECS)** dentro de la cercha lateral derecho, y alinear la muesca en la placa con el primer agujero en la cercha. Sujetarla a la cercha usando el herraje incluido. **Apretar sólo a mano en este momento.**



Note: Repeat this step for the Left Drainage Plate (ECR).

Remarque : Répéter cette étape pour la plaque de drainage gauche (ECR).

Nota: Repetir este paso para la placa izquierda para el drenaje (ECR).

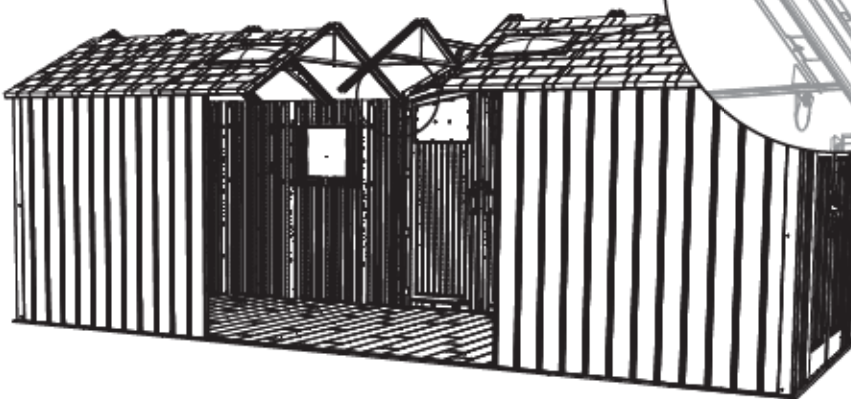
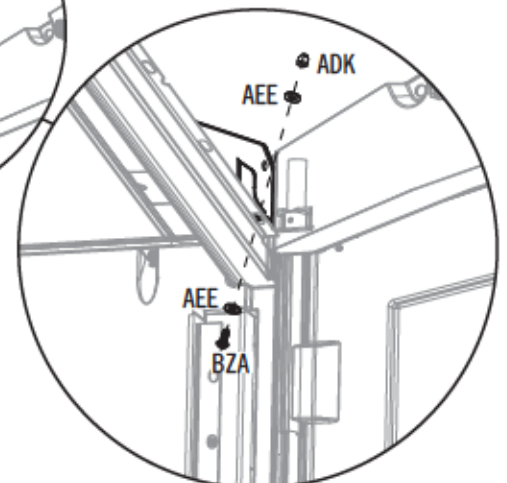
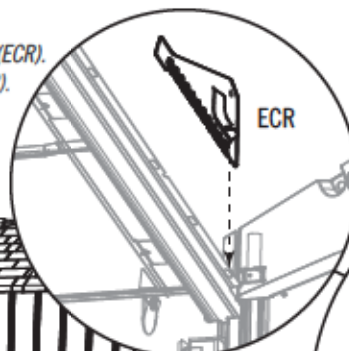

► SECTION 10 (CONTINUED) / SECTION 10 (SUITE) / SECCIÓN 10 (CONTINUACIÓN)

TOOLS AND PARTS REQUIRED / OUTILS ET QUINCAILLERIE REQUIS / INSTRUMENTAL Y HERRAJE REQUERIDOS



3/8 in/po
(10 mm)

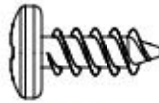

ADZ (x14)

10.25

- Fold the ends of the **Large Angled Roof Panel (DRA)** and set it down onto the shed as shown. Secure the Panel to the Entry Gable and Center Truss with twelve (12) **Screws (ADZ)** at the locations shown.
- Plier les extrémités du **panneau de toit angulaire grand (DRA)** et mettre-le sur l'abri comme illustré. Attacher-le bien au pignon et à la ferme centrale à l'aide de douze (12) **vis (ADZ)** aux emplacements indiqués.
- Doblar los extremos del **panel de tejado angular grande (DRA)** y colocarlo en la caseta como se muestra. Sujeterlo a la fachada y la cercha central usando doce (12) **tornillos (ADZ)** a las ubicaciones indicadas.



Note: Fold these ends upward before installing.
Remarque : Plier ces rabats en haut avant d'installer.
Nota: Doblar estas solapas hacia arriba antes de instalar.

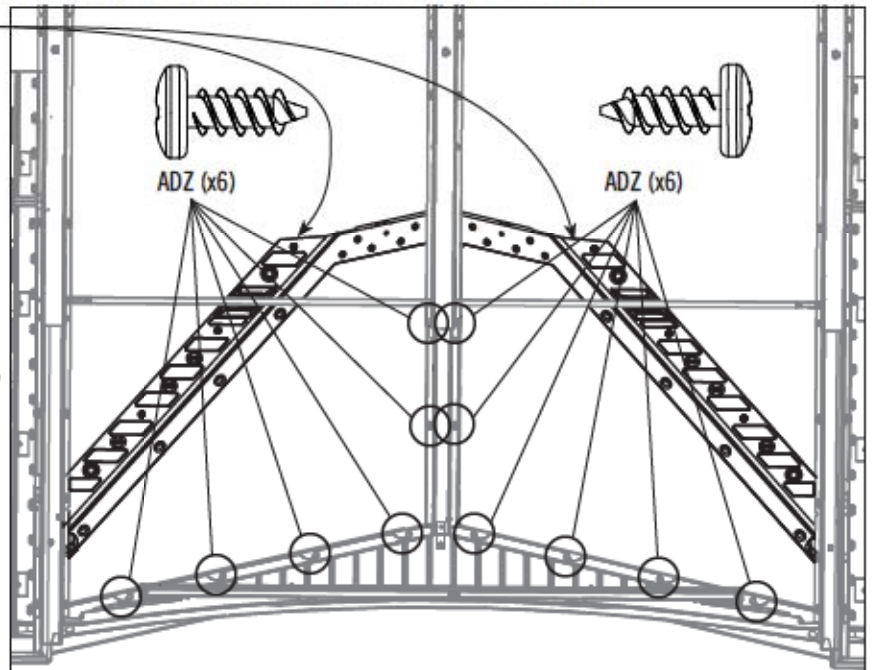

10.26

- Secure the Drainage Plate from step 10.24 to the Roof at the location shown.
- Attacher la plaque de drainage des étapes 10.24 au toit à l'emplacement illustré.
- Sujetar la placa de drenaje de los pasos 10.24 al tejado a la ubicación ilustrada.

- **Tighten the Nut on the Drainage Plate now.**
- **Serrer l'écrou dans la plaque de drainage.**
- **Apretar la tuerca en la placa de drenaje ahora.**

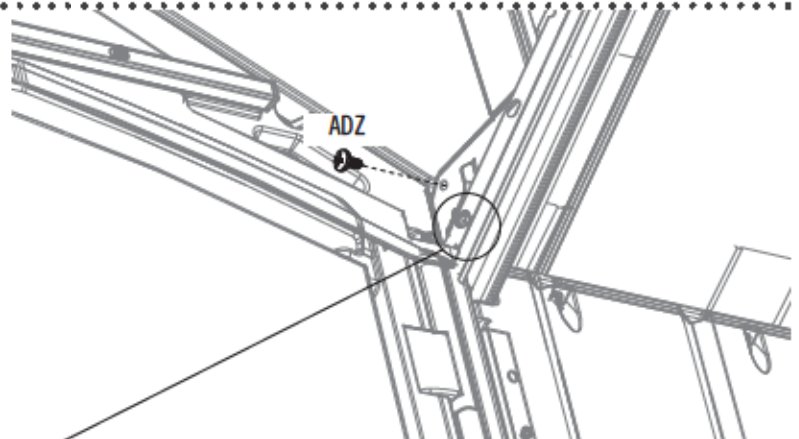

Note: Repeat this step for the other Drainage Plate.
Remarque : Répéter cette étape pour l'autre plaque de drainage.
Nota: Repetir este paso para la otra placa de drenaje.

► SECTION 10 (CONTINUED) / SECTION 10 (SUITE) / SECCIÓN 10 (CONTINUACIÓN)

TOOLS AND PARTS REQUIRED / Outils et quincaillerie requis / Instrumental y herraje requeridos

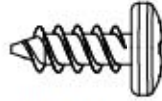

ADZ (x20)

10.27

- An adult must apply a downward pressure on **Panel (DRB)** while another inserts these **Screws (ADZ)**.
- Une adulte doit appliquer pression sur le **panneau (DRB)** pendant qu'autre insère ces **vis (ADZ)**.
- Un adulto debe aplicar una presión de arriba en el **panel (DRB)** mientras que otro introduce estos tornillos (ADZ).

DRB

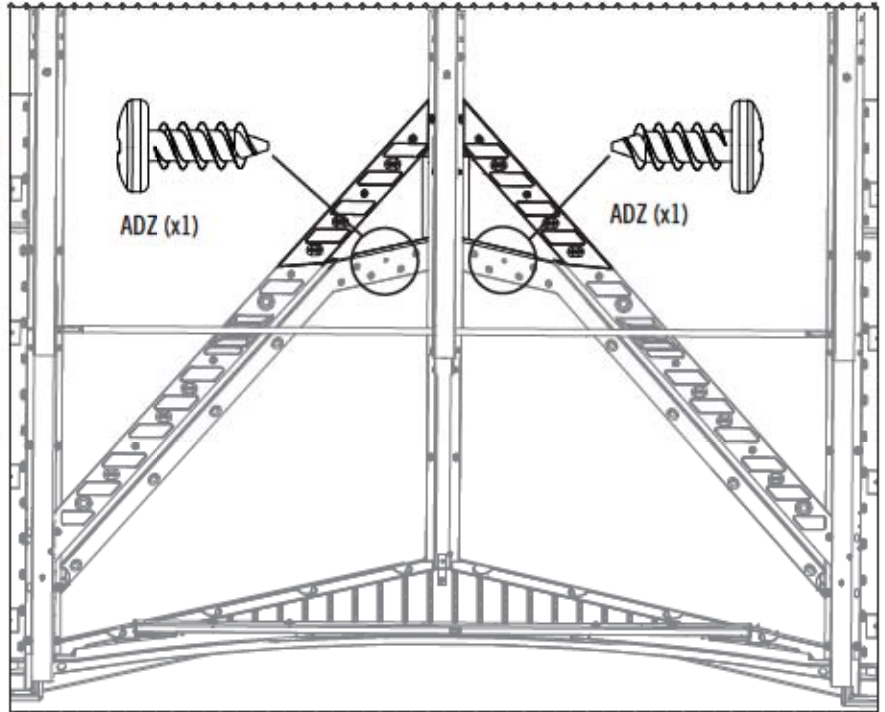

10.28

- An adult must apply a downward pressure on **Panels (BDS & BDR)** while another inserts these **Screws (ADZ)**.
- Une adulte doit appliquer pression sur les **panneaux (BDS et BDR)** pendant qu'autre insère ces **vis (ADZ)**.
- Un adulto debe aplicar una presión de arriba en los **paneles (BDS y BDR)** mientras que otro inserta estos tornillos (ADZ).

BDS BDR

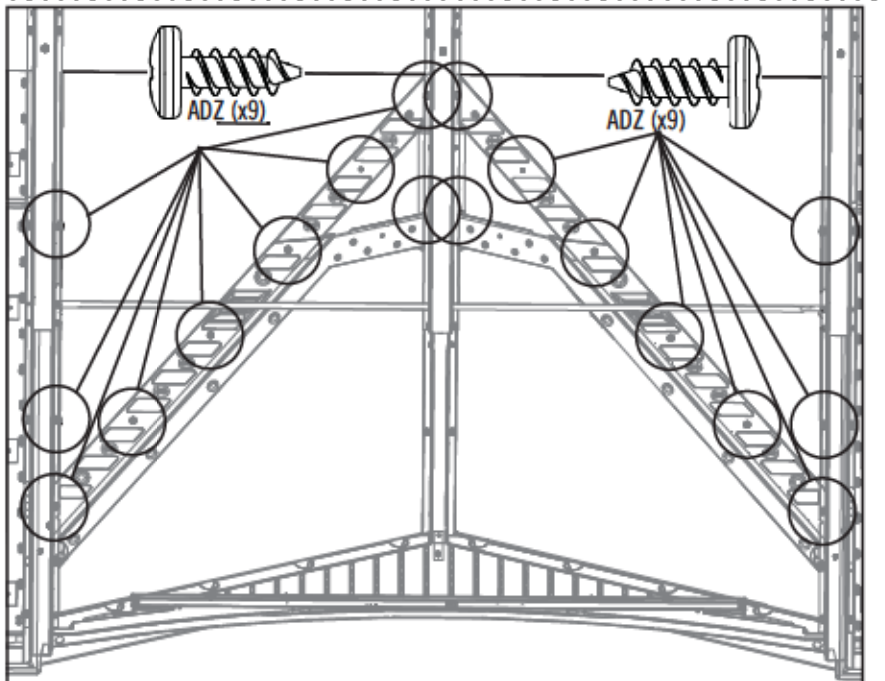
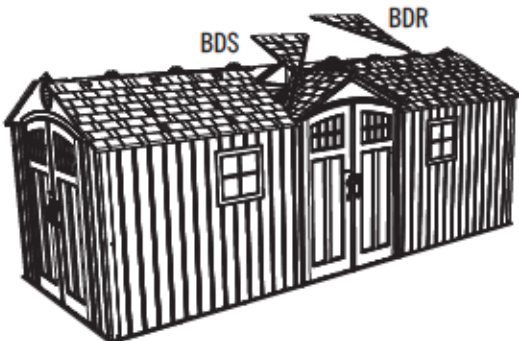

► SECTION 10 (CONTINUED) / SECTION 10 (SUITE) / SECCIÓN 10 (CONTINUACIÓN)

TOOLS AND PARTS REQUIRED / OUTILS ET QUINCAILLERIE REQUIS / INSTRUMENTAL Y HERRAJE REQUERIDOS

10.29

- Insert the two **Center Roof Extension Panels (CVD)** into the **Skylight Connector (CVF)** as shown. Repeat this step 4 times (for a total of five).
- Insérer les deux **panneaux supplémentaires centraux de toit (CVD)** dans le **connecteur des lucarnes (CVF)** comme illustré. Répéter cette étape 4 fois (cinq fois au total).
- Insertar los dos **extensiones centrales de los paneles de tejado (CVD)** en el **conector de tragaluces (CVF)** como se muestra. Repetir este paso 4 veces (cinco veces en total).

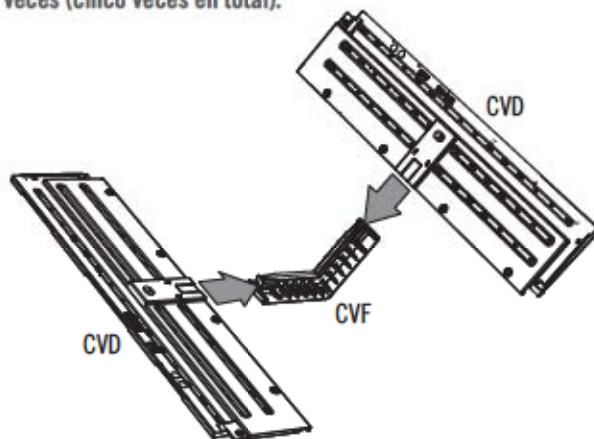

10.30

- Insert the ends of the two **Short Skylights (DQB)** into one Skylight Connector as shown.
- Insérer les extrémités des deux **lucarnes courtes (DQB)** dans un connecteur des lucarnes comme illustré.
- Insertar los extremos de los dos **tragaluces cortos (DQB)** en un conector de tragaluces como se muestra.

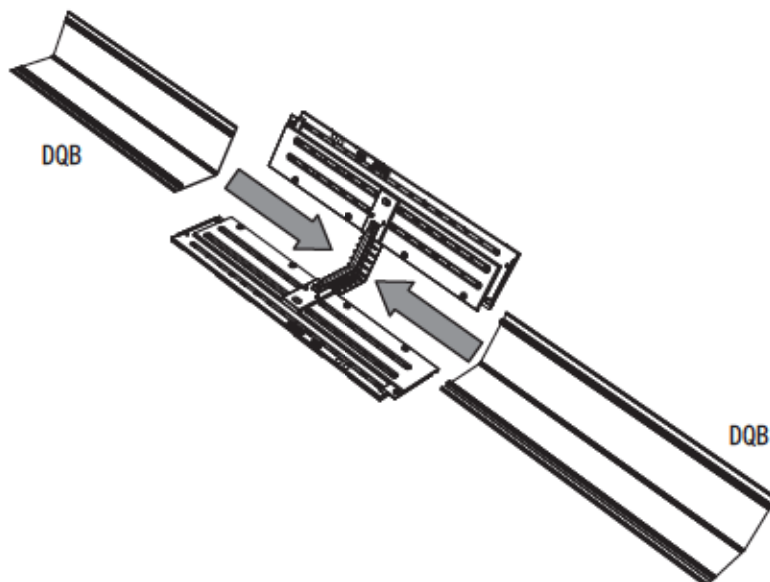

► SECTION 10 (CONTINUED) / SECTION 10 (SUITE) / SECCIÓN 10 (CONTINUACIÓN)

TOOLS AND PARTS REQUIRED / OUTILS ET QUINCAILLERIE REQUIS / INSTRUMENTAL Y HERRAJE REQUERIDOS

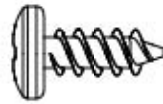

ADZ (x8)

10.31

- Secure the Skylights to the Extensions at the four points shown.
- Attacher les lucarnes aux panneaux supplémentaires aux quatre points indiqués.
- Sujetar los tragaluz a las extensiones a los cuatro puntos indicados.

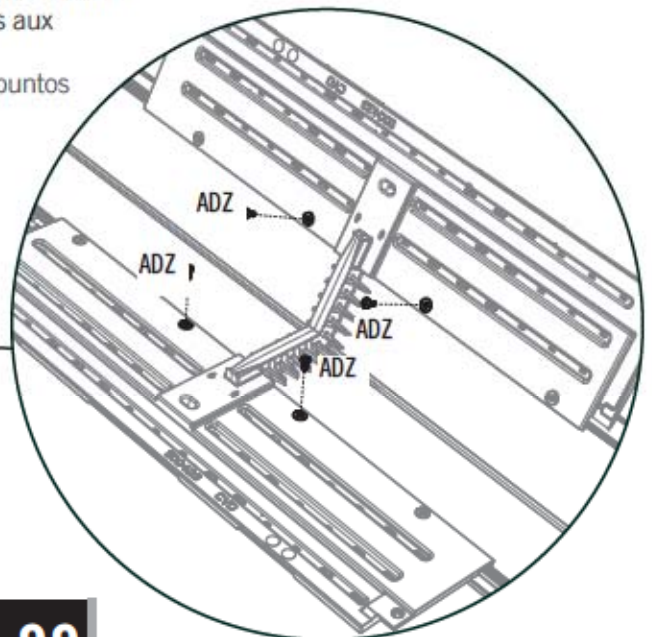
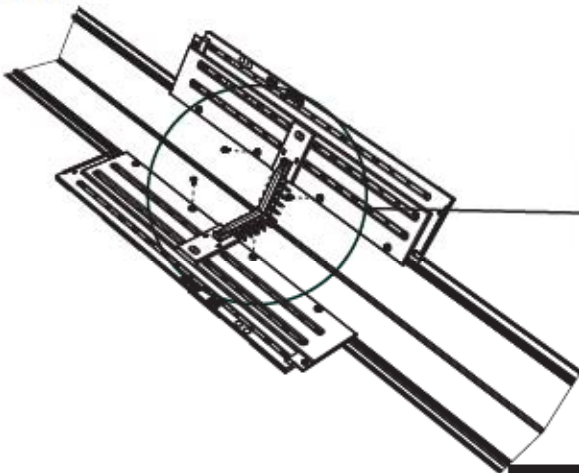

10.32

- Insert the end of the one **Short Skylight (DQB)** into the Skylight Connector as shown.
- Insérer l'extrémité d'une **lucarne courte (DQB)** dans le connecteur des lucarnes comme illustré.
- Insertar el extremo de un **tragaluz corto (DQB)** en el conector de tragaluz como se muestra.

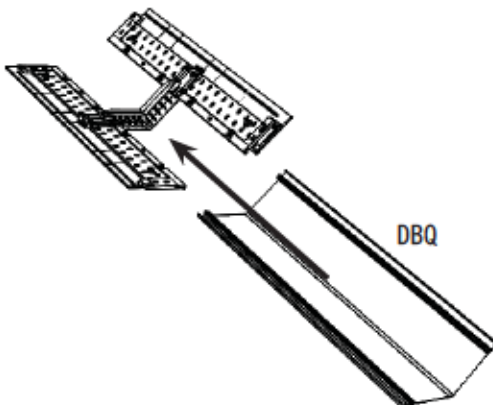

10.33

- Repeat the last step and secure the Skylights using two (2) Screws (ADZ) as shown.
- Répéter l'étape précédente et attacher les lucarnes à l'aide de deux (2) vis (ADZ) comme illustré.
- Repetir el paso anterior y sujetar los tragaluz usando dos (2) tornillos (ADZ) como se muestra.

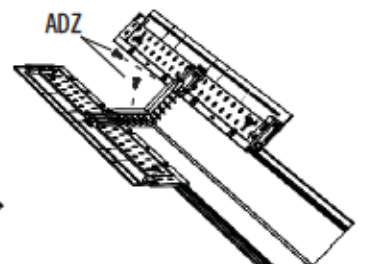
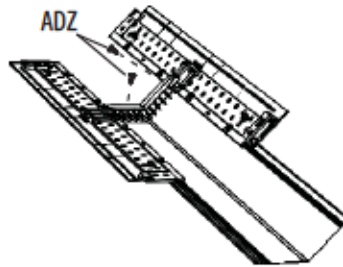

► SECTION 10 (CONTINUED) / SECTION 10 (SUITE) / SECCIÓN 10 (CONTINUACIÓN)

TOOLS AND PARTS REQUIRED / OUTILS ET QUINCAILLERIE REQUIS / INSTRUMENTAL Y HERRAJE REQUERIDOS

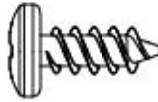

ADZ (x12)

10.34

- Slide the two Skylight Assemblies from step 10.33 to the Connector and Extensions from step 10.30.
- Faire glisser les deux montages des lucarnes des étapes 10.3 au connecteur et aux panneaux supplémentaires de l'étape 10.30.
- Deslizar los dos conjuntos de tragaluces del paso 10.33 al conector y las extensiones del paso 10.30.

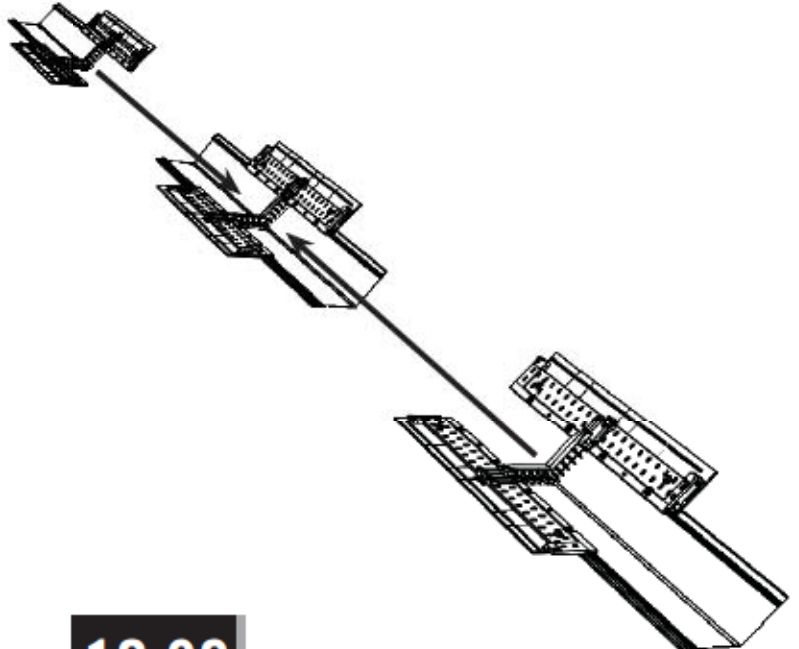

10.35

- Secure with six (6) Screws (ADZ).
- Attacher-les à l'aide de six (6) vis (ADZ).
- Sujetarlos con seis (6) tornillos (ADZ).

No screw in these holes yet / Aucune vis déjà dans ces trous / Ningún tornillo ya en estos agujeros

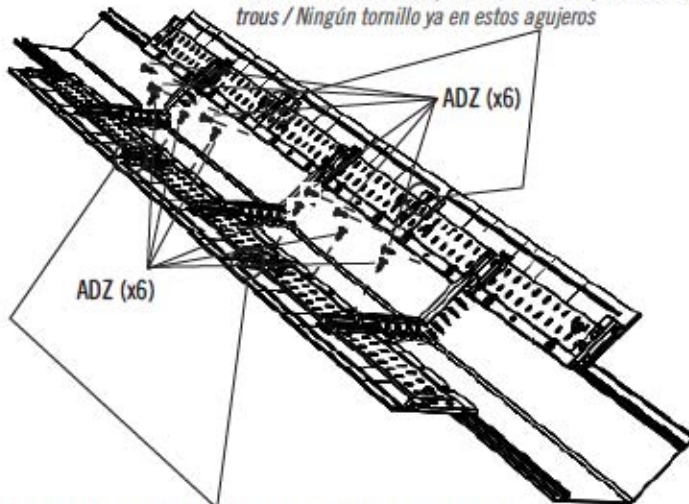

No screw in these holes yet / Aucune vis déjà dans ces trous / Ningún tornillo ya en estos agujeros

10.36

- Slide the last two Assemblies from step 10.29 over the ends of the Skylights.
- Faire glisser les dernières deux montages de l'étape 10.29 sur les extrémités des lucarnes.
- Deslizar los últimos dos conjuntos del paso 10.29 sobre los extremos de los tragaluces.

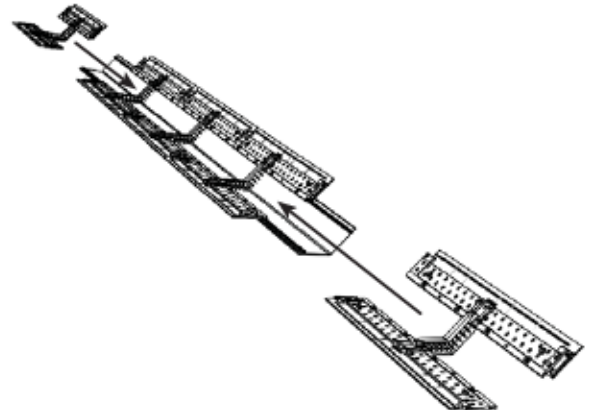

► SECTION 10 (CONTINUED) / SECTION 10 (SUITE) / SECCIÓN 10 (CONTINUACIÓN)

TOOLS AND PARTS REQUIRED / OUTILS ET QUINCAILLERIE REQUIS / INSTRUMENTAL Y HERRAJE REQUERIDOS

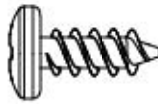

ADZ (x12)

10.37

- Secure the Skylight to the Panels using six (6) **Screws (ADZ)** at the locations shown.
- Attacher la lucarne aux panneaux à l'aide de six (6) **vis (ADZ)** aux emplacements indiqués.
- Sujetar el tragaluz a los paneles usando seis (6) **tornillos (ADZ)** a las ubicaciones indicadas.

! *Note: Repeat this step for the other end.*
Remarque : Répéter cette étape pour l'autre extrémité.
Nota: Repetir este paso para el otro extremo.

*No screw in these holes yet / Aucune vis déjà dans ces trous /
 Ningún tornillo ya en estos agujeros*

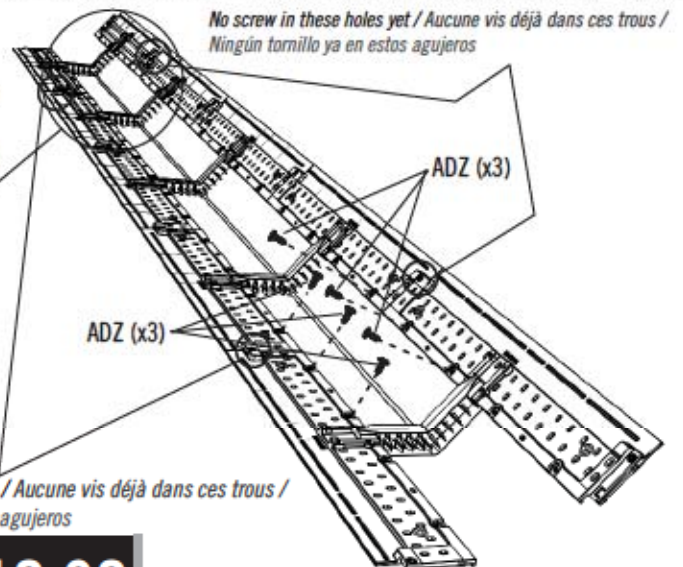

10.38

- Slide the two **Long Skylights (CVA)** into the Assembly.
- Faire glisser les deux **lucarnes longues (CVA)** dans le montage.
- Deslizar los dos **tragaluces largos (CVA)** en el conjunto.

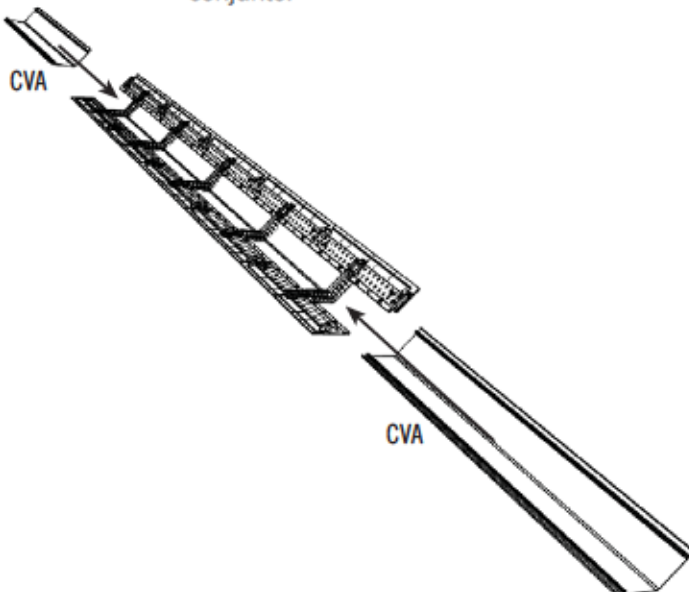

10.39

- Attach the **Long Roof Extensions (CVC & CVE)** to the Assembly.
- Attacher les **panneaux de toit supplémentaires longs (CVC et CVE)** au montage.
- Sujetar las **extensiones de tejado largas (CVC y CVE)** al conjunto.

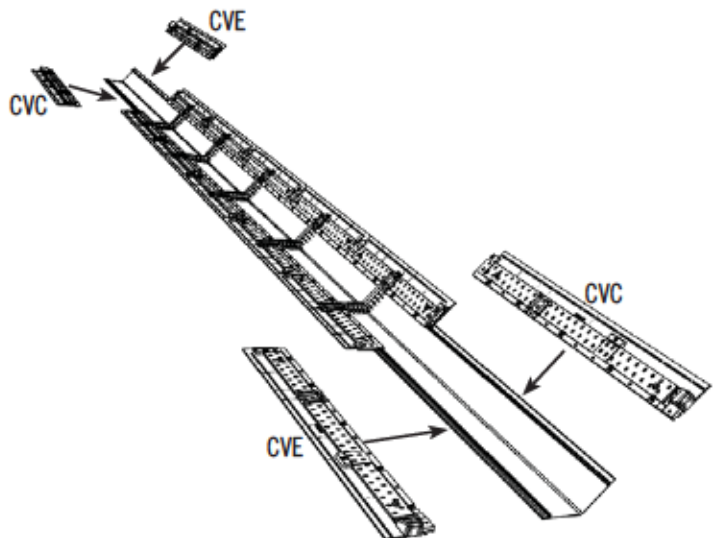

► SECTION 10 (CONTINUED) / SECTION 10 (SUITE) / SECCIÓN 10 (CONTINUACIÓN)

TOOLS AND PARTS REQUIRED / OUTILS ET QUINCAILLERIE REQUIS / INSTRUMENTAL Y HERRAJE REQUERIDOS

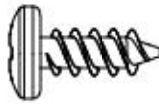

ADZ (x56)

10.40

- Secure the Long Roof Extensions to the Skylight Assembly using fourteen (14) **Screws (ADZ)**.
- Attacher les panneaux de toit supplémentaires au montage de lucarne à l'aide de quatorze (14) **vis (ADZ)**.
- Sujetar las extensiones del panel de tejado al conjunto del tragaluz usando catorce (14) **tornillos (ADZ)**.

Note: Repeat this step for the other end.

Remarque : Répéter cette étape pour l'autre extrémité.

Nota: Repetir este paso para el otro extremo.

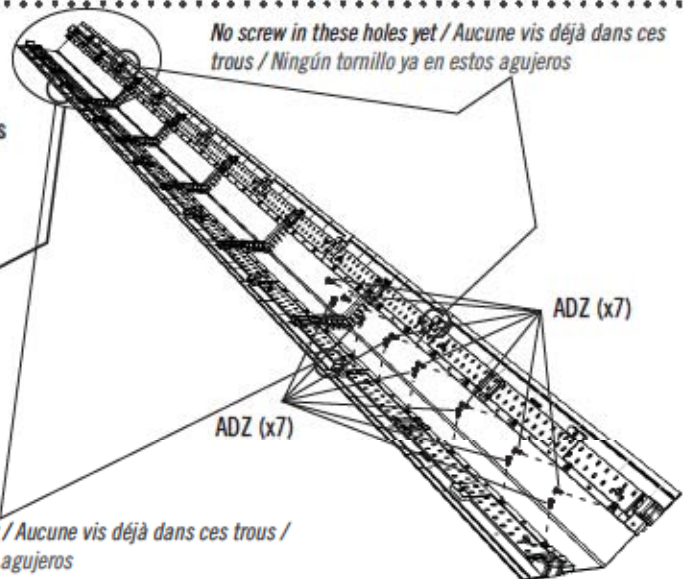

10.41



- Set the five Skylight Connectors down inside the five center-most Trusses. **The center Skylight Connector should be inside the center Truss.** Secure the Skylight to the Trusses with four (4) **Screws (ADZ)** at the locations indicated for each Truss.
- Mettre les cinq connecteurs des lucarnes dedans les cinq fermes centrales. **Le connecteur des lucarnes central doit être placé dans la ferme centrale.** Attacher les lucarnes aux fermes à l'aide de quatre (4) **vis (ADZ)** aux emplacements indiqués pour chaque ferme.
- Colocar los cinco conectores de tragaluz dentro de las cinco cerchas centrales. **El conector de tragaluz central debe situarse dentro de la cercha central.** Sujetar los tragaluces a las cerchas usando cuatro (4) **tornillos (ADZ)** a las ubicaciones indicadas para cada cercha.



► SECTION 10 (CONTINUED) / SECTION 10 (SUITE) / SECCIÓN 10 (CONTINUACIÓN)

TOOLS AND PARTS REQUIRED / OUTILS ET QUINCAILLERIE REQUIS / INSTRUMENTAL Y HERRAJE REQUERIDOS

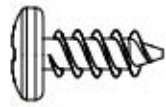

ADZ (x24)



CUZ (x4)

10.42



- Connect the Roof Panel Extensions to the Roof Panels and Gables at the locations shown.
- Attacher les panneaux de toit supplémentaires aux panneaux de toit et aux fermes aux emplacements indiqués.
- Sujetarlas las extensiones de los paneles de tejado a los paneles de tejado y las fachadas a las ubicaciones indicadas.

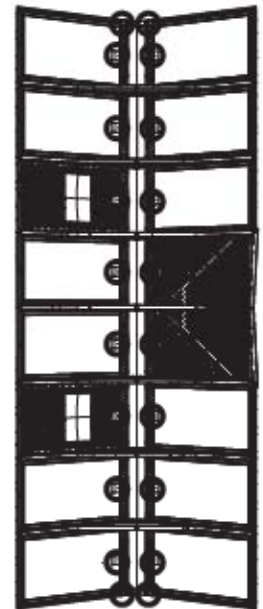
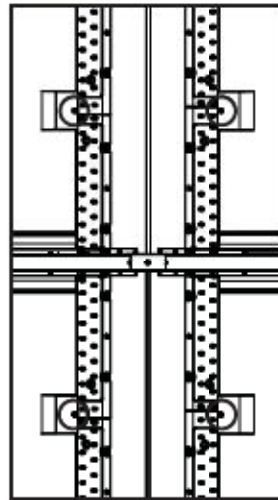

10.43

- Attach an **End Cap (CVB)** at each end, and secure at the locations shown.
- Mettre un **capuchon (CVB)** a chaque côté, et attacher-les aux emplacements illustrés.
- Colocar un **tapón (CVB)** a cada extremo, y sujetarlos a las ubicaciones indicadas.

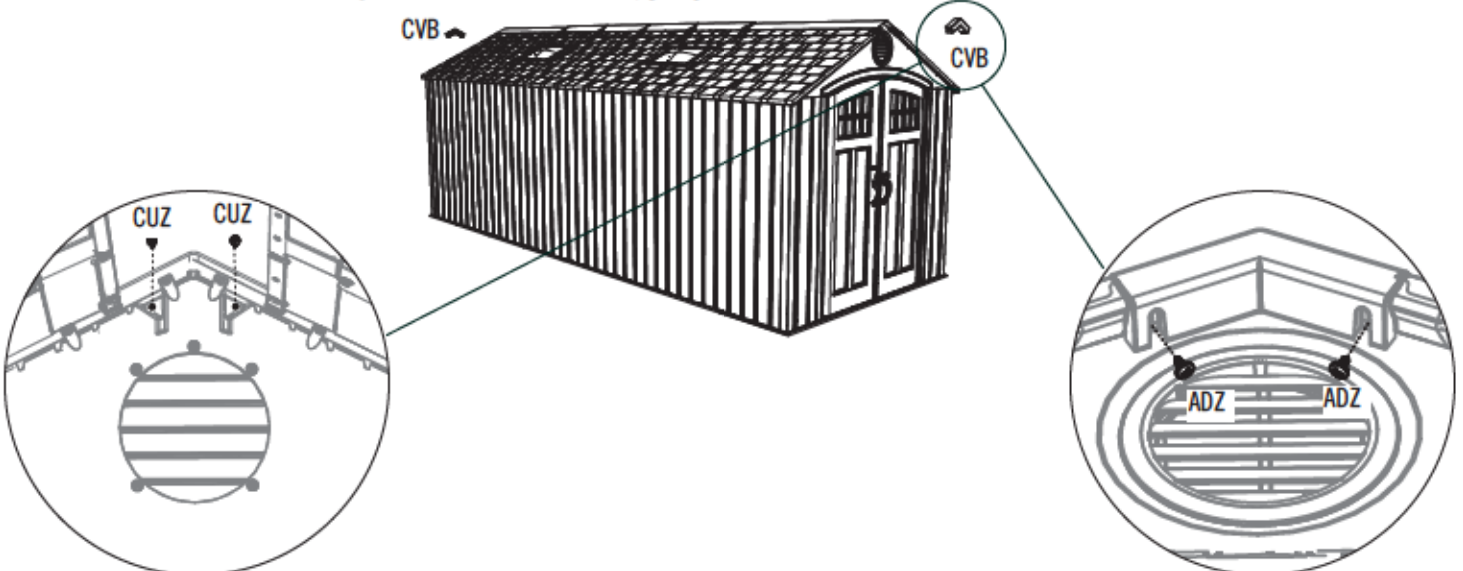

► SECTION 10 (CONTINUED) / SECTION 10 (SUITE) / SECCIÓN 10 (CONTINUACIÓN)

TOOLS AND PARTS REQUIRED / OUTILS ET QUINCAILLERIE REQUIS / INSTRUMENTAL Y HERRAJE REQUERIDOS

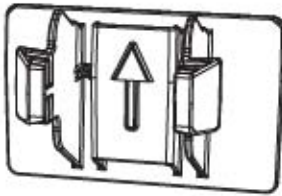

AXX (x2)



ADX (x4)

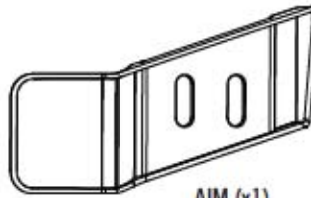

AIM (x1)

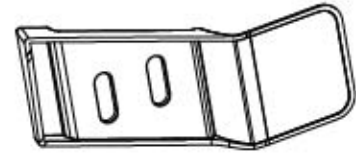

AIC (x1)

10.44

- Insert the **Clips (AXX)** with the "arrow" facing up.
- Insérer les **clips (AXX)** avec la « flèche » vers le haut.
- Insertar las **clips (AXX)** con la « flecha » hacia arriba.

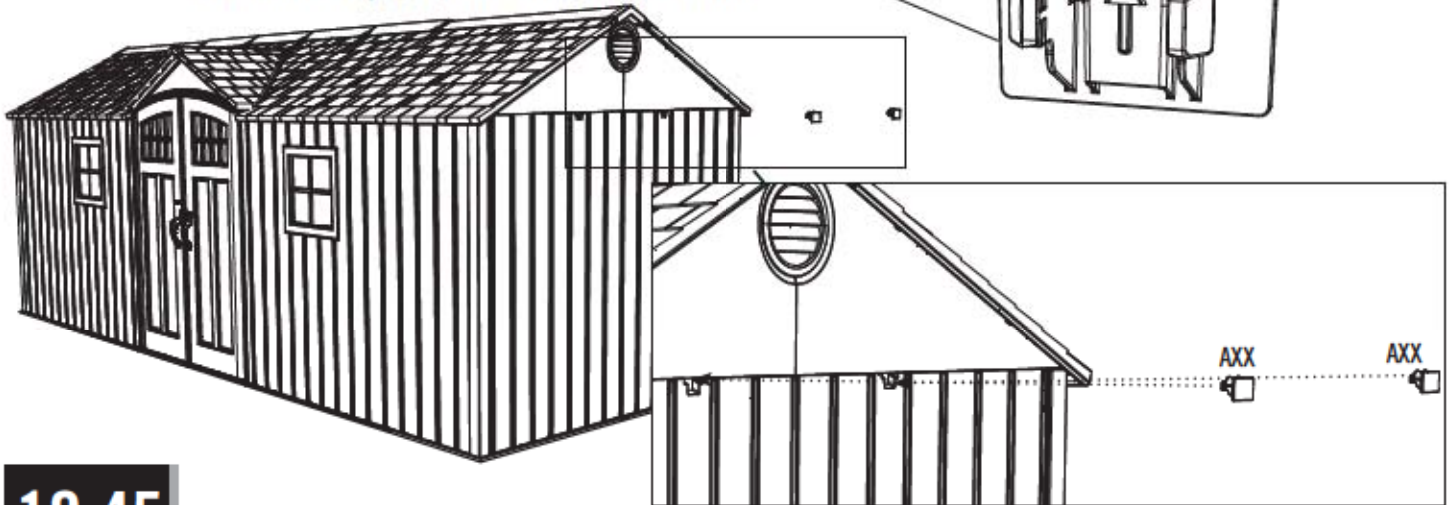

10.45

- Attach the **Left (AIC)** and **Right (AIM)** Gap Flaps to the corners of the Doors (**The Doors from steps 10.2 – 10.3**) using the hardware included. **These Flaps simply serve to block out light.**
- Attacher les **rabats gauche (AIC)** et **droit (AIM)** aux portes (**Les portes des étapes 10.2 – 10.3**) à l'aide de la quincaillerie incluse. **Ces rabats ne servent que pour empêcher la lumière d'entrer.**
- Sujetar las **tapas de las puertas izquierda (AIC)** y **derecha (AIM)** a las puertas (**Las puertas de los pasos 10.2 – 10.3**) usando el herraje incluido. **Estas tapas sirven sólo para tapar la luz.**

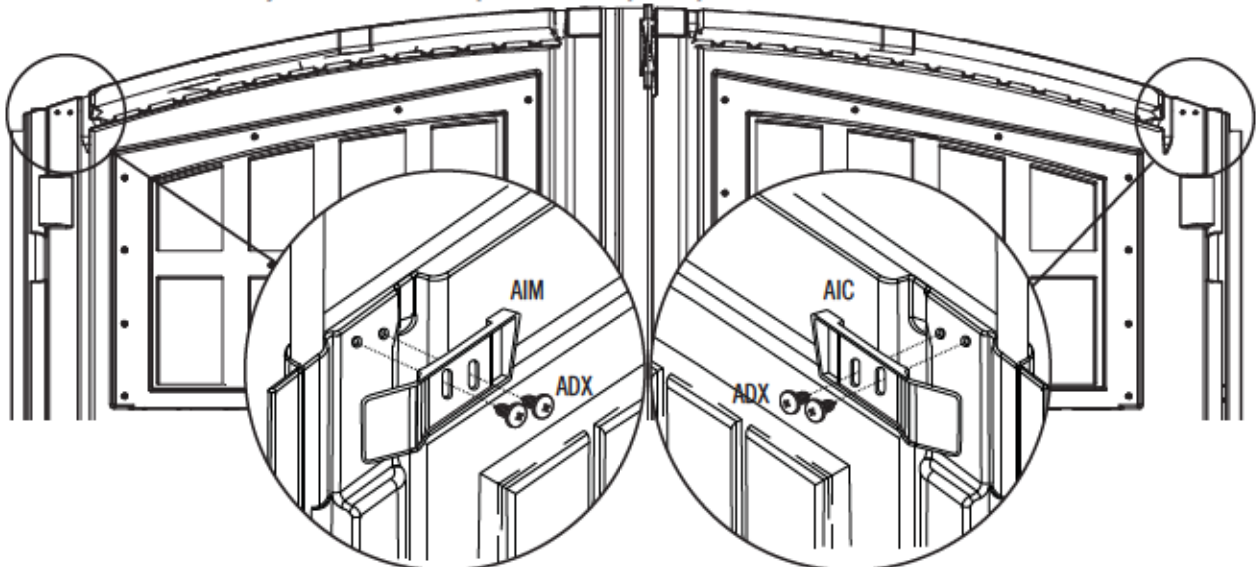



HARDWARE REQUIRED / QUINCAILLERIE REQUISE / HERRAJE REQUERIDO

Hardware Bags / Sacs de quincaillerie / Bolsas de herraje

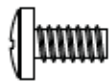

ADZ (x8)



ADY (x2)

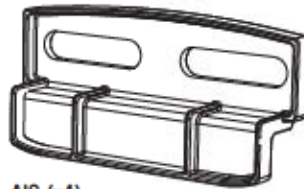

AIS (x4)

PARTS REQUIRED / PIÈCES REQUISES / PIEZAS REQUERIDAS

Plastic Parts / Pièces en plastique / Piezas de plástico



AHE (x2)



TOOLS REQUIRED / OUTILS REQUIS / INSTRUMENTAL REQUERIDO

► SECTION 11 (CONTINUED) / SECTION 11 (SUITE) / SECCIÓN 11 (CONTINUACIÓN)

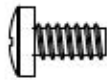
TOOLS AND PARTS REQUIRED / OUTILS ET QUINCAILLERIE REQUIS / INSTRUMENTAL Y HERRAJE REQUERIDOS

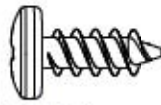

ADY (x2)



ADZ (x8)

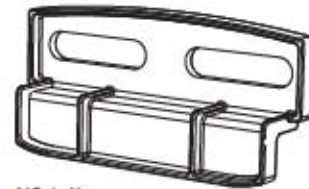

AIS (x4)



- If you have trouble with this section, follow the code below to view a how-to video on this section.
- En cas de problèmes avec cette section, suivre le code en bas pour voir un vidéo sur l'assemblage dans cette section.
- En caso de algun problema con esta sección, seguir el código debajo para ver un video sobre el ensamble en esta sección.



<http://go.lifetime.com/8wininstall>

11.1

- Peel off the protective plastic from both sides of the **Window Pane (AHE)**. With the curved edge at the top and facing toward you, slide the Window Pane down into the opening.
- Enlever la pellicule protectrice des deux côtés du **carreau (AHE)**. Avec le bord courbé vers le haut et faisant face de vous, faire glisser le carreau en place.
- Retirar la película protectora de las dos caras de la **hoja de ventana (AHE)**. Con el borde curvado hacia arriba y el interior, deslizar la hoja en su lugar.

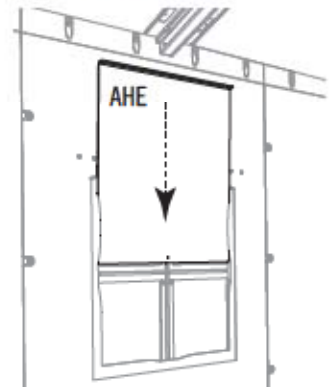

11.2

- Insert a **Screw (ADY)** into the hole at the bottom of the Window Pane. **This helps keep the Window Pane up when open.**
- Insérer une **vis (ADY)** dans le trou au bord inférieur du carreau. **Cela aide à maintenir en haut le carreau lorsqu'il est ouvert.**
- Insertar un **tornillo (ADY)** en el agujero al borde inferior de la hoja. **Esto ayuda a prevenir la cierre de la Hoja.**

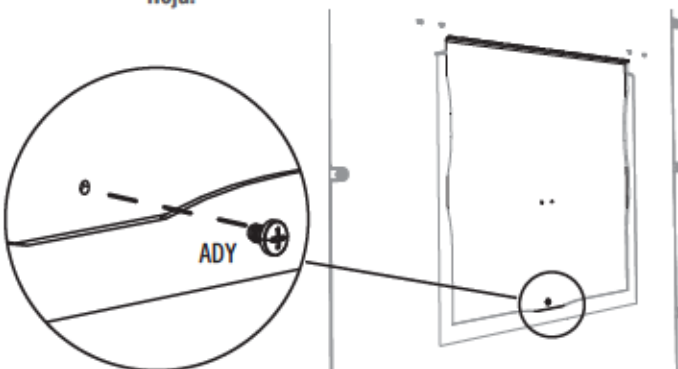

11.3

- Secure the two (2) **Window Latches (ADY)** at the top corners of the Panel opening. **The Latch should move freely. Repeat steps 11.1–11.3 for the second Window Pane.**
- Fixer les deux (2) **loquets (ADY)** aux angles supérieurs de l'ouverture du panneau. **Le loquet doit se déplacer librement. Répéter les étapes 11.1 – 11.3 pour le deuxième carreau.**
- Fijar los dos (2) **cerrojos (ADY)** a las esquinas superiores de la abertura del panel. **El cerrojo debe mover libremente. Repetir los pasos 11.1–11.3 para la segunda hoja de ventana.**



12

SHUTTER INSTALLATION / INSTALLATION DES VOIETS / INSTALACIÓN DE LAS CONTRAVENTANAS



HARDWARE REQUIRED / QUINCAILLERIE REQUISE / HERRAJE REQUERIDO

Hardware Bags / Sacs de quincaillerie / Bolsas de herraje



ARV (x16)



PARTS REQUIRED / PIÈCES REQUISES / PIEZAS REQUERIDAS

Plastic Parts / Pièces en plastique / Piezas de plástico

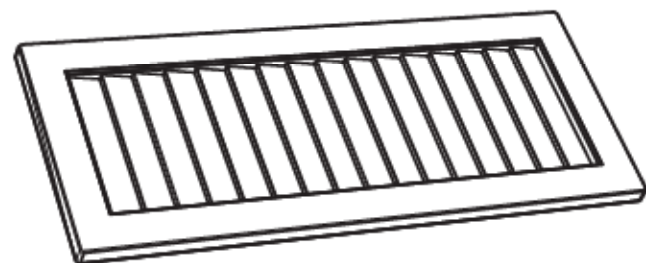

AYI (x4)



TOOLS REQUIRED / OUTILS REQUIS / INSTRUMENTAL REQUERIDO



► SECTION 12 (CONTINUED) / SECTION 12 (SUITE) / SECCIÓN 12 (CONTINUACIÓN)

TOOLS AND PARTS REQUIRED / OUTILS ET PIÈCES REQUIS / INSTRUMENTAL Y HERRAJE REQUERIDOS

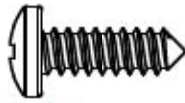

ARV (x1)

12.1

- There are four sets of two screw-location indicators. One by one, insert the **Screws (ARV)** through the indicators from the inside of the shed outward, and attach the **Shutters (AYI)** to the outside of the Wall Panels. **See step 12.2.**
- Il y a quatre groupes de deux indicateurs pour l'emplacement des vis. Une par une, insérer les **vis (ARV)** à travers les indicateurs de l'intérieur à l'extérieur, et attacher les **volets (AYI)** à l'extérieur des panneaux muraux. **Voir l'étape 12.2.**
- Hay cuatro juegos de dos indicadores para las ubicaciones de los tornillos. Uno por uno, insertar los **tornillos (ARV)** por los indicadores del interior al exterior, y sujetar las **contraventanas (AYI)** al exterior de los paneles murales. **Ver el paso 12.2.**

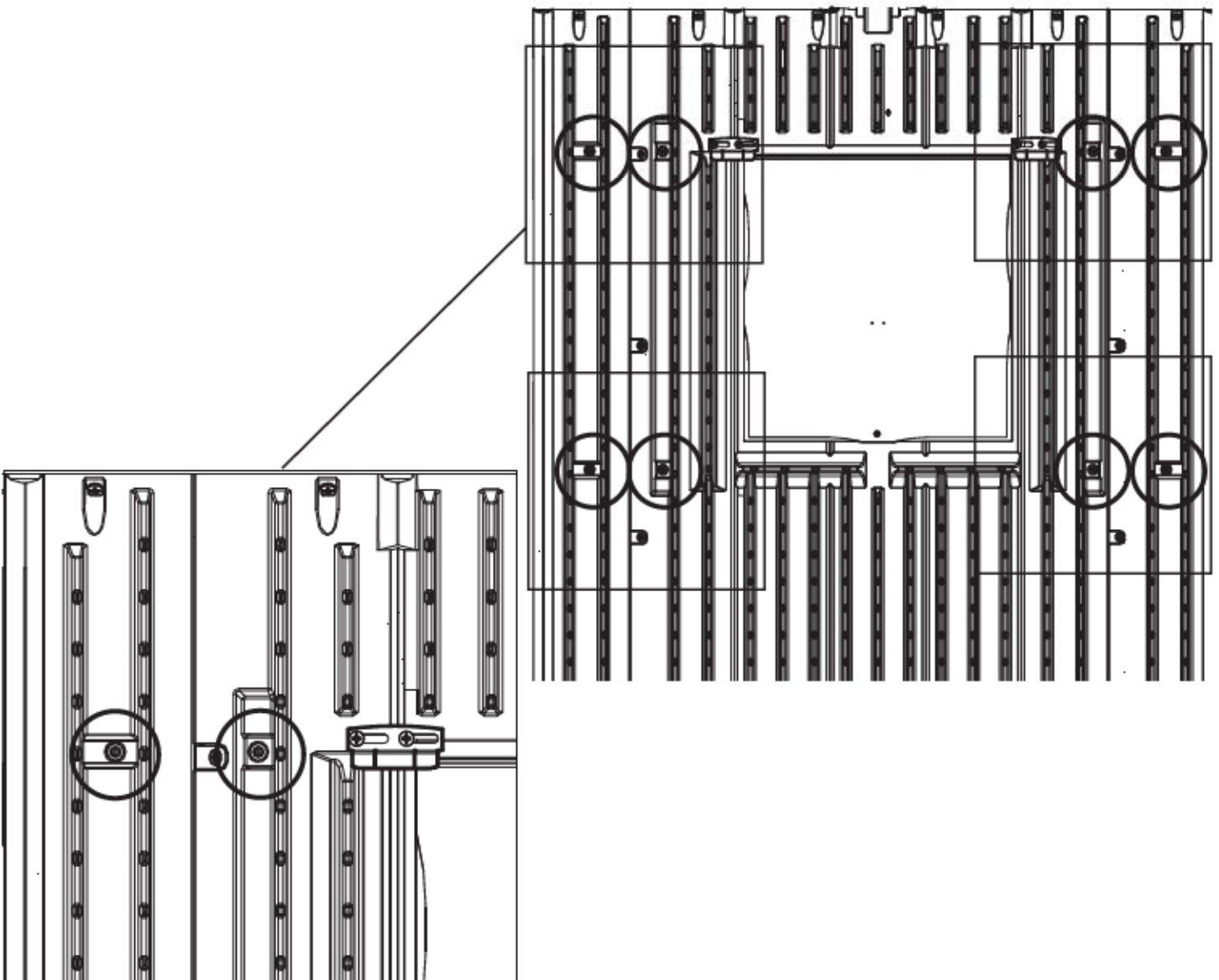

► SECTION 12 (CONTINUED) / SECTION 12 (SUITE) / SECCIÓN 12 (CONTINUACIÓN)

TOOLS AND PARTS REQUIRED / OUTILS ET PIÈCES REQUIS / INSTRUMENTAL Y HERRAJE REQUERIDOS

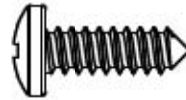

ARV (x7)

12.2

- Align the screw bosses in the **Shutters (AYI)** with the **Screws (ARV)** as you insert the Screws. Secure both Shutters to the Panels. **Repeat this section for the second Window.**
- Aligner les bossages de montage dans les **volets (AYI)** avec les **vis (ARV)** en insérant les vis. Fixer les deux volets aux panneaux. **Répéter cette section pour la deuxième fenêtre.**
- Alinear los huecos de montaje en las **contraventanas (AYI)** con los **tornillos (ARV)** al insertar los tornillos. Fijar ambas contraventanas a los paneles. **Repitir esta sección para la segunda ventana.**

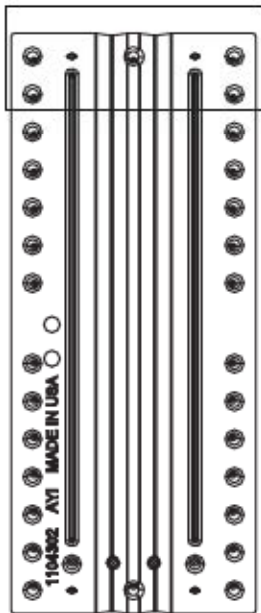

AYI

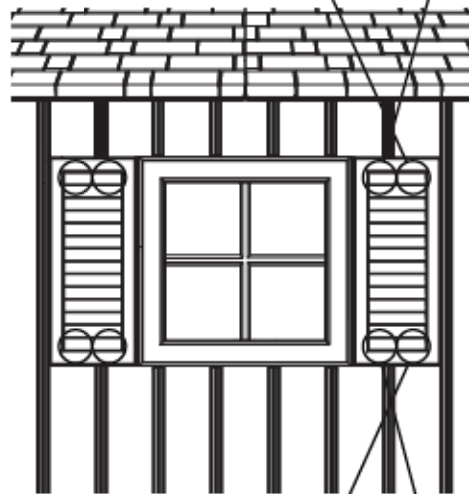
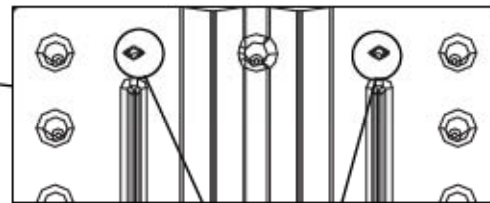

13

ACCESSORY INSTALLATION / INSTALLATION DES ACCESSOIRES / INSTALACIÓN DES ACCESORIOS



HARDWARE REQUIRED / QUINCAILLERIE REQUISE / HERRAJE REQUERIDO

Hardware Bags / Sacs de quincaillerie / Bolsas de herraje



ADZ (x14)

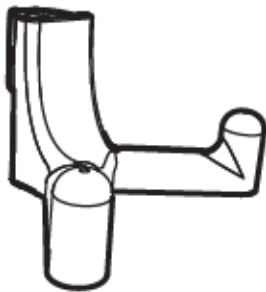

EDL (x18)



PARTS REQUIRED / PIÈCES REQUISES / PIEZAS REQUERIDAS

Large Part / Grande pièce / Pieza grande

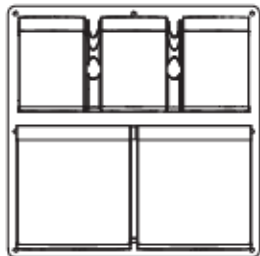

EDI (x2)



TOOLS REQUIRED / OUTILS REQUIS / INSTRUMENTAL REQUERIDO



► SECTION 13 (CONTINUED) / SECTION 13 (SUITE) / SECCIÓN 13 (CONTINUACIÓN)

TOOLS AND PARTS REQUIRED / OUTILS ET QUINCAILLERIE REQUIS / INSTRUMENTAL Y HERRAJE REQUERIDOS

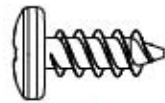

ADZ (x14)



EDL (x18)



• If you have trouble with this section, follow the code below to view a how-to video on this section.

• S'il y a des problèmes avec cette section, suivre le code en bas pour voir un vidéo sur l'assemblage dans cette section.

• Si hay problemas con esta sección, seguir el código debajo para ver un video sobre el ensamble en esta sección.

13.1

• Secure the **Door Pouch (EDI)** to the back of the Right or Left Door using seven (7) **Screws (ADZ)**.

Repeat this step for the other set of Doors.

• Attacher le **sac à porte (EDI)** au côté arrière de la porte droite ou gauche à l'aide de sept (7) **vis (ADZ)**.

Répéter cette étape pour l'autre jeu de portes.

• Sujetar la **bolsa para la puerta (EDI)** a la cara trasera de la puerta derecha o izquierda usando siete (7) **tornillos (ADZ)**. Repetir este paso para el otro juego de puertas.

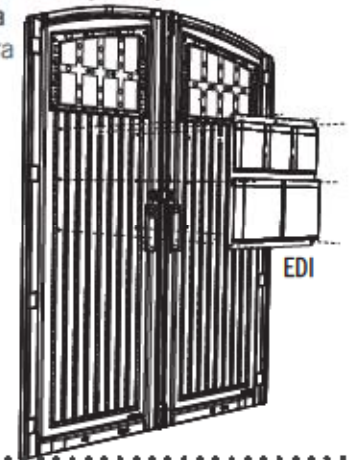

<http://go.lifetime.com/doorbaghooks>

13.2

• Insert the eighteen (18) **Wall Hooks (EDL)** into any of the notches in the Wall Panels (either side of the shed). Then push downward to lock them in place.

• Insérer les dix-huit (18) **crochets muraux (EDL)** dans les encoches dans les panneaux muraux (soit le côté droit, soit le côté gauche de l'abri). Ensuite, pousser-les vers le bas pour les attacher bien en place.

• Insertar los dieciocho (18) **ganchos murales (EDL)** en las muescas en los paneles murales (en cualquiera de los dos lados de la caseta). Entonces, empujarlos hacia abajo para fijarlos en su lugar.

WARNING
The total weight on a Wall Hook should not exceed 7 lb. (3.2 kg) nor more than 30 lb. (14 kg) on a Wall Panel. Failure to follow this warning could result in property damage and/or personal injury.

AVERTISSEMENT
Le poids total sur un crochet mural ne devrait pas excéder 7 lb (3,2 kg) ou plus de 30 lb (14 kg) sur un panneau mural. Le non-respect de cet avertissement peut entraîner des dommages à la propriété et/ou des blessures graves.



ADVERTENCIA
El peso total en un gancho mural no debe exceder de 7 lb. (3.2 kg) ni más de 30 lb. (14 kg) en un panel mural. El no seguir esta advertencia puede resultar en daños a la propiedad y/o en lesiones graves personales.

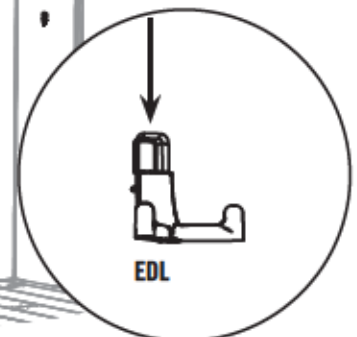

14

SNOWLOAD KIT INSTALLATION / INSTALLATION DU KIT LA CHARGE DE NEIGE / INSTALACIÓN DEL KIT DE LA CARGA DE NIEVE



HARDWARE REQUIRED / QUINCAILLERIE REQUISE / HERRAJE REQUERIDO

Hardware Bags / Sacs de quincaillerie / Bolsas de herraje

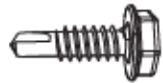

BRK (x200)



PARTS REQUIRED / PIÈCES REQUISES / PIEZAS REQUERIDAS

Metal Parts / Pièces en métal / Piezas de metal



EMA

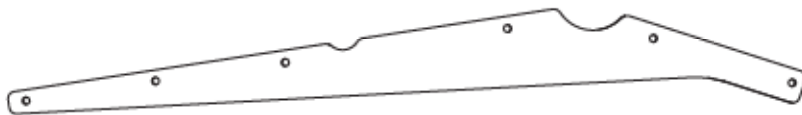

EGQ (x26)



ELZ



BRD (x7)

EGS (x1)

EGR (x1)



TOOLS REQUIRED / OUTILS REQUIS / INSTRUMENTAL REQUERIDO

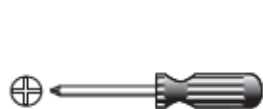

7/16 in/po (11 mm)



(2)



3/8 in/po (10 mm)



► SECTION 14 (CONTINUED) / SECTION 14 (SUITE) / SECCIÓN 14 (CONTINUACIÓN)

TOOLS AND PARTS REQUIRED / OUTILS ET QUINCAILLERIE REQUIS / INSTRUMENTAL Y HERRAJE REQUERIDOS



BRK (x156)



• If you have trouble with this section, follow the code below to view a how-to video on this section.

• En cas de problèmes avec cette section, suivre le code en bas pour voir un vidéo sur l'assemblage dans cette section.

• En caso de algun problema con esta sección, seguir el código debajo para ver un video sobre el ensamble en esta sección.



<http://go.lifetime.com/sidesnowload>

14.1



• Set a **Gusset (BQW)** up against a Truss as shown. Using an electric Drill, insert four **Screws (BRK)**. Repeat this step for both sides and both ends of all Trusses except for the Center Truss. Attach Gussets to just the back end of the Center Truss.

• Mettez un **gousset (BQW)** contre la ferme comme illustré. En utilisant un perceuse électrique, insérez quatre vis (**BRK**). Répétez cette étape pour les deux côtés et les deux extrémités d'une ferme. Attachez les goussets seulement à l'extrémité arrière de la ferme centrale.

• Coloque una **placa de refuerzo (BQW)** contra una cercha como se muestra. Usando un taladro eléctrico, inserte cuatro tornillos (**BRK**). Repita este paso para los dos lados y los dos extremos de todas las cerchas excepto la cercha central. Sujete las placas de refuerzo sólo al extremo trasero de la cercha central.

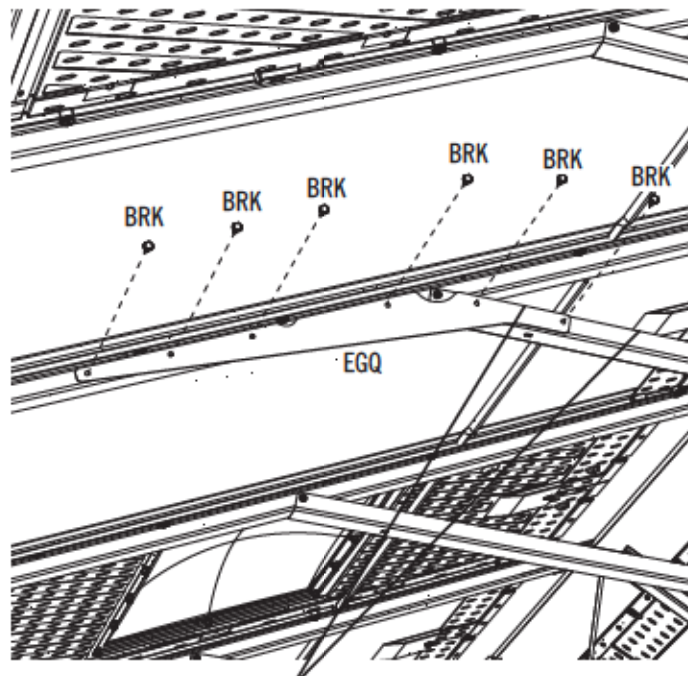

Note: Ensure the border of the Gusset is level and parallel with the Truss Brace.

Remarque : Assurez-vous que le bord du gousset est au même niveau et parallèle au support de ferme.

Nota: Asegúrese que el borde de la placa de refuerzo está alineado y que es paralela con el soporte del armazón.

► SECTION 14 (CONTINUED) / SECTION 14 (SUITE) / SECCIÓN 14 (CONTINUACIÓN)

TOOLS AND PARTS REQUIRED / OUTILS ET QUINCAILLERIE REQUIS / INSTRUMENTAL Y HERRAJE REQUERIDOS



7/16 in/po (x2)
11 mm (x2)



BRK (x28)

14.2

- Remove the Cap Nuts and the Threaded Rod from the Truss.
- Retirez les écrous à chape et la tige filetée de la Ferme.
- Retire las tuercas ciegas y la varilla roscada de la cercha.

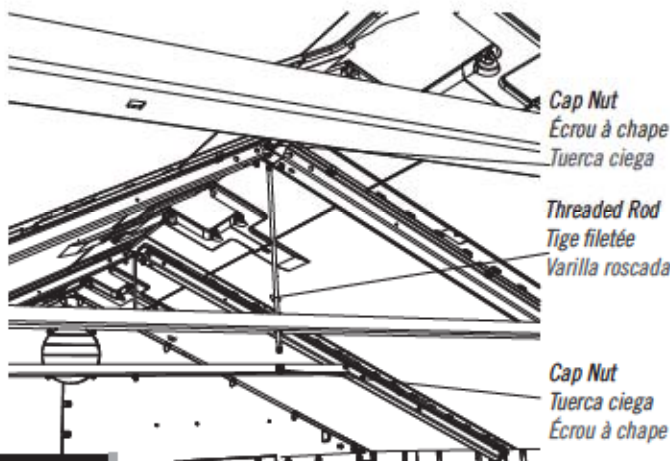

14.3

- Place a **Short Truss Brace (BRD)** up into a Truss, and re-insert the Threaded Rod through the Truss and Short Truss Brace as shown. **Hand tighten all Cap Nuts removed in the previous step.**
- Mettez le **support court (BRD)** à la ferme, et re-insérez le tige filetée à travers la ferme et le support court comme illustré. **Serrez à main les écrous à chape retirés dans l'étape précédente.**
- Coloque un **soporte corto (BRD)** al armazón, y reintroduzca la varilla roscada a través de la cercha y el soporte corto como se muestra. **Apriete a mano las Tuercas ciegas retiradas en el paso anterior.**

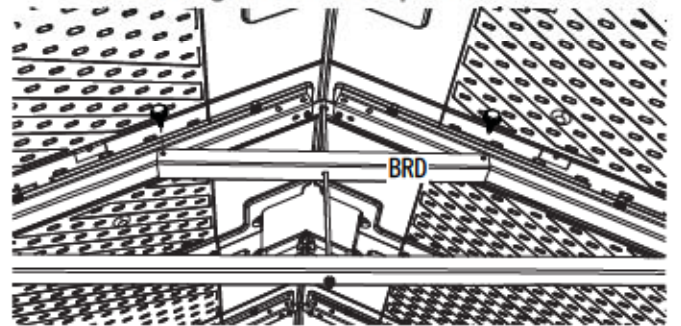

14.4



- Secure the Short Truss Brace to the Truss Assembly using four (4) **Self-Drilling/Self-Tapping Screws (BRK)**. **Tighten the Cap Nuts. Using other kits, repeat steps 14.2–14.5 for each Truss.**
- Attachez bien le support court à la ferme à l'aide de quatre (4) **vis autoperceuse/autotaraudeuse (BRK)**. **Serrez bien les écrous à chape. En employant des autres kits, répétez les étapes 14.2 – 14.5 pour chaque ferme.**
- Sujete el soporte corto a la cercha usando cuatro (4) **tornillos autoperforantes/autorroscantes (BRK)**. **Apriete bien las tuercas ciegas. Usando otros kits, repita los pasos 14.2–14.5 para cada cercha.**

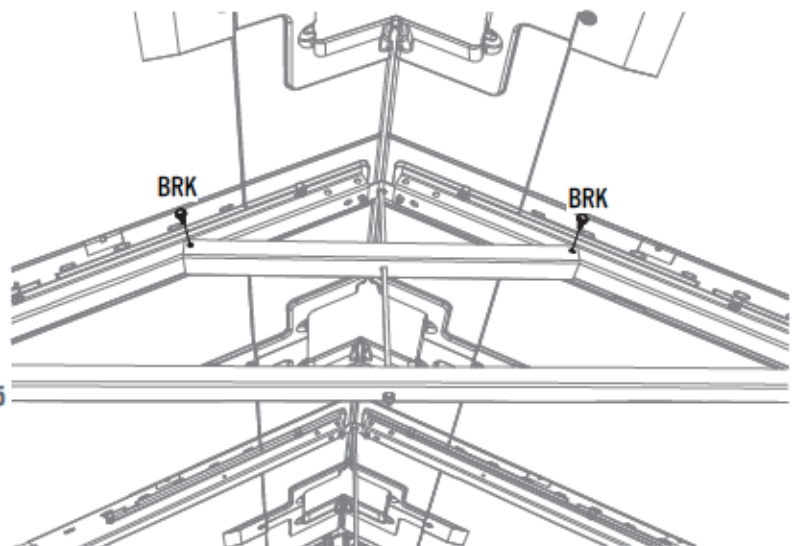

► SECTION 14 (CONTINUED) / SECTION 14 (SUITE) / SECCIÓN 14 (CONTINUACIÓN)

TOOLS AND PARTS REQUIRED / OUTILS ET QUINCAILLERIE REQUIS / INSTRUMENTAL Y HERRAJE REQUERIDOS



BRK (x8)

14.5

• Place the **Left Gable Support (EGR)** up flush against the Gable and Roof as shown. Secure with two (2) **Self-Tapping Screws (BRK)** to the Center Truss.



• Placez le **support gauche du pignon (EGR)** de sorte qu'il soit au ras du pignon d'entrée et le toit comme illustré.

Attachez-le à l'aide de deux (2) **vis autotaraudeuses (BRK)** à la ferme centrale.

• Coloque el **soporte izquierdo de la fachada (EGR)** para que quede a ras de la fachada de entrada y el tejado como se muestra. Sujételo con dos (2) **tornillos autoroscantes (BRK)** a la cercha central.

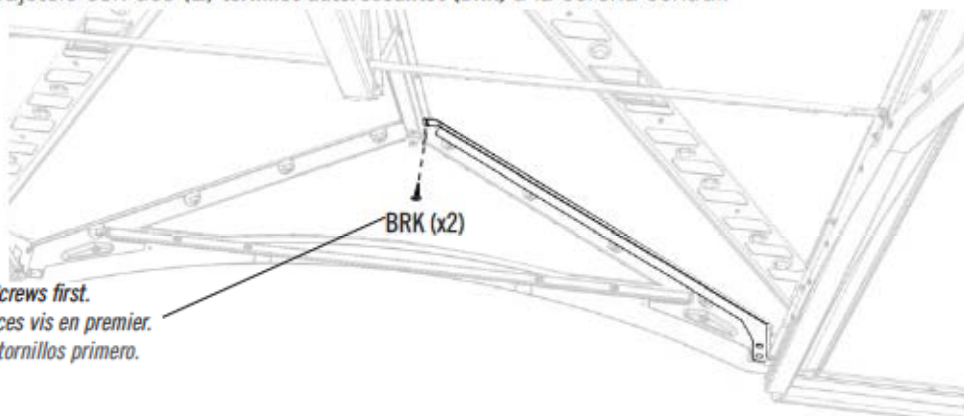

Note: Insert these Screws first.

Remarque: Insérez ces vis en premier.

Nota: Inserte estos tornillos primero.

14.6

• Insert two (2) **Self-Tapping Screws (BRK)** through the Gable and into the Door Hinge Tube. **The holes are oval shaped in case it's easier to insert the Screws into the Hinge Tube at an angle. The Door Hinge Tube is inside each Door and goes up into the Gable. Repeat steps 14.6–14.7 for the Right Gable Support (AGS).**

• Insérez deux (2) **vis autotaraudeuses (BRK)** à travers le pignon et dans le tube de charnière à porte. **Les trous sont de forme ovale s'il est plus facile insérer les vis dans le tube de charnière à un angle. Le tube de charnière à porte se trouve dans chaque porte et va dans le pignon. Répétez les étapes 14.6 – 14.7 pour le support droit du pignon (AGS).**

• Inserte dos (2) **tornillos autoroscantes (BRK)** por la fachada de entrada y dentro del tubo de bisagra para la puerta. **Los agujeros son de forma ovalada por si es más fácil insertar los tornillos dentro del tubo de bisagra a un ángulo. Se encuentra el tubo de bisagra para la puerta dentro de cada puerta, y va dentro de la fachada. Repita los pasos 14.6–14.7 para el soporte derecho de la fachada (AGS).**

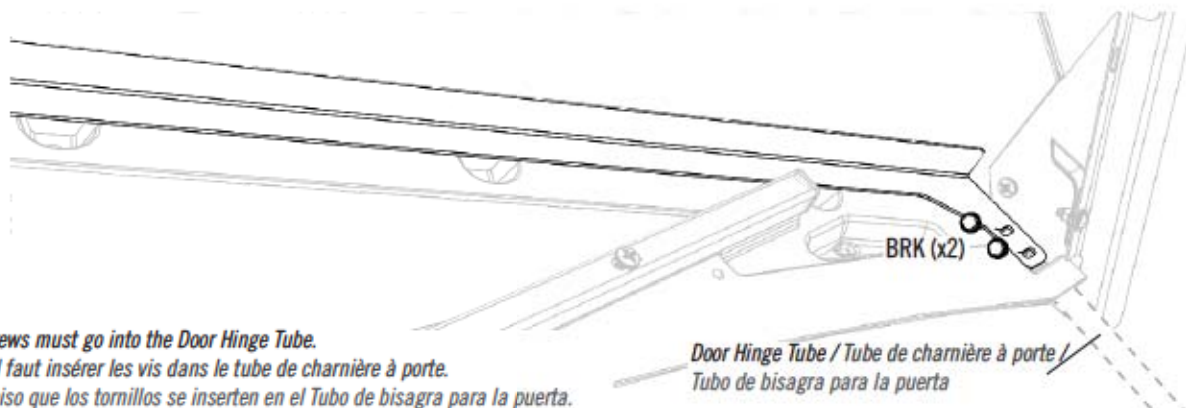

Note: The Screws must go into the Door Hinge Tube.

Remarque: Il faut insérer les vis dans le tube de charnière à porte.

Nota: Es preciso que los tornillos se inserten en el Tubo de bisagra para la puerta.

*Door Hinge Tube / Tube de charnière à porte /
Tubo de bisagra para la puerta*

15

DOOR ALIGNMENT / ALIGNEMENT DES PORTES / ALINEACIÓN DE LAS PUERTAS



HARDWARE REQUIRED / QUINCAILLERIE REQUISE / HERRAJE REQUERIDO

*NO HARDWARE INCLUDED FOR THIS SECTION
AUCUNE QUINCAILLERIE INCLUSE POUR CETTE SECTION
NINGÚN HERRAJE INCLUIDO PARA ESTA SECCIÓN*



PARTS REQUIRED / PIÈCES REQUISES / PIEZAS REQUERIDAS

Wood Parts / Pièces en bois / Piezas de madera



AIX (x4)



TOOLS REQUIRED / OUTILS REQUIS / INSTRUMENTAL REQUERIDO



▶ SECTION 15 (CONTINUED) / SECTION 15 (SUITE) / SECCIÓN 15 (CONTINUACIÓN)

TOOLS AND PARTS REQUIRED / OUTILS ET QUINCAILLERIE REQUIS / INSTRUMENTAL Y HERRAJE REQUERIDOS



- If you have trouble with this section, follow the code below to view a how-to video on this section.
- En cas de problèmes avec cette section, suivre le code en bas pour voir un vidéo sur l'assemblage dans cette section.
- En caso de algun problema con esta sección, seguir el código debajo para ver un video sobre el ensamble en esta sección.

15.1

- If the Doors are not even at the top, follow the steps on this page to align them.
- Si les portes ne sont pas alignées l'une avec l'autre à la partie supérieure, suivez les étapes dans cette page pour les aligner.
- Si las puertas no están alineadas a la parte superior, siga los pasos en esta página para alinearlas.



<http://go.lifetime.com/8alignment>



15.2

- If the Right Door scrapes the Floor or is lower than the Left Door, insert a **Shim (AIX)** under the Floor directly under the bottom corner of the Right Door. If necessary, repeat for the Left Door until both Doors are level and do not scrape. **Break off any excess Shim.**
- Si la porte droite frotte en se ferment ou est plus bas que la porte gauche, insérez une **cale (AIX)** sous le plancher directement sous le coin droit inférieur de la porte droite. S'il est nécessaire, répétez cette étape pour la porte gauche jusqu'à ce que les deux portes soient nivelées et ne frottent pas. **Détachez de l'excès des cales.**
- Si la puerta derecha se roza con el piso o es más bajo que la izquierda, inserte una **cuña (AIX)** debajo el piso directamente debajo la esquina inferior derecha de la puerta derecha. Si es necesario, repita este paso para la puerta izquierda o hasta que las dos puertas estén niveladas y no se rocen. **Quebrante cualquier exceso de las cuñas.**

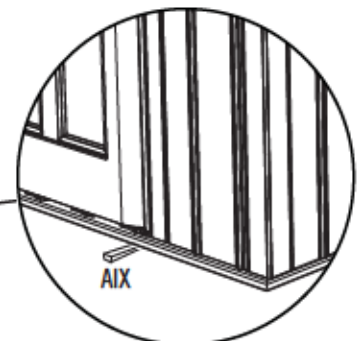
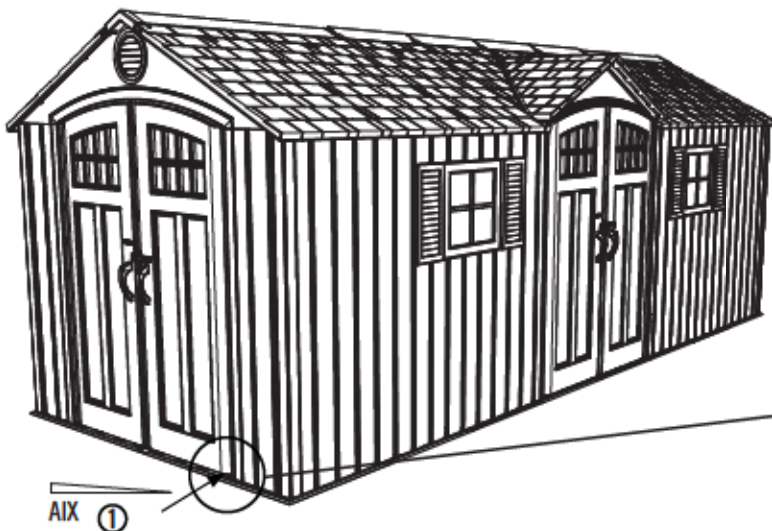



HARDWARE REQUIRED / QUINCAILLERIE REQUISE / HERRAJE REQUERIDO

*NO HARDWARE INCLUDED FOR THIS SECTION
AUCUNE QUINCAILLERIE INCLUSE POUR CETTE SECTION
NINGÚN HERRAJE INCLUIDO PARA ESTA SECCIÓN*



PARTS REQUIRED / PIÈCES REQUISES / PIEZAS REQUERIDAS

*NO PARTS REQUIRED FOR THIS SECTION
AUCUNE PIÈCE REQUISE POUR CETTE SECTION
NINGUNA PIEZA REQUERIDA PARA ESTA SECCIÓN*



TOOLS REQUIRED / OUTILS REQUIS / INSTRUMENTAL REQUERIDO

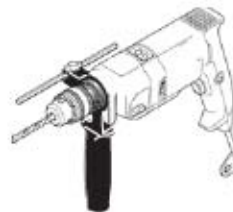

5/16" (8 mm) Wood Drill Bit
Foret à bois de 8 mm
Broca para madera de 8 mm



5/16" (8 mm) Masonry Drill Bit
Foret à maçonnerie de 8 mm
Broca para albañilería de 8 mm

► SECTION 16 (CONTINUED) / SECTION 16 (SUITE) / SECCIÓN 16 (CONTINUACIÓN)

FOR CONCRETE PLATFORMS / POUR LES PLATE-FORMES EN BÉTON / PARA PLATAFORMAS DE CONCRETO



16.1



- To anchor your shed, you must purchase the correct anchoring hardware. **For a concrete platform**, we recommend using a hammer drill, 5/16" (8 mm) masonry bit, sixteen (16) 3/8" x 2" (10 mm x 5 cm) Concrete Screws and sixteen (16) 3/8" x 1" (10 mm x 2,5 cm) Fender Washers. **Do not exceed a 3/8" (10 mm) diameter screw. Refer to your local hardware store for this hardware.**
- Pour ancrer l'abri, il faut acheter la quincaillerie d'ancrage correcte. **Pour une plate-forme en béton**, nous recommandons que vous utilisiez une perceuse de percussion, un foret à maçonnerie de 8 mm, seize (16) vis d'ancrage à béton de 10 mm x 5 cm (3/8 po x 2 po) et seize (16) rondelles de protection de 10 mm x 2,5 cm (3/8 po x 1 po). **Ne dépassez pas un diamètre de 10 mm (3/8 po). Votre quincaillerie du coin aura ces accessoires.**
- Para anclar la caseta, es necesario comprar el herraje de anclaje correcto. **Para una plataforma de concreto**, recomendamos que use un martillo perforador, broca de albañilería de 8 mm, dieciséis (16) tornillos de anclaje para concreto de 10 mm x 5 cm (3/8 in x 2 in) y dieciséis (16) rondanas de protección de 10 mm x 2,5 cm (3/8 in x 1 in). **No exceda un diámetro de 10 mm (3/8 in). Refiérase a su ferretería local para obtener este herraje.**

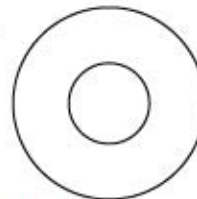
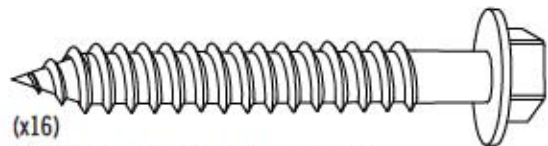
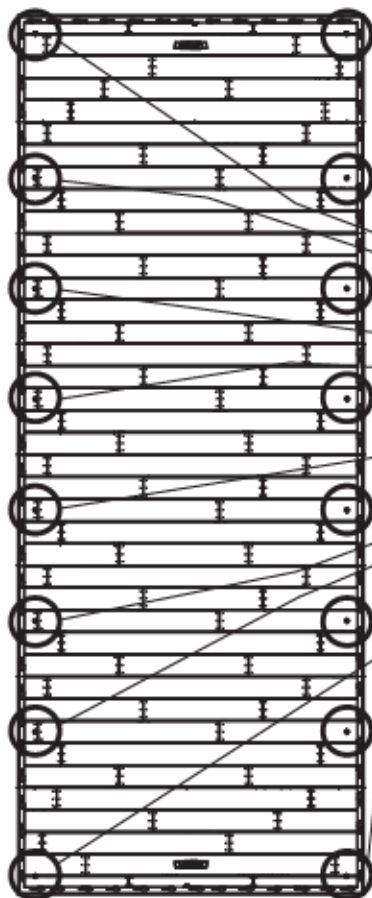

⚠ WARNING / AVERTISSEMENT / ADVERTENCIA ⚠

- Failure to anchor the shed may result in property damage and/or personal injury.
- Si vous n'ancrez pas votre abri, des dommages à la propriété et/ou des blessures peuvent en résulter.
- No anclar la caseta puede resultar en daños a la propiedad y/o en lesiones personales.

▶ SECTION 16 (CONTINUED) / SECTION 16 (SUITE) / SECCIÓN 16 (CONTINUACIÓN)

FOR WOOD PLATFORMS / POUR LES PLATE-FORMES EN BOIS / PARA PLATAFORMAS DE MADERA



5/16" (8 mm)



16.1



• To anchor your shed, you must purchase the correct anchoring hardware. **For a wood-framed platform**, we recommend using a drill, 5/16" (8 mm) drill bit, sixteen (16) 3/8" x 1 1/2" (10 mm x 4 cm) Lag Screws and sixteen (16) 3/8" x 1" (10 mm x 2,5 cm) Fender Washers. **Do not exceed a 3/8" (10 mm) diameter screw. Refer to your local hardware store for this hardware.**

• Pour ancrer l'abri, il faut acheter la quincaillerie d'ancrage correcte. **Pour une plate-forme en bois**, nous recommandons que vous utilisiez une perceuse électrique, un foret de 8 mm, seize (16) vis de retard de 10 mm x 4 cm (3/8 po x 1 1/2 po), et seize (16) rondelles de protection de 10 mm x 2,5 cm (3/8 po x 1 po). **Ne dépassez pas un diamètre de 10 mm (3/8 po). Votre quincaillerie du coin aura ces accessoires.**

• Para anclar la caseta, es necesario comprar el herraje de anclaje correcto. **Para una plataforma hecho de hecho de madera**, recomendamos que use un taladro eléctrico, una broca de 8 mm, dieciséis (16) tornillos para madera de 10 mm x 4 cm (3/8 in x 1 1/2 in) y dieciséis (16) rondanas de protección de 10 mm x 2,5 cm (3/8 in x 1 in). **No exceda un diámetro de 10 mm (3/8 in). Refiérase a su ferretería local para obtener este herraje.**

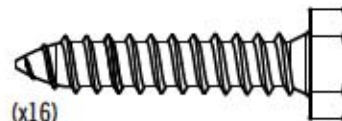
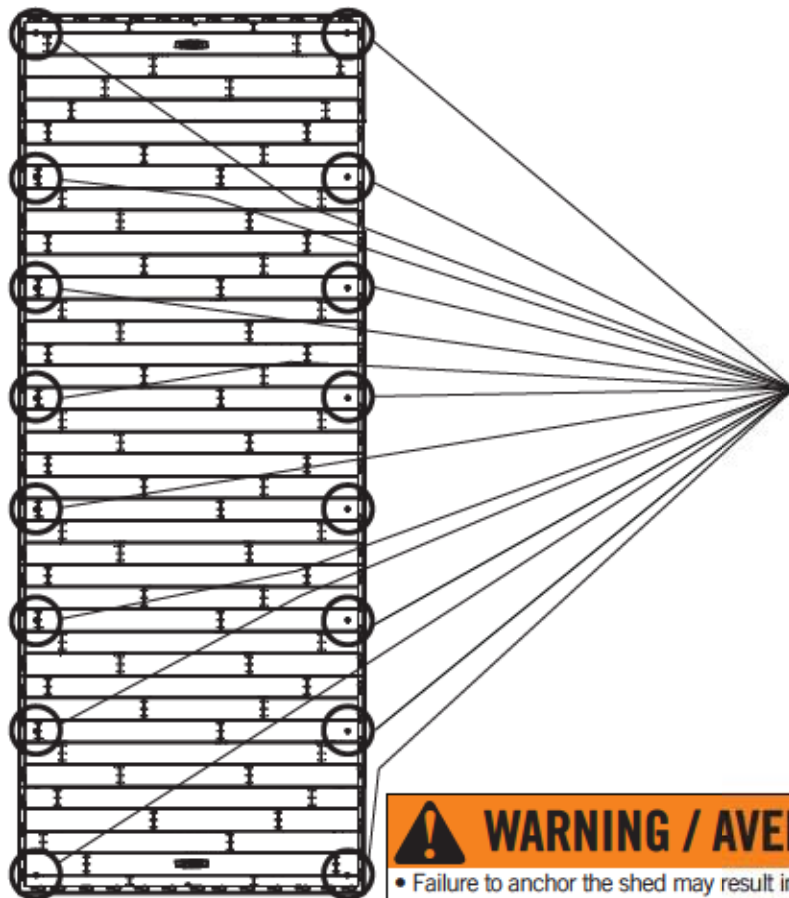

(x16)

(Not included) (Pas incluses) (No incluidos)

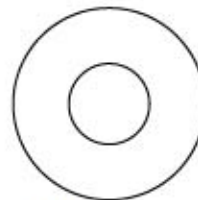

(x16)

(Not included) (Pas incluses) (No incluidas)

⚠ WARNING / AVERTISSEMENT / ADVERTENCIA ⚠

- Failure to anchor the shed may result in property damage and/or personal injury.
- Si vous n'ancrez pas votre abri, des dommages à la propriété et/ou des blessures peuvent en résulter.
- No anclar la caseta puede resultar en daños a la propiedad y/o en lesiones personales.



CLEANING & CARE

Congratulations on your Lifetime® product purchase. By following the instructions below, your new Lifetime product should provide you with years of service and enjoyment.

The polyethylene panels are stain and solvent resistant. Most stains can be removed using a mild soap and a soft-bristled brush. Abrasive cleaning materials may scratch the plastic and are not recommended. Repair scratches or rust spots on the metal by sanding the affected area lightly; using a rust preventative spray primer; and finally, spraying with a high-gloss spray enamel paint. Avoid placing a direct heat source on or near surfaces unless using a heat barrier.



NETTOYAGE ET ENTRETIEN

Nous vous félicitons d'avoir acheté ce produit Lifetime®. En suivant les instructions ci-dessous, votre nouveau produit Lifetime devrait vous fournir des années de service et de plaisir.

Les murs et les étagères en polyéthylène sont résistants aux taches et solvants de nettoyage. Pour les nettoyer, servez-vous d'un savon doux et d'une brosse douce. Les produits abrasifs de nettoyage risquent d'égratigner le plastique et ne sont pas recommandés. Pour réparer les égratignures ou taches de rouille sur le métal, frottez légèrement l'endroit affecté au papier de verre, puis passez un couche de produit vaporisant préventif et enfin vaporisez une peinture émail ultrabrillante. Évitez de placer une source de chaleur directe sur ou près des surfaces, ou protégez-les à l'aide d'une protection contre la chaleur.



LIMPIEZA Y CUIDADO

Felicidades por la compra de su producto Lifetime®. Al seguir las siguientes instrucciones, su nuevo producto Lifetime le brindará años de servicio y satisfacción.

Los paneles de polietileno son resistentes a las manchas y solventes. La mayoría de las manchas puede removerse usando un jabón suave y un cepillo de cerdas suaves. Los materiales abrasivos para limpieza pueden rayar el plástico y no se recomiendan. Repare rayones o manchas de óxido en el metal, lijando suavemente la parte afectada; usando un aerosol preventivo de óxido y finalmente, rociando con una pintura de esmalte brillante. Evite poner una fuente de calor directa en o cerca de las superficies a menos que utilice una barrera de calor.



REGISTER YOUR PRODUCT ONLINE AT WWW.LIFETIME.COM

At Lifetime®, we are committed to providing innovative and quality products. While registering, you will have the opportunity to give us your feedback. Your input is valuable to us.

- You can also opt in to receive new product notifications or promotions.
- In the unlikely event of a product recall or safety modification, your registration provides the information we need to notify you directly.
- Registration is fast, easy, and completely voluntary.

LIFETIME'S PROMISE TO YOU:

Maintaining your privacy is our long-standing policy at Lifetime®. And you can rest assured that Lifetime® will not sell or provide your personal data to other third parties, or allow them to use your personal data for their own purposes.

We invite you to read our privacy policy at www.lifetime.com

REGISTER today!



ENREGISTRER CE PRODUIT EN LIGNE À WWW.LIFETIME.COM

Chez Lifetime®, nous nous engageons à fournir des produits innovateurs de qualité. Lors de votre inscription, vous aurez l'occasion de nous faire parvenir vos commentaires. Votre opinion est importante pour nous.

- On peut également choisir de recevoir des avis ou des promotions dans le cadre de nouveaux produits.
- Dans l'éventualité improbable d'un rappel ou d'un avis de sécurité, l'inscription fournit les renseignements nécessaires nous permettant de communiquer avec vous.
- L'inscription est rapide, facile et complètement volontaire.

LA PROMESSE DE LIFETIME :

Conserver votre confidentialité est notre politique de longue date chez Lifetime®. Vous pouvez donc être rassuré par le fait que Lifetime® ne vendra pas ou ne fournira pas vos données personnelles à des tiers, et ne leur permettra pas d'utiliser vos données personnelles à leurs propres fins.

Nous vous invitons à lire notre politique de confidentialité à www.lifetime.com

ENREGISTRER CE PRODUIT aujourd'hui!



REGISTRAR EL PRODUCTO EN LÍNEA EN WWW.LIFETIME.COM

En Lifetime®, estamos comprometidos a ofrecer productos innovadores y de calidad. Al registrarse, usted tendrá la oportunidad de darnos su retroalimentación. Su información es valiosa para nosotros.

- También puede optar por recibir nuestras notificaciones o promociones.
- En el caso improbable de que el producto tenga que salir del mercado o que sufra alguna modificación, su registro provee la información que necesitamos para notificarle directamente.
- El registro es rápido, fácil y completamente voluntario.

LA PROMESA DE LIFETIME® PARA USTED:

Mantener privacidad es nuestra política permanente en Lifetime®. Y puede estar seguro que Lifetime® no venderá ni dará datos personales a terceros, ni les permitirá usar datos personales para fines propios.

Lo invitamos a leer nuestra política de privacidad en www.lifetime.com

¡REGISTRARSE hoy mismo!



10-YEAR LIMITED FACTORY WARRANTY

THE MANUFACTURER RESERVES THE RIGHT TO MAKE SUBSTITUTIONS TO WARRANTY CLAIMS IF PARTS ARE UNAVAILABLE OR OBSOLETE.

1. Lifetime outdoor sheds are warranted to the original purchaser to be free from defects in material or workmanship for a period of ten years from the date of original retail purchase. The word "defects" is defined as imperfections that impair the use of the product. Defects resulting from misuse, abuse or negligence will void this warranty. This warranty does not cover defects due to improper installation, alteration or accident. This warranty does not cover damage caused by vandalism, rusting, "acts of nature" or any other event beyond the control of the manufacturer.
2. This warranty is nontransferable and is expressly limited to the repair or replacement of defective product. If the product is defective within the terms of this warranty, Lifetime Products, Inc. will repair or replace defective parts at no cost to the purchaser. Shipping charges to and from the factory or distribution center are not covered and are the responsibility of the purchaser. Labor charges and related expenses for removal, installation or replacement of the shed or its components are not covered under this warranty.
3. This warranty does not cover scratching or scuffing of the product that may result from normal usage. In addition, defects resulting from intentional damage, negligence, unreasonable use or hanging from the truss will void this warranty.
4. Liability for incidental or consequential damages is excluded to the extent permitted by law. While every attempt is made to embody the highest degree of safety in all equipment, freedom from injury cannot be guaranteed. The user assumes all risk of injury resulting from the use of this product. All merchandise is sold on this condition, and no representative of the company may waive or change this policy.
5. This product is not intended for institutional or commercial use; Lifetime Products, Inc. does not assume any liability for such use. Institutional or commercial use will void the warranty.
6. Our goods come with guarantees that cannot be excluded under the Australian Consumer Law. You are entitled to a replacement or refund for a major failure and for compensation for any other reasonably foreseeable loss or damage. You are also entitled to have the goods repaired or replaced if the goods fail to be of acceptable quality and the failure does not amount to a major failure.
7. This warranty is expressly in lieu of all other warranties, expressed or implied, including warranties of merchantability or fitness for use to extent permitted by Federal and state law. Neither Lifetime Products, Inc., nor any representative assumes any other liability in connection with this product. This warranty gives you specific legal rights, and you may also have other rights which vary from state to state (or province to province, as applicable in Canada).

PLEASE INCLUDE YOUR DATED SALES RECEIPT AND PHOTOGRAPHS OF DAMAGED PARTS.

REPORT PRODUCT DEFECTS IN WRITING TO:

Lifetime Products, Inc., PO Box 160010 Clearfield, UT 84016-0010

or call 1-800-225-3865 M-F 7 a.m. to 5 p.m. MST.

REGISTER YOUR PRODUCT FOR QUICKER CUSTOMER SERVICE.

Visit www.lifetime.com or call 1-800-225-3865 to register your product today.

FOR INTERNATIONAL WARRANTY CLAIMS:

All warranty claims must be accompanied by a sales receipt. Report all warranty claims in writing to your regional sales support representative. Please include your dated sales receipt and photographs of damaged parts.

To identify the representative for your region, please visit: www.lifetime.com/international



www.lifetime.com



GARANTIE DE FABRICATION LIMITÉE DE 10 ANS

LE FABRICANT RÉSERVE LE DROIT DE FAIRE DES SUBSTITUTIONS EN CAS DE RECOURS EN GARANTIE SI LES PIÈCES NE SONT PAS DISPONIBLES OU SONT OBSOLÈTES

1. Les abris extérieurs Lifetime[®] sont garantis à l'acheteur d'origine contre tous défauts de matériau ou de fabrication pendant une durée de dix ans à partir de la date d'achat d'origine. Le mot « défauts » signifie des défauts qui empêchent l'utilisation du produit. Les défauts résultant de mauvais usage, d'abus ou de négligence annulent cette garantie. Cette garantie ne couvre pas les dommages causés par le vandalisme, la rouille, « les calamités naturelles » ou tout autre événement en dehors du contrôle du fabricant.
2. Cette garantie n'est pas transférable et est expressément limitée à la réparation ou au remplacement du produit défectueux. Si le produit est déclaré défectueux selon les termes de cette garantie, Lifetime[®] Products, Inc. réparera ou remplacera les parties défectueuses gratuitement pour l'acheteur. Les frais d'expéditions aller et retour de l'usine ne sont pas couverts et sont à la charge de l'acheteur. Les frais de main-d'œuvre et frais associés à l'enlèvement, au montage ou au remplacement de l'abri ou de ses composantes ne sont pas couverts par cette garantie.
3. Cette garantie ne couvre pas les égratignures ou éraillures du produit résultant d'une utilisation normale. Par ailleurs, les défauts résultant de dommages intentionnels, négligence, utilisation abusive ou suspension à partir de l'entretoise annulent cette garantie.
4. Toute responsabilité pour dommages incidents ou consécutifs est exclue dans la mesure permise par la loi. Bien que toutes les mesures aient été prises pour intégrer le plus haut degré de sécurité dans l'ensemble du matériel, l'impossibilité de blessure ne peut pas être garantie. L'utilisateur assume tous les risques de blessure résultant de l'utilisation de ce produit. L'ensemble de la marchandise est vendu en vertu de cette condition et aucune personne représentant la société ne peut déroger à cette politique, ni la modifier.
5. Ce produit n'est pas prévu pour l'usage institutionnel ni commercial; Lifetime[®] Products, Inc. n'assume aucune responsabilité pour tel usage. L'utilisation institutionnelle ou commerciale annulera cette garantie.
6. Nos articles sont offerts avec des garanties qui ne peuvent connaître d'exclusions au regard de la loi australienne sur la protection des consommateurs. Vous avez droit au remplacement ou au remboursement en cas de défaillance majeure de votre article ainsi qu'à une compensation en cas de perte ou de dommage prévisible. Vous avez aussi droit à la réparation ou au remplacement de l'article s'il n'est pas d'une qualité acceptable et que la défaillance n'est pas majeure.
7. Cette garantie remplace expressément toutes autres garanties, expresse ou tacite, y compris les garanties de commercialisation ou d'adaptation à un but particulier dans la mesure permise par les lois fédérales et des états. Ni Lifetime[®] Products, Inc. ni aucun de ses représentants n'assume aucune autre responsabilité concernant ce produit. Cette garantie vous accorde des droits particuliers, et vous aurez peut-être d'autres droits qui varient d'un état à l'autre (ou d'une province à l'autre, selon le cas au Canada).

TOUS LES RECOURS EN GARANTIE DOIVENT ÊTRE ACCOMPAGNÉS DU REÇU DE VENTE.

FAIRE PARVENIR UN RAPPORT PAR ÉCRIT DE DÉFECTUOSITÉ DU PRODUIT A :

Lifetime Products, Inc., PO Box 160010 Clearfield, UT 84016-0010
ou composer 1.800.225.3865 lundi à vendredi 0700 - 1700 (HNR)

ENREGISTRER VOTRE ARTICLE À :

www.lifetime.com, ou composer 1.800.225.3865 pour enregistrer votre article aujourd'hui.

POUR RECOURS EN GARANTIE INTERNATIONAUX:

Tous les recours en garantie doivent être accompagnés du reçu de vente. Faire parvenir un rapport par écrit de défectuosité du produit au représentant régional de ventes. Veiller à inclure votre reçu de vente daté et photographies des pièces endommagées. Pour identifier le représentant régional, visiter www.lifetime.com/international



www.lifetime.com



GARANTÍA DE FÁBRICA LIMITADA POR 10 AÑOS

EL FABRICANTE SE RESERVA EL DERECHO DE HACER SUSTITUCIONES EN LOS ELEMENTOS REEMPLAZADOS BAJO GARANTÍA SI LAS PIEZAS NO ESTÁN DISPONIBLES O SON OBSOLETAS.

1. El comprador original recibe la garantía de que las casetas Lifetime estarán libres de defectos de material o de mano de obra por un período de 10 años a contar desde la fecha de la compra original. La palabra "defectos" se define como imperfecciones que perjudican el uso del producto. Los defectos emergentes de un mal uso, abuso o negligencia invalidarán esta garantía. Esta garantía no cubre defectos debidos a una instalación o alteración incorrecta o a un accidente. Esta garantía no cubre daños causados por vandalismo, oxidación, "actos de la naturaleza" u otros eventos que estén más allá del control del fabricante.
2. Esta garantía es intransferible, y queda expresamente limitada a la reparación o reemplazo de los productos defectuosos. Si el producto se encuentra defectuoso dentro de los términos de esta garantía, Lifetime Products, Inc. reparará o reemplazará las piezas defectuosas sin costo alguno para el comprador. Los gastos de envío hacia y desde la fábrica no están cubiertos, y quedan bajo la responsabilidad del comprador.
3. Esta garantía no cubre raspaduras ni marcas en el producto que pueden resultar de su uso normal. Además, los defectos causados por daños intencionales, negligencia, uso irrazonable o por colgarse de las cabriadas invalidarán esta garantía.
4. La responsabilidad por daños incidentales o consecuentes queda excluida hasta el punto en que lo permita la ley. Si bien se hace el mayor esfuerzo posible para lograr el más alto grado de seguridad en todos nuestros equipos, no puede garantizarse la libertad de cualquier tipo de lesión. El usuario asume todos los riesgos de lesiones emergentes del uso de este producto. Toda nuestra mercadería se vende bajo esta condición, y ningún representante de la compañía puede anular ni cambiar esta política.
5. Este producto no está pensado para el uso institucional ni comercial; Lifetime Products, Inc. no asume ninguna otra responsabilidad en conexión con este producto. El uso institucional o comercial invalidará la garantía.
6. Nuestros productos vienen con garantías que no se pueden excluir bajo la Ley del consumidor de Australia. Ustedes están autorizados para reemplazarlos u otorgar una devolución o reembolso en caso de falla mayor y en compensación por cualquier otra falla o daño previsible. También, están autorizados para hacer reparar los productos o reemplazarlos si éstos no cumplen con una calidad aceptable y si la falla no es motivo de una deficiencia mayor.
7. Esta garantía se otorga en reemplazo expreso de toda otra garantía, expresa o implícita, incluidas las garantías de comercialización o adaptación para el uso en la medida permitida por las leyes federales y estatales. Ni Lifetime Products, Inc., ni ninguno de sus representantes asume ninguna otra responsabilidad en conexión con este producto. Esta garantía le otorga derechos legales específicos, y usted puede tener otros derechos que varían de estado a estado (o de una provincia a otra, según corresponda en Canadá).

NINGUNA GARANTÍA OFRECIDA POR EL FABRICANTE ES VÁLIDA EN MÉXICO

TODOS LOS RECLAMOS DE GARANTÍA DEBEN ESTAR ACOMPAÑADOS POR UN RECIBO DE COMPRA

INFORME POR ESCRITO LOS DEFECTOS EN EL PRODUCTO A:

Por favor, incluir el recibo de compra fechado y fotografías de las piezas dañadas.

Lifetime Products, Inc., PO Box 160010 Clearfield, UT 84016-0010,

o marcar al 1.800.225.3865 de lunes a viernes de 0700 hasta 1700 (Hora de las Montañas)

REGISTRAR SU PRODUCTO

Visitar nuestra página en Internet www.lifetime.com, o marcar al 1.800.225.3865 para registrar el producto hoy.

PARA RECLAMOS DE GARANTÍA INTERNACIONALES:

Todos los reclamos de garantía deben estar acompañados por un recibo de compra. Informar por escrito todos los reclamos de garantía a su representante regional de ventas. Favor de incluir el recibo de compra fechado y fotografías de las piezas dañadas.

Para identificar el representante regional, visitar www.lifetime.com/international



www.lifetime.com

ENHANCE YOUR LIFETIME® PURCHASE BY ADDING ACCESSORIES OR OTHER GREAT PRODUCTS

To purchase accessories or other Lifetime® products, visit us at:

www.lifetime.com

Or call: 1-800-424-3865

7:00 am–5:00 pm (M–F) MST and 9:00 am–1:00 pm Saturday MST

AMÉLIORER VOTRE ACHAT LIFETIME® EN AJOUTANT DES ACCESSOIRES OU DES AUTRES PRODUITS

Pour acheter des accessoires ou des autres produits Lifetime®, rendre-nous visite à :

www.lifetime.com

Ou composer au 1-800-424-3865

Du lundi au vendredi 7 h – 17 h (HNR) et samedi 9 h – 13 h (HNR)

MEJORAR SU COMPRA LIFETIME® Y AÑADIR ACCESORIOS U OTROS PRODUCTOS EXCELENTES

Para comprar accesorios u otros productos Lifetime® EUA, visítenos en:

www.lifetime.com

O marcar al: 1.800.424.3865

De lunes hasta viernes 7:00 h–17:00 h (HNR) y sábado 9:00 h–13:00 h (HNR)



www.lifetime.com



Made in the U.S.A. / Fabriqué aux États-Unis / Hecho en los E.U.A.